



Qualität von Anfang an.

## Technische Daten

### BAUFORM

Druckgesteuertes Nadelventil mit aufgebautem Stellungsregler PG01.

### STEUERFUNKTIONEN

Stetige Regelung

### WERKSTOFFE

Gehäuse: Edelstahl 1.4408  
Innenteile: Edelstahl  
Steuerzylinder: Edelstahl 1.4408  
Dichtungen: FKM / EPDM

### ANSCHLUSS

Gewinde G 1/2"  
(DIN ISO 228 T1)

### STEUERANSCHLUß

G 1/8" (DIN ISO 228 T1)

### STEUERDRUCK

6 bar

### DURCHFLUSSMEDIUM

Gasförmige oder flüssige Medien

### VIKOSITÄT

400 mm<sup>2</sup>/s

### DURCHFLUSSVOLUMEN

siehe Bestellangaben

### NENNDRUCK

PN10, andere auf Anfrage

### MEDIUMTEMPERATUR

bis max. +150°C

### UMGEBUNGSTEMPERATUR

0°C bis +60°C

### STEUERMEDIUM

Luft oder neutrale Gas  
nach ISO 8573-1, Klasse 3, 3, 3

### EINBAULAGE

bevorzugt mit senkrecht stehendem Steuerzylinder.

### ELEKTROPNEUMATISCHER STELLUNGS- REGLER

Gehäusewerkstoff: Unterteil Aluminium  
Oberteil PP  
Anschlußspannung: 24 V DC (+10%/-5%)  
Eingangssignal: 4 - 20 mA  
Stellungsrückmeldung: 0 - 10 V  
Anschluss: Stecker M12 - A-kodiert  
Weitere Daten siehe Datenblatt: KAT-PG01.

## Specification

### DESIGN

Pressure actuated needle valve with electro-pneumatic positioner.

### OPERATION

Continuous control

### MATERIAL

Body: Stainless steel 1.4408  
Inner parts: Stainless steel  
Pilot cylinder: Stainless steel 1.4408  
Seals: FKM / EPDM

### CONNECTION

Female thread G 1/2"  
(DIN ISO 228 T1)

### PILOT PORT

G 1/8" (DIN 228 T1)

### PILOT PRESSURE

6 bar

### MEDIA

Liquids or gaseous media

### VISCOSITY

400 mm<sup>2</sup>/s

### FLOW VALUE

see table page 2

### NOMINAL PRESSURE

PN10, others on request

### TEMPERATURE RANGE

up to max. +150°C

### TEMPERATURE OF THE ENVIRONMENT

0°C up to +60°C

### PILOT MEDIA

Air or neutral gases  
acc. to ISO8573, Class 3, 3, 3

### INSTALLATION

Pilot cylinder preferably vertical on top.

### ELECTROPNEUMATIC POSITIONER

Housing material: body aluminium  
cover PP  
Power supply: 24 V DC (+10%/-5%)  
Input signal: 4 - 20 mA  
Position feedback: 0 - 10 V  
Connection: plug M12 - A-coding  
Further Information see Data sheet: KAT-PG01.

Artikel:

**ND**

Druckgesteuertes  
Regel-Nadel-Ventil  
mit stetiger Regelung

Edelstahl



Type:

**ND**

Pressure actuated  
Control-Needle-Valve  
with continuous control

Stainless steel



Alle Angaben sind freibleibend und unverbindlich!

The above information is intended for guidance only and the company reserves the right to change any data herein without prior notice!



**Artikel- u. Bestellangaben:** z.B. **ND3001801501**

Druckgesteuertes Regel-Nadel-Ventil, stetige Regelung, Edelstahlgehäuse, metallisch dichtend, Volumenstrom: 10 - 100 l/h, Edelstahl Steuerzylinder Ø63mm, G½", 4 ... 20 mA, 0 ... 10 V

1. - 2. Stelle Produkt	3. Stelle Gehäusewerkstoff	4. Stelle Dichtungen	5. - 6. Stelle Regelkegel (Volumenstrom)
<b>ND</b> = Druckgesteuertes Regel-Nadel-Ventil, stetige Regelung	<b>3</b> = Edelstahl	<b>0</b> = metallisch <b>3</b> = FKM <b>4</b> = EPDM	<b>01</b> = 10 - 100 l/h <b>02</b> = 75 - 280 l/h <b>03</b> = 200 - 800 l/h  <b>Medium: Wasser</b> <b>Δp = 1bar</b>
7. Stelle Steuerzylinder	8.- 10. Stelle Anschlussgröße	11. - 13. Stelle Steuersignal	14. - 20. Stelle Zusatzausstattungen
<b>8</b> = Edelstahl Steuerzylinder Kolben-Ø 63mm	<b>015</b> = G ½" Andere Größen und Anschlussarten auf Anfrage	<b>/01</b> = Eingang: 4 ... 20 mA Ausgang: 0 ... 10 V	Andere Steuerzylinder, Werkstoffe, Steuersignale, usw. auf Anfrage

**Ordering example:** e.g. **ND3001801501**

Pressure actuated Control-Needle-Valve, continuous control, stainless steel body, seat: metallic, flow value: 10 - 100 l/h, stainless steel pilot cylinder Ø63mm, G½", 4 ... 20 mA, 0 ... 10 V

1. - 2. Digit Product	3. Digit Body material	4. Digit Seals material	5. - 6. Digit control cone (flow value)
<b>ND</b> = Pressure actuated Control-Needle-Valve, continuous control	<b>3</b> = stainless steel	<b>0</b> = metallic <b>3</b> = FKM <b>4</b> = EPDM	<b>01</b> = 10 - 100 l/h <b>02</b> = 75 - 280 l/h <b>03</b> = 200 - 800 l/h  <b>medium: water</b> <b>Δp = 1bar</b>
7. Digit Pilot cylinder	8.- 10. Digit connection size	11. - 13. Digit Control signal	14. - 20. Digit Options
<b>8</b> = stainless steel pilot cylinder piston-Ø 63mm	<b>015</b> = G ½" Other sizes and connection types on request	<b>/01</b> = Input signal: 4 ... 20 mA output signal: 0 ... 10 V	Other pilot cylinders, materials, control signals, etc. on request.

**Elektrischer Anschluss / Electrical connections**

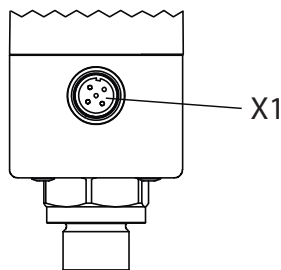

Anschluss / connection	PIN	Signalname	Signal name
<b>X1 - A-kodiert M12 - Stecker</b>  <b>X1 - A-coded M12 - plug</b>	<b>1</b>	U <sub>v</sub> , 24V DC Versorgungsspannung	U <sub>v</sub> , 24V DC Supply voltage
	<b>2</b>	I+ / U+, 4-20 mA, / 2-20mA / 0-10V Sollwerteingang	I+ / U+, 4-20 mA, / 2-20mA / 0-10V set value input
	<b>3</b>	U <sub>v</sub> , GND	U <sub>v</sub> , GND
	<b>4</b>	I+ / U+, 4-20 mA, / 2-20mA / 0-10V Istwertausgang (optional)	I+ / U+, 4-20 mA, / 2-20mA / 0-10V actual value output (optional)
	<b>5</b>	U <sub>v</sub> , Initialisierung 24V DC, Auslösung der Initialisierung mittels Impulssignal t ≥ 100 ms	U <sub>v</sub> , Initialization 24V DC, Initialization is started by an impulse signal t ≥ 100 ms



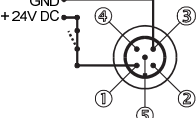

## Inbetriebnahme und Initialisierung

### Elektrischer und pneumatischer Anschluss:

<b>1.</b> Pneumatische Hilfsenergie (max. 8/10 bar) aktivieren		<b>Legende</b> LED Symbol Aus <input type="checkbox"/> An <input checked="" type="checkbox"/> Blinkt schnell Blinkt langsam
<b>2.</b> Versorgungsspannung 24V einschalten POWER LED leuchtet		OPEN ERROR CLOSED POWER <input checked="" type="checkbox"/>

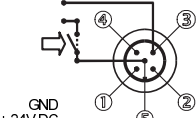
### Automatische Initialisierung:

<b>1.</b> Initialisierungsspannung 24V DC an Pin 5 anschließen und aktivieren (t > 100ms)		OPEN ERROR CLOSED POWER <input checked="" type="checkbox"/>
<b>2.</b> Initialisierungsspannung deaktivieren		OPEN ERROR <input checked="" type="checkbox"/> CLOSED POWER <input checked="" type="checkbox"/>
<b>3.</b> Die automatische Initialisierung wird durchgeführt		OPEN ERROR <input checked="" type="checkbox"/> CLOSED POWER <input checked="" type="checkbox"/>

### Inbetriebnahme:

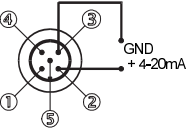
<b>1.</b> Analogen Sollwert 4-20 mA (0-20 mA/ 0-10 V) vorgeben		OPEN <input type="checkbox"/> ERROR <input type="checkbox"/> CLOSED <input type="checkbox"/> POWER <input checked="" type="checkbox"/>
<b>2.</b> Nach Beenden der Initialisierung wird das Prozessventil in die Position gemäß Sollwertsignal positioniert.	Sollwert min  Sollwert max	OPEN <input type="checkbox"/> ERROR <input type="checkbox"/> CLOSED <input checked="" type="checkbox"/> POWER <input checked="" type="checkbox"/>  OPEN <input checked="" type="checkbox"/> ERROR <input type="checkbox"/> CLOSED <input type="checkbox"/> POWER <input checked="" type="checkbox"/>



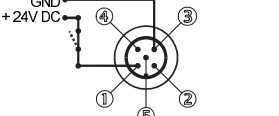

## Commissioning and initialisation

### Electrical and pneumatical connection:

<b>1.</b> Turn on pneumatic air supply (max 8/10 bar)		<b>Legend</b> LED Symbol OFF <input type="checkbox"/> ON <input checked="" type="checkbox"/> flashes fast flashes slow
<b>2.</b> Switch on 24V DC power supply POWER LED on		OPEN ERROR CLOSED POWER <input checked="" type="checkbox"/>

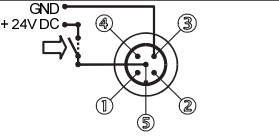
### Automatic initialisation:

<b>1.</b> Connect and activate initialisation power supply 24V DC on Pin 5 (t > 100 ms)		OPEN ERROR CLOSED POWER <input checked="" type="checkbox"/>
<b>2.</b> Disactivate initialisation power supply		OPEN ERROR <input type="checkbox"/> CLOSED POWER <input checked="" type="checkbox"/>
<b>3.</b> Automatic initialisation runs		OPEN ERROR CLOSED POWER <input checked="" type="checkbox"/>

### Commissioning:

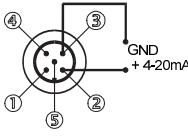
<b>1.</b> Specify an analogue set value (0-20 mA/ 0-10 V)		OPEN <input type="checkbox"/> ERROR <input type="checkbox"/> CLOSED <input type="checkbox"/> POWER <input checked="" type="checkbox"/>
<b>2.</b> After finishing the automatic initialisation the process valve were regulating in according with the set value signal	<p style="text-align: center;">Set value min</p> <p style="text-align: center;">Set value max</p>	OPEN <input type="checkbox"/> ERROR <input type="checkbox"/> CLOSED <input checked="" type="checkbox"/> POWER <input checked="" type="checkbox"/>  OPEN <input checked="" type="checkbox"/> ERROR <input type="checkbox"/> CLOSED <input type="checkbox"/> POWER <input checked="" type="checkbox"/>



**Abmessungen / Dimension :**

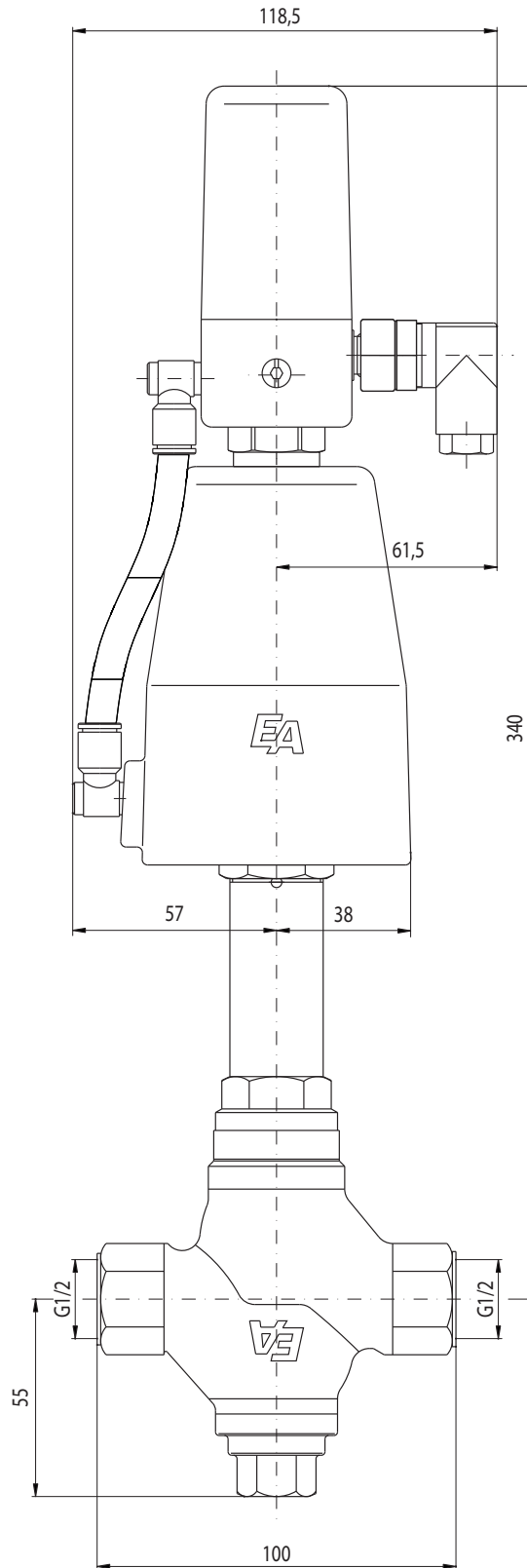

**EU-Herstellererklärung / EU-Declaration by the manufacturer**

im Sinne der EU-Maschinenrichtlinie 98/37/EG (früher 89/392/EWG, Anhang II B)  
Hiermit erklären wir, dass die druckgesteuerten Ventile unter Anwendung nachfolgender harmonisierter Normen entwickelt und konstruiert wurden:

- EN 292      Sicherheit von Maschinen
- EN 983      Fluidtechnische Anlagen - Pneumatik

as defined by Machinery Directive 98/37/EC (former 89/392/EWG, Annex II B),  
we herewith declare that the pressure actuated valves have been developed and designed by applying the following harmonised standards:

- EN 292      Safety of machinery
- EN 983      Safety requirements for fluid power systems and components - Pneumatics

**Hinweis**

Die druckgesteuerten Ventile sind zum Einbau in eine Maschine bestimmt. Deren Inbetriebnahme ist solange untersagt, bis festgestellt wurde, dass die Gesamtmaschine der EU-Richtlinie entspricht.

**Advice**

These Motor pressure actuated valves are intended to be incorporated into machinery compounds. Putting into operation of the machinery is not allowed until such time as the entire machinery is proving to comply completely with the EU Directive.

Dok-Nr.: KATND - 5/5 - 26.10.07

