



Qualität von Anfang an.

Technische Daten

BAUFORM

2-teilige Körperkonstruktion mit auswechselbarer Manschette.
Baulänge nach EN 558-1 Reihe 20.

BETÄTIGUNG

Durch Handrad mit Getriebe, elektr. od. pneu. Stellantrieb.

ANSCHLUß

Flansch DN 50 bis DN 300

BAULÄNGE

EN 558-1 Reihe 20

Nenndruck

PN 25
ANSI 150
(PN10 / PN 16 auf Anfrage)

MEDIUMTEMPERATUR

RTFE = -60°C bis max. +230°C
Metallisch = -60°C bis max. +450°C

WERKSTOFFE

Gehäuse: Stahlguß GS-C 25
Edelstahl
Scheibe: Edelstahl
Manschette: RTFE
Metallischer Sitz: Incoloy 625

ZUSATZAUSSTATTUNG

Pneumatischer oder elektrischer Schwenkantrieb, Stellungsanzeige mit elektrisch/mechanischen oder induktiven Endschaltern.

Alle Angaben sind freibleibend und unverbindlich!

Specification

DESIGN

Body consists of 2 part, with replaceable seat; Face to face dimension acc.to EN 558-1 R20.

OPERATION

By handwheel with gear box, electr. or pneu. actuator.

CONNECTION

Flange DN 50 up to DN 300

FACE TO FACE

EN 558-1 Reihe 20

Nominal pressure

PN 25
ANSI 150
(PN10 / PN16 on request)

MEDIUMTEMPERATUR

RTFE = -60°C bis max. +230°C
Metallisch = -60°C bis max. +450°C

MATERIALS

Body: Cast iron GS-C 25
Stainless steel
Disc: Stainless steel
Seat: RTFE
Metallic seat: Incoloy 625

OPTIONS

Pneumatic or electric actuator, electric position indicator with electric/mechanic or inductive proximity switches.

The above information is intended for guidance only and the company reserves the right to change any data herein without prior notice!

Artikel:
HA

Absperrklappe
für Hochtemperatur-
anwendungen
PN25

Stahlguß (GS-C 25)
Edelstahl



Type:
HA

Butterfly valve
for high temperature
applications
PN25

Cast iron(GS-C 25)
Stainless steel



Artikel- u. Bestellangaben: z.B. HA338010

= Absperrklappe, Edelstahl, Edelstahl, RTFE, DN 100

1.+ 2. Stelle Produkt	3. Stelle Gehäusewerkstoff	4. Stelle Scheibenwerkstoff	5. Stelle Manschettenwerkstoff	6. Stelle Zusatzausstattung	7.+ 8. Stelle Anschlußgröße
HA = Absperrklappe, Zwischenflansch- ausführung (LUG-Typ: Mittel- flanschausführung auf Anfrage)	3 = Edelstahl 1.4408 4 = Stahlguß GS-C 25	3 = Edelstahl 1.4408	8 = RTFE 0 = Incoloy 625	0 = ohne	07 = DN 50 08 = DN 65 09 = DN 80 10 = DN 100 11 = DN 125 12 = DN 150 13 = DN 200 14 = DN 250 15 = DN 300

Ordering example: e.g. HA338010

= Butterfly valve, Stainless steel, Stainless steel, RTFE, DN 100

1.+ 2. Digit Product	3. Digit Body material	4. Digit Disc material	5. Digit Seat material	6. Digit Options	7.+ 8. Digit Connection size
HA = Butterfly valve, (LUG-version with Drilled flanges on request)	3 = Stainless steel AISI 316 4 = cast iron GS-C 25	3 = Stainless steel 1.4408	8 = RTFE 0 = Incoloy 625	0 = no options	07 = DN 50 08 = DN 65 09 = DN 80 10 = DN 100 11 = DN 125 12 = DN 150 13 = DN 200 14 = DN 250 15 = DN 300

Erforderliche Drehmomente [Nm]¹⁾ / Torque Values [Nm]¹⁾

(Medium: Wasser , Temperatur: 20°C / medium: water , temperature: 20°C)

DN [mm]	["]	Sitzdichtung / seat: PTFE					Sitzdichtung / seat: RTFE					Sitzdichtung / seat: metallisch				
		Betriebsdruck / Working pressure					Betriebsdruck / Working pressure					Betriebsdruck / Working pressure				
		6 [bar]	10 [bar]	16 [bar]	20 [bar]	25 [bar]	6 [bar]	10 [bar]	16 [bar]	20 [bar]	25 [bar]	6 [bar]	10 [bar]	16 [bar]	20 [bar]	25 [bar]
50	2	18	20	24	32	36	22	24	30	40	45	33	36	45	60	68
65	2½	25	28	31	39	48	31	34	38	48	60	47	51	57	72	90
80	3	28	31	36	45	55	36	38	44	56	68	54	57	66	84	102
100	4	44	46	52	60	72	55	57	64	75	90	83	86	96	113	135
125	5	61	66	72	84	96	76	82	90	105	120	114	123	135	158	180
150	6	88	95	116	136	168	110	118	145	170	210	165	177	218	255	315
200	8	136	144	192	216	312	170	180	240	270	390	255	270	360	405	585
250	10	240	264	360	416	464	300	330	450	520	580	450	495	675	780	870
300	12	312	368	512	582	680	390	460	640	740	850	585	690	960	740	1275

¹⁾Die angegebenen Drehmomente enthalten keinen Sicherheitszuschlag / Above values do not include safety factor



Stückliste / Parts list (DN 125 - DN 200)

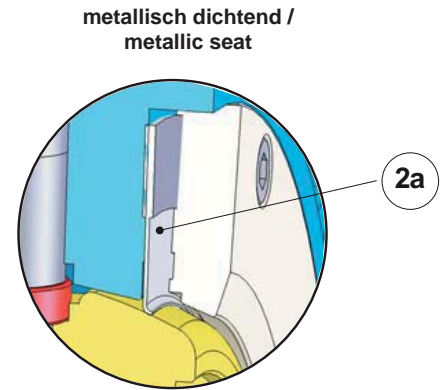
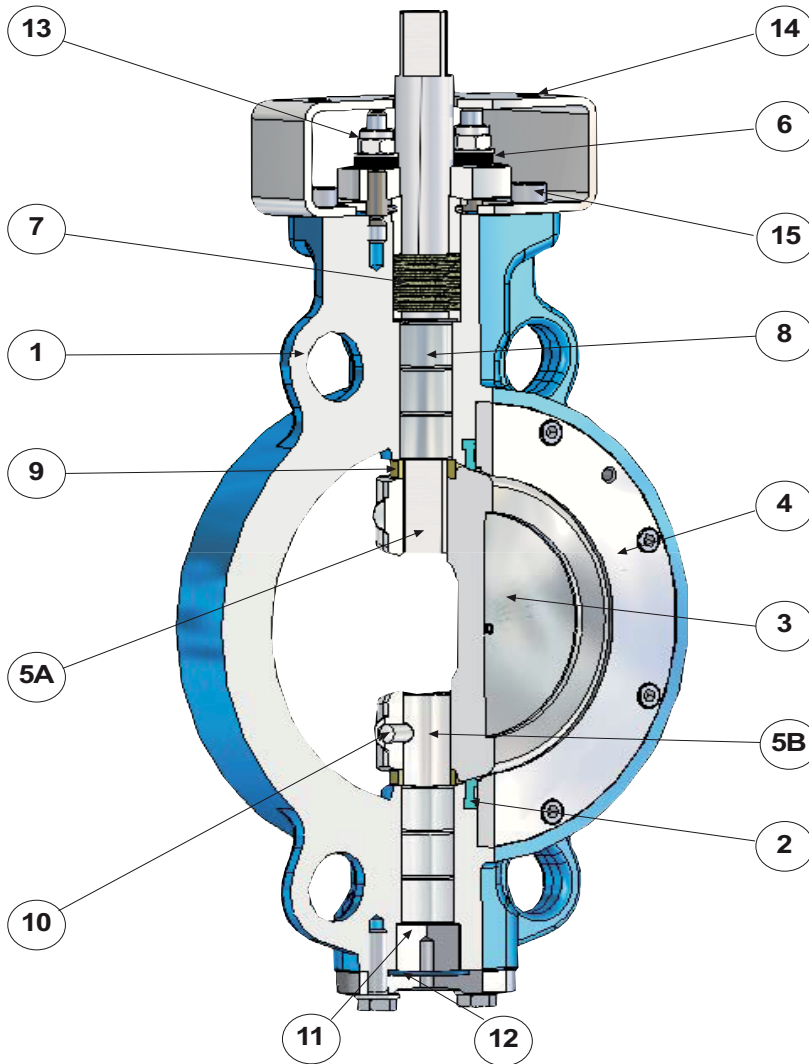

Pos.	Bezeichnung	Description	Material	Material
1	Gehäuse	Body	Stahlguß GS_C 25 Edelstahl 1.4408	ASTM A216 WCB ASTM A351 CF8M
2	Dichtung	Seat	PTFE RTFE verstärktes PTFE	PTFE RTFE reinforced PTFE
2a	met. Dichtung	met. Seat	Incoloy 625®	Incoloy 625®
3	Scheibe	Disc	Edelstahl	Stainless steel
4	Dichtflansch	Tightening flange	Edelstahl	Stainless steel
5A/5B	Spindel	Shaft	Edelstahl	Stainless steel
6	Unterlegscheibe	Thrust Washer	Edelstahl	Stainless steel
7	Packungssatz	Sealing pack	Graphit	Graphite
8	Führungsbuchse	Shaft bearing	Edelstahl + PTFE	Stainless steel + PTFE
9	Scheibe	Spacer	Edelstahl	Stainless steel
10	Spannstift	Pin	Edelstahl	Stainless steel
11	Flansch	Flange	Edelstahl	Stainless steel
12	O-Ring	O-ring	PTFE / Graphit	PTFE / Graphit
13	Gewindestift	Threaded pin	Edelstahl	Stainless steel
14	Aufbaubrücke	Top Flange (ISO 5211)	Stahl	steel
15	Schraube	Screw	Edelstahl	Stainless steel



Abmessungen Standardausführung / Dimension standard type

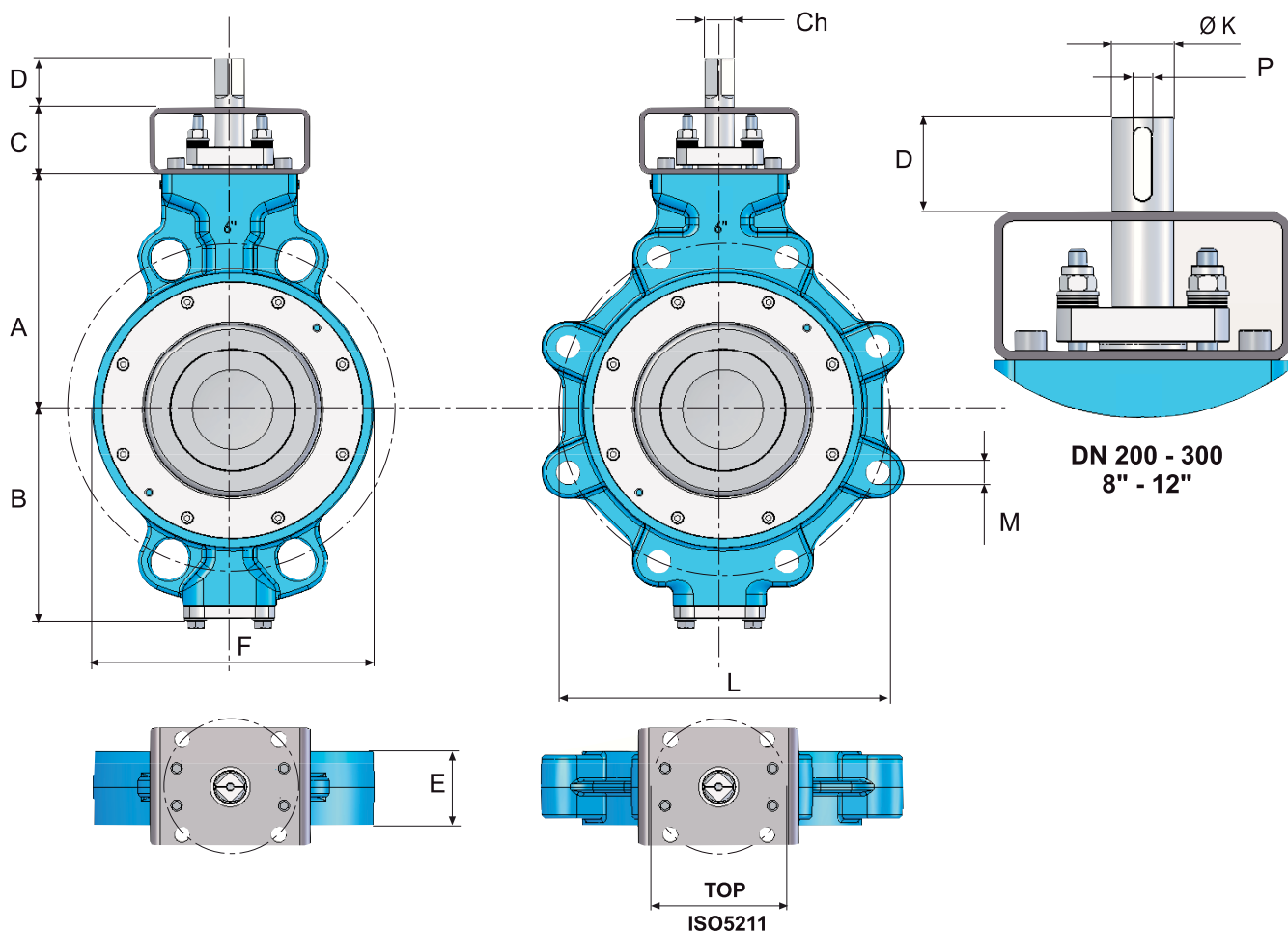

DN [mm]	["]	A [mm]	B [mm]	C [mm]	D [mm]	E [mm]	F [mm]	Top flange	ØK [mm]	Ch [mm]	P [mm]
50	2	117	81	50	34	43	95	F07	14	11	-
65	2½	120	81	50	34	46	105	F07	14	11	-
80	3	129	89	50	34	46	127	F07	14	11	-
100	4	160	128	50	34	52	150	F07	18	14	-
125	5	170	159	50	38	56	174	F10	22	17	-
150	6	179	166	50	38	56	210	F10	22	17	-
200	8	218	210	60	40	61	270	F10	25	-	8
250	10	257	232	80	60	69	325	F12	35	-	10
300	12	300	270	80	60	78	378	F12	35	-	10

DN [mm]	["]	PN 10			PN 16			PN 25			ANSI 150		
		L	n	M	L	n	M	L	n	M	L	n	M
50	2	125	4	M16	125	4	M16	125	4	M16	120,6	4	M16
65	2½	145	4	M16	145	4	M16	145	8	M16	139,7	8	M16
80	3	160	4	M16	160	4	M16	160	8	M16	152,4	8	M16
100	4	180	8	M16	180	8	M16	190	8	M20	190,5	8	M16
125	5	210	8	M16	210	8	M16	220	8	M24	215,9	8	M20
150	6	240	8	M20	240	8	M20	250	8	M24	241,3	8	M20
200	8	295	8	M20	295	12	M20	310	12	M24	298,4	12	M20
250	10	350	12	M20	355	12	M24	370	12	M27	361,9	12	M22
300	12	400	12	M20	410	12	M24	430	16	M27	431,8	16	M22

Druck - Temperatur - Diagramm / Pressure Temperature Diagram

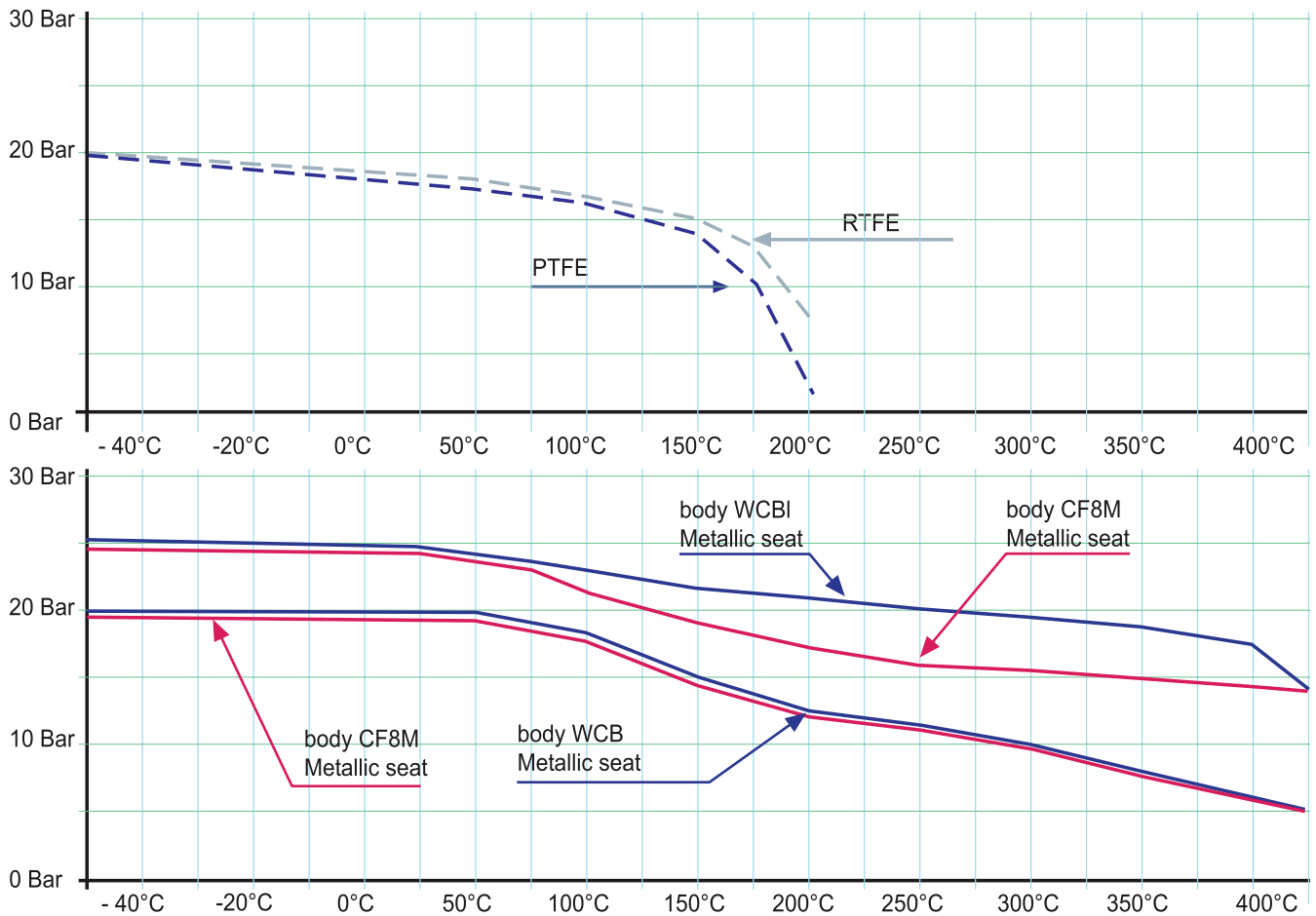

Hinweis

Bei den in dieser Dokumentation beschriebenen Produkten, in der von uns gelieferten Form, handelt es sich weder um Maschinen gemäß Artikel 2 Absatz a noch um unvollständige Maschinen gemäß Artikel 2 Absatz g im Sinne der Richtlinie 2006/42/EG über Maschinen.

Advice

The products described in this documentation in the conditions of our delivery are no machinery according to annex 2 paragraph a respectively no partly completed machinery according to annex 2 paragraph g of the directive 2006/42/EC on machinery.

