



Qualität von Anfang an.

Technische Daten

BAUFORM

Sitzventil mit Tellerdichtung

STEUERFUNKTIONEN

- In Ruhestellung durch Federkraft mit dem Mediumstrom geschlossen, durch Steuerdruck geöffnet.
Wir empfehlen die Verwendung dieser Steuerungsart nur für den Einsatz bei gasförmigen Medien. Bei flüssigen Medien besteht die Gefahr von Druckschlägen im Leitungsnetz.
- In Ruhestellung durch Federkraft gegen den Mediumstrom geschlossen, durch Steuerdruck geöffnet
- In Ruhestellung durch Federkraft geöffnet, durch Steuerdruck geschlossen
- Doppeltwirkend ohne Federrückstellung durch Steuermedium geöffnet, bzw. geschlossen

WERKSTOFFE

Gehäuse: Edelstahl
 Innenteile: Edelstahl
 Steuerzylinder: Edelstahl oder Messing verchromt
 SK125 Alu - beschichtet oder Edelstahl
 Spindeldichtung: PTFE

ANSCHLUSS

- Rohrgewinde G $\frac{1}{2}$ " ... G3" DIN ISO 228 T1
- Anschweißenden DN15 ... DN80 DIN 3239 (nur bis DN 50), ISO 4200 und DIN 11850-R2
- Flansche PN 40 (DN65 + DN80 : PN 16) Flansche PN16 - DN65 werden in 4-Loch-Ausführung geliefert!

STEUERANSCHLUß

G $\frac{1}{8}$ " ... G $\frac{1}{4}$ "

MEDIUMDRUCK

Siehe Druckbereichstabelle!

STEUERDRUCK

2 ... 10bar, Standard 6 ... 10bar (andere auf Anfrage)

DURCHFLUSSMEDIUM

Gasförmige und flüssige Medien. (aggressive Medien auf Anfrage.)

VISKOSITÄT

≤ 400mm²/s

MEDIUMTEMPERATUR

-30°C ... +180°C

UMGEBUNGSTEMPERATUR

max. +80°C

STEUERMEDIUM

Luft, Wasser (Öl auf Anfrage)

EINBAULAGE

beliebig

ZUSATZAUSSTATTUNG

optische Stellungsanzeige, elektrische Stellungsanzeigen, Handbetätigung, mechanische Hubbegrenzung, öl- und fettfrei, Vakuumausführung, Hygiene Ausführung.

Alle Angaben sind freibleibend und unverbindlich!

Specification

DESIGN

Seat valve with disk sealing

OPERATION

- Single acting to close in flow direction. Opened by pilot pressure.
We recommend the use of this operation mode only at gaseous media. The using of liquid media could causes pressure shocks in the pipes.
- Single acting to close against flow direction. Opened by pilot pressure.
- Single acting to open. Closing by pilot pressure.
- Double-acting. Closed and opened by pilot pressure.

MATERIAL

Body: Stainless steel
 Internal parts: Stainless steel
 Cylinder: stainless steel or brass chrome-plated
 SK 125 AL or stainless steel
 Spindle seal: PTFE

CONNECTION

- Threaded connection G $\frac{1}{2}$ " ... G3" DIN ISO 228 T1
- Butt weld DN15 ... DN80 DIN 3239 (only up to DN 50), ISO 4200 and DIN 11850-R2
- Flanges PN 40 (DN65 + DN80 : PN 16) Flanges PN16 - DN65 will be delivered in 4-hole execution!

PILOT PORT

G $\frac{1}{8}$ " ... G $\frac{1}{4}$ "

PRESSURE RANGE

See table overleaf

PILOT PRESSURE

2 ... 10bar, standard 6 ... 10bar (others on request)

MEDIA

Liquids and gases. (aggressive media on request.)

VISCOSITY

≤ 400mm²/s

TEMPERATURE RANGE

-30°C ... +180°C

TEMPERATURE OF THE ENVIRONMENT

max. +80°C

PILOT MEDIA

Air, water (oil on request)

INSTALLATION

As desired

OPTIONS

Optical position indicator, electrical position indicator, position indication by inductive proximity switch, magnetic switch, manual override, mechanical lift stop, free of oil and grease, for vacuum applications. Hygienic Version (Food)

The above information is intended for guidance only and the company reserves the right to change any data herein without prior notice!

Artikel: **DG2D3**
DA2D3
DL2D3
DM2D3

2/2-Wege-Ventil
direktgesteuert

Edelstahl



Type: **DG2D3**
DA2D3
DL2D3
DM2D3

2/2-way valve
direct acting

Stainless steel



auch lieferbar nach /
also available acc.to



Artikel- u. Bestellangaben: z.B. DG2D3115025/OS

= Druckgesteuertes Ventil, Edelstahl / PTFE, Ruhe zu, mit dem Medium schließend, Edelstahlzylinder, G 1", mit optischer Stellungsanzeige

1. Stelle Produkt	2. Stelle Anschlußart	3. Stelle Wege	4. Stelle Steuerungsart	5. Stelle Gehäusewerkstoff	6. Stelle Dichtungswerkstoff
D = druckgesteuertes Ventil	G = Gewindean- schluss A = Anschweißen- den DIN 3239 L = Anschweißen- den ISO 4200 M = Anschwei- ßenenden DIN 11850-R2	2 = 2/2-Wege	D = direktgesteuert	3 = Edelstahl	1 = PTFE 2 = NBR 3 = FKM 4 = EPDM
7. Stelle Steuerfunktion	8. Stelle Kolben Ø	9. - 11. Stelle Anschluß		12. - 20. Stelle Zustausstattungen	
1 = Ruhe zu, mit dem Medium schließend 2 = Ruhe zu, gegen das Medium schließend 3 = Ruhe auf, gegen das Medium schließend 4 = doppeltwirkend	Messingzylinder 0 = Ø 32mm 1 = Ø 50mm 2 = Ø 80mm 3 = Ø 125mm 4 = Ø 63mm Edelstahlzylinder 5 = Ø 50mm 6 = Ø 80mm 7 = Ø 125mm 8 = Ø 63mm 9 = Ø 32mm	015 = G ½ 020 = G ¾ 025 = G 1 032 = G 1¼ 040 = G 1½ 050 = G 2 065 = G 2½ 080 = G 3	Anschweiß- enden DN15 DN20 DN25 DN32 DN40 DN50 DN65 DN80	ES = elektr./mech. Stellungsanzeige FL = angeschweißte Flansche PN 16 HB = Hubbegrenzung HN = Handnotbetätigung HY = Hygiene Ausführung HO = Hubbegrenzung und optische Stellungsanzeige NI = induktive Stellungsanzeige OF = öl- und fettfrei OG = ohne Gehäuse OS = optische Stellungsanzeige NS = elektr. Stellungsanzeige (Reed-Kontakt) V = für Vakuum VD = für Vakuum und Druck	

Ordering example: e.g. DG2D3115025/OS

= Pressure actuated valve, stainless steel / PTFE, single acting to close in flow direction, stainless steel cylinder, G 1", with optical position indicator

1. Digit Product	2. Digit Connection	3. Digit Ways	4. Digit Operation	5. Digit Body material	6. Digit Sealing material
D = pressure actuated valve	G = threaded con- nection A = butt welding DIN 3239 L = butt welding ISO 4200 M = butt welding DIN 11850-R2	2 = 2/2-ways	D = direct acting	3 = Stainless steel	1 = PTFE 2 = NBR 3 = FKM 4 = EPDM
7. Digit Operation	8. Digit Actuator Ø	9. - 11. Digit Connection size		12. - 20. Digit Options	
1 = Single acting to close in flow direction 2 = Single acting to close against flow direction 3 = Single acting to open, closing by pilot pressure 4 = double acting	Brass cylinder 0 = Ø 32mm 1 = Ø 50mm 2 = Ø 80mm 3 = Ø 125mm 4 = Ø 63mm Stainless steel cylinder 5 = Ø 50mm 6 = Ø 80mm 7 = Ø 125mm 8 = Ø 63mm 9 = Ø 32mm	015 = G ½ 020 = G ¾ 025 = G 1 032 = G 1¼ 040 = G 1½ 050 = G 2 065 = G 2½ 080 = G 3	threaded- connection DN15 DN20 DN25 DN32 DN40 DN50 DN65 DN80	ES = electr./mech. position indicator FL = Flange PN 16 HB = mechanical lift stop HN = manual override HY = hygienic version (Food) HO = mechanical lift stop and optical position indicator NI = inductive proximity switches OF = free of oil and grease OG = without body OS = optical position indicator NS = proximity switches (Reed-contact) V = for vacuum applications VD = for vacuum and pressure applications	

Unsere Empfehlung / We recommend

Art. MGAG3D13xx43420

Als Steuerventile empfehlen wir
unsere 3/2-Wege Magnetventile /
For pilot valves we recommend our
3/2-ways solenoid valves



Art. MEAG3D33xx43420

Funktionsprinzip von druckgesteuerten Ventilen / Function principle of pressure actuated valves

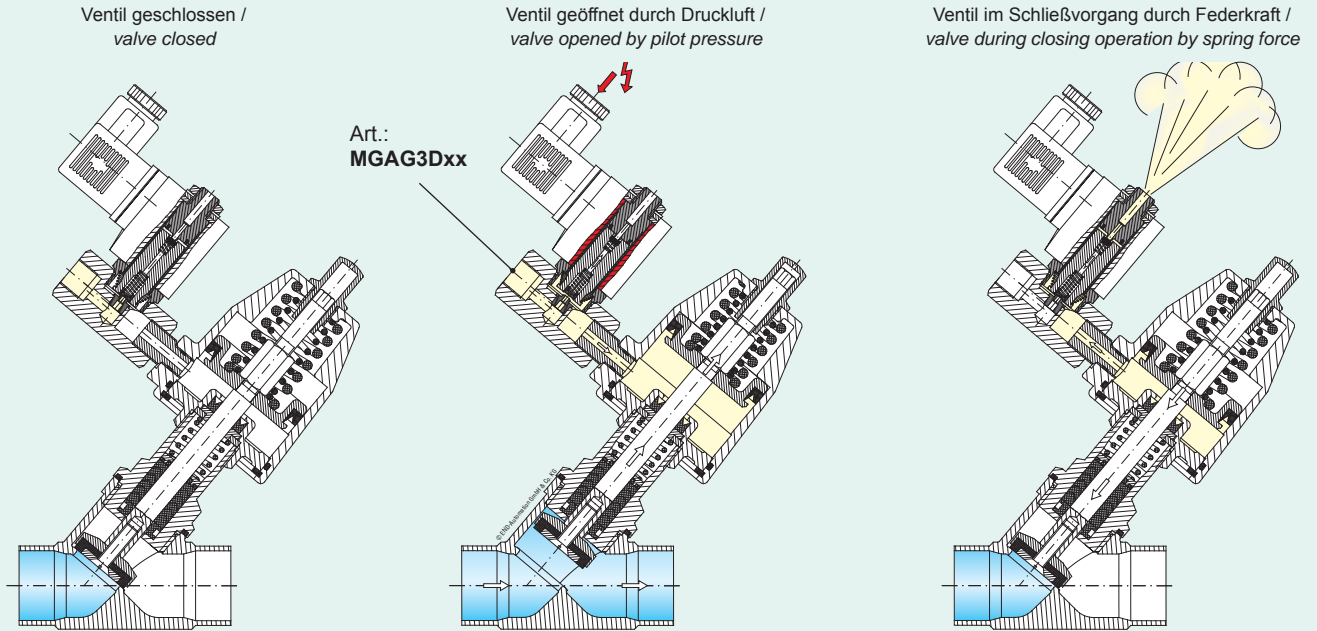

Steuerungsarten bei druckgesteuerten Ventilen / Operation systems of pressure actuated valves

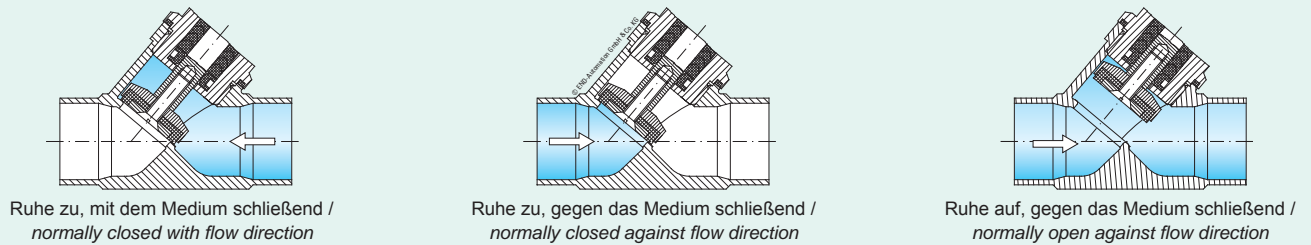

Max. Mediumdruck [bar] bei 6bar Steuerdruck / Max. medium pressure [bar] at 6bar pilot pressure

Steuerungsart / Operation systems		Ruhe zu, mit dem Medium schließend / Single acting to close in flow direction					Ruhe zu, gegen das Medium schließend / Single acting to close against flow direction					Ruhe auf, gegen das Medium schließend / Single acting to open, closing by pilot pressure			
Anschluß / Connection		Steuerkolben Ø [mm] / Actuator Ø [mm]					Steuerkolben Ø [mm] / Actuator Ø [mm]					Steuerkolben Ø [mm] / Actuator Ø [mm]			
G	DN	32	50	63	80	125	32	50	63	80	125	50	63	80	125
½	15	16	25	40	-	-	10	25	-	-	-	40	40	-	-
¾	20	12	25	40	-	-	6	12	-	-	-	25	40	-	-
1	25	6,5	18	25	40	-	3	8	18	32	-	16	25	40	-
1¼	32	-	10	16	30	-	-	4	10	20	-	8	15	25	-
1½	40	-	8	12	20	-	-	2	8	15	-	6	10	18	-
2	50	-	5	8	14	30	-	0,5	4,5	8	12	3	6	12	30
2½	65	-	-	4,5	7	16	-	-	2	4	8,5	-	3	5	16
3	80	-	-	3	5	12	-	-	1	3	6	-	2	3	10

Durchflusswert [m³/h] bei Δp = 1bar / Flow rate [m³/h] at Δp = 1bar

G	½	¾	1	1¼	1½	2	2½	3
DN	15	20	25	32	40	50	65	80
Steuerkolben Ø 32mm / actuator Ø 32mm								
Kv	3,2	6,4	9,5	-	-	-	-	-
Steuerkolben Ø 50mm / actuator Ø 50mm								
Kv	4,6	9,5	10,5	21	26,5	31	-	-
Steuerkolben Ø 63mm / actuator Ø 63mm								
Kv	-	-	12	24	30	42	62	85
Steuerkolben Ø 80mm / actuator Ø 80mm								
Kv	-	-	13,5	29	40	49	68	96
Steuerkolben Ø 125mm / actuator Ø 125mm								
Kv	-	-	-	-	-	62	85	120

Stückliste / Parts list:

Steuerkolben Ø 32mm/
Actuator Ø 32mm

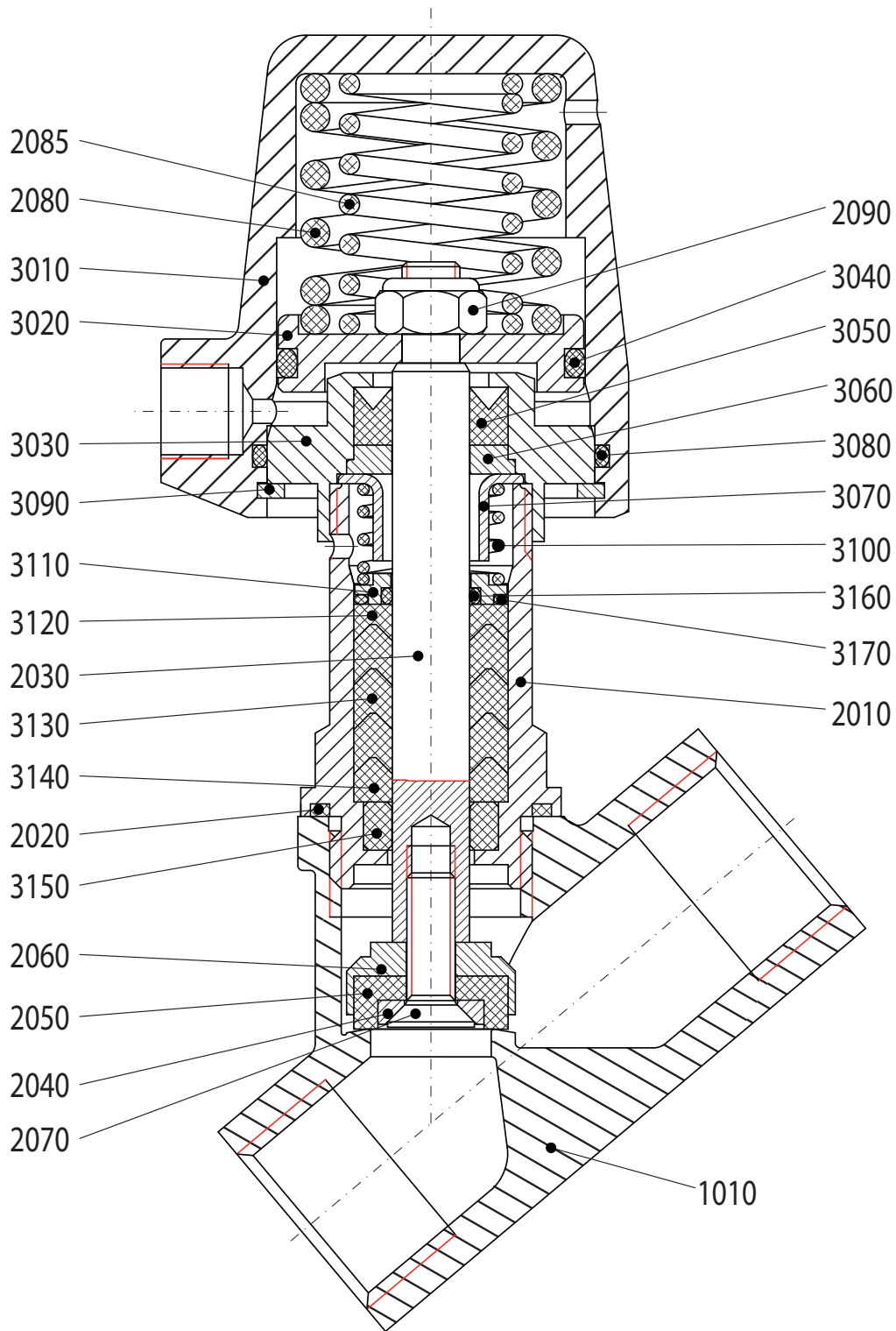

Stückliste / Parts list:

Steuerkolben Ø 32mm/
Actuator Ø 32mm

No	Bezeichnung	Description	Material	Material
1010	Gehäuse	body	Edelstahl 1.4408	stainless steel 1.4408
2010	Einschraubteil	screw joint	Edelstahl 1.4408	stainless steel 1.4408
2020	Dichtring	sealing	PTFE	PTFE
2030	Spindel	spindle	Edelstahl	stainless steel
2040	Scheibe	disc	Edelstahl	stainless steel
2050	Sitzdichtung	seat sealing	PTFE NBR FKM EPDM	PTFE NBR FKM EPDM
2060	Ventilteller	valve disc	Edelstahl	stainless steel
2070	Innensechskantschraube	screw	Edelstahl	stainless steel
2080	Druckfeder	spring	Edelstahl	stainless steel
2085	Druckfeder	spring	Edelstahl	stainless steel
2090	Sechskantmutter	hexagon nut	Edelstahl	stainless steel
3010	Steuerzylinder	cylinder	Edelstahl Messing verchromt	stainless steel brass chrome-plated
3020	Kolben	piston	Edelstahl Messing	stainless steel brass
3030	Deckel	cap	Edelstahl Messing verchromt	stainless steel brass chrome-plated
3040	O-Ring	o-ring	FKM	FKM
3050	Nutring	lip seal	HNBR	HNBR
3060	T- Führungsring	T- guide ring	PTFE Kohlefaser verstärkt	PTFE carbon reinforced
3070	Distanzstück	distance part	Edelstahl	stainless steel
3080	O-Ring	o-ring	FKM	FKM
3090	Sicherungsring	locking ring	Edelstahl	stainless steel
3100	Druckfeder	spring	Edelstahl	stainless steel
3110	Scheibe	disc	Edelstahl	stainless steel
3120	Druckring	pressure ring	PTFE glasfaserverstärkt	PTFE glass fibre reinforced
3130	V- Manschettensatz	V- packing	PTFE glasfaserverstärkt	PTFE glass fibre reinforced
3140	Stützring	base ring	PTFE glasfaserverstärkt	PTFE glass fibre reinforced
3150	Führungsring	guide ring	PTFE Kohlefaser verstärkt	PTFE carbon reinforced
3160	O-Ring	o-ring	FKM	FKM
3170	O-Ring	o-ring	FKM	FKM



Stückliste / Parts list:

Steuerkolben Ø 50mm/
Actuator Ø 50mm

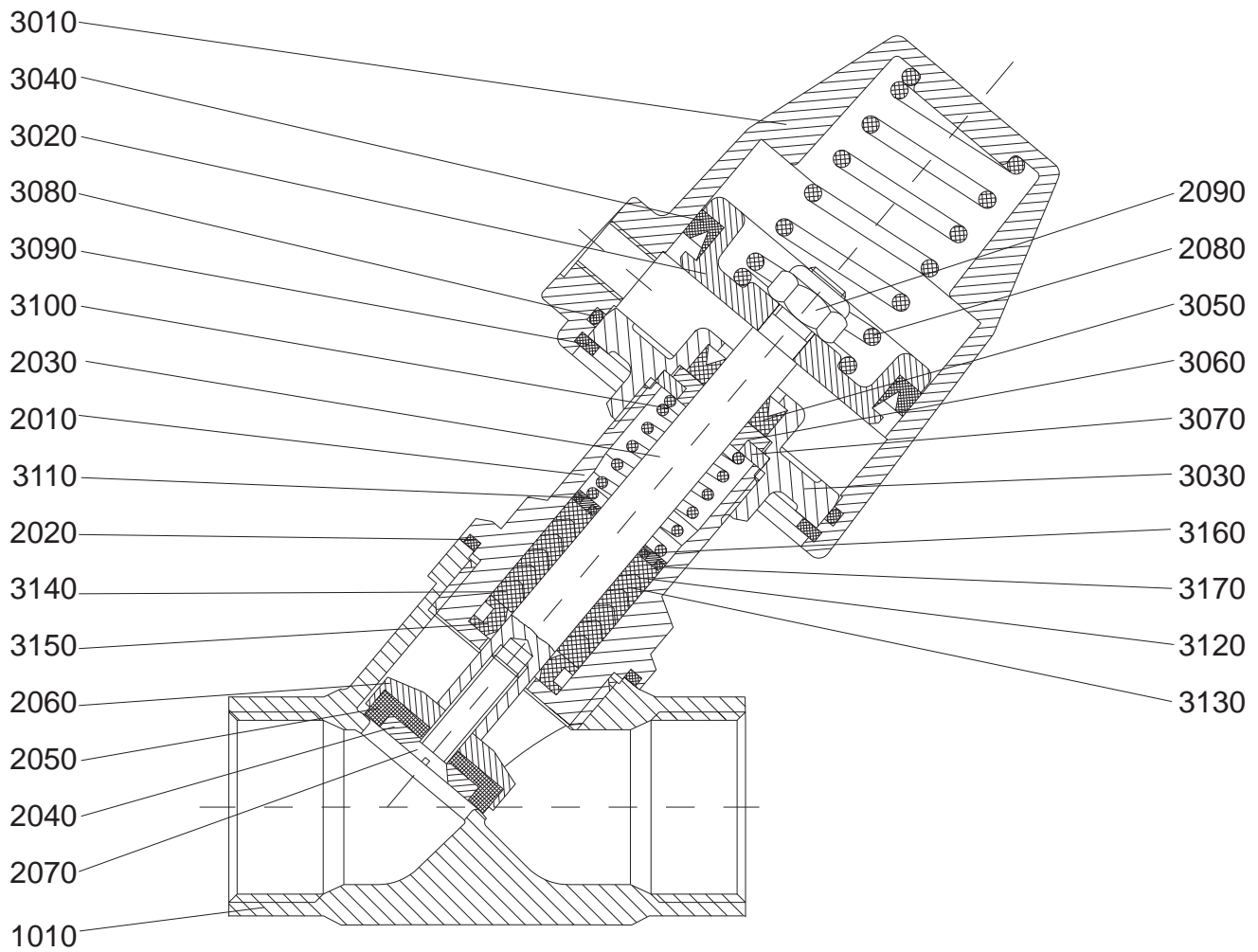

Stückliste / Parts list:

Steuerkolben Ø 50mm/ Actuator Ø 50mm

No	Bezeichnung	Description	Material	Material
1010	Gehäuse	body	Edelstahl 1.4408	stainless steel 1.4408
2010	Einschraubteil	screw joint	Edelstahl 1.4408	stainless steel 1.4408
2020	Dichtring	sealing	PTFE	PTFE
2030	Spindel	spindle	Edelstahl	stainless steel
2040	Scheibe	disc	Edelstahl	stainless steel
2050	Sitzdichtung	seat sealing	PTFE NBR FKM EPDM	PTFE NBR FKM EPDM
2060	Ventilteller	valve disc	Edelstahl	stainless steel
2070	Innensechskantschraube	screw	Edelstahl	stainless steel
2080	Druckfeder	spring	Edelstahl	stainless steel
2090	Sechskantmutter	hexagon nut	Edelstahl	stainless steel
3010	Steuerzylinder	cylinder	Edelstahl Messing verchromt	stainless steel brass chrome-plated
3020	Kolben	piston	Edelstahl Messing	stainless steel brass
3030	Deckel	cap	Edelstahl Messing verchromt	stainless steel brass chrome-plated
3040	Nutring	lip seal	HNBR	HNBR
3050	Nutring	lip seal	HNBR	HNBR
3060	T- Führungsring	T- guide ring	PTFE glasfaserverstärkt	PTFE glass fibre reinforced
3070	Scheibe	disc	Edelstahl Messing	stainless steel brass
3080	O-Ring	o-ring	FKM	FKM
3090	Sicherungsring	locking ring	Edelstahl	stainless steel
3100	Druckfeder	spring	Edelstahl	stainless steel
3110	Scheibe	disc	Edelstahl	stainless steel
3120	Druckring	pressure ring	PTFE glasfaserverstärkt	PTFE glass fibre reinforced
3130	V- Manschettensatz	V- packing	PTFE glasfaserverstärkt	PTFE glass fibre reinforced
3140	Stützring	base ring	PTFE glasfaserverstärkt	PTFE glass fibre reinforced
3150	Führungsring	guide ring	PTFE mit Bronze	PTFE with bronze
3160	O-Ring	o-ring	FKM	FKM
3170	O-Ring	o-ring	FKM	FKM



Stückliste / Parts list:

Steuerkolben Ø 63mm/
Actuator Ø 63mm

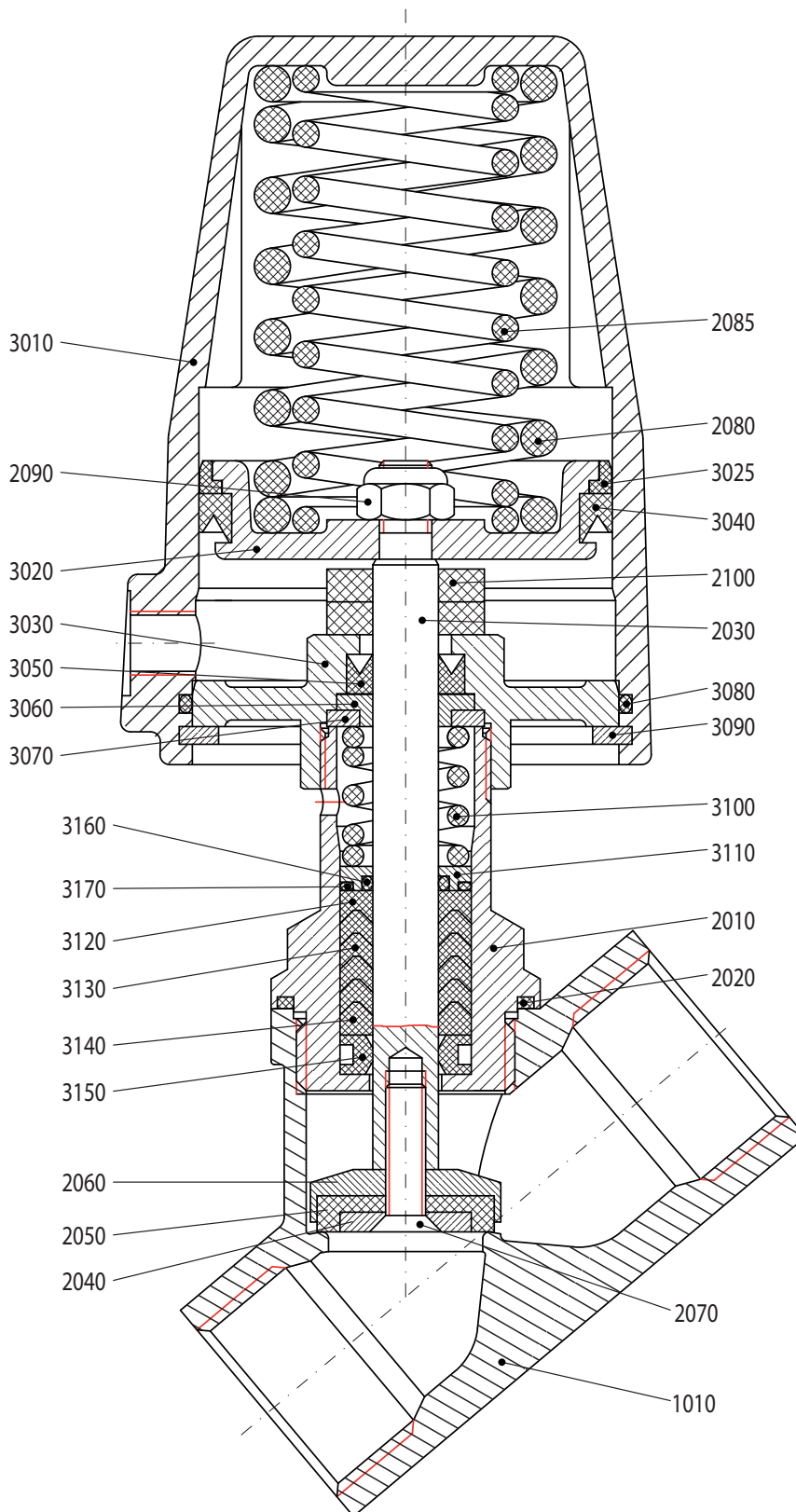

Stückliste / Parts list:

Steuerkolben Ø 63mm/
Actuator Ø 63mm

No	Bezeichnung	Description	Material	Material
1010	Gehäuse	body	Edelstahl 1.4408	stainless steel 1.4408
2010	Einschraubteil	screw joint	Edelstahl 1.4408	stainless steel 1.4408
2020	Dichtring	sealing	PTFE	PTFE
2030	Spindel	spindle	Edelstahl	stainless steel
2040	Scheibe	disc	Edelstahl	stainless steel
2050	Sitzdichtung	seat sealing	PTFE NBR FKM EPDM	PTFE NBR FKM EPDM
2060	Ventilteller	valve disc	Edelstahl	stainless steel
2070	Innensechskantschraube	screw	Edelstahl	stainless steel
2080	Druckfeder	spring	Edelstahl	stainless steel
2085	Druckfeder	spring	Edelstahl	stainless steel
2090	Sechskantmutter	hexagon nut	Edelstahl	stainless steel
2100	Distanzstück	distance part	PA	PA
3010	Steuerzylinder	pilot cylinder	Edelstahl Messing verchromt	stainless steel brass chrome-plated
3020	Kolben	piston	Edelstahl Messing	stainless steel brass
3025	Führung	guide ring	POM	POM
3030	Deckel Steuerzylinder	cap pilot cylinder	Edelstahl Messing verchromt	stainless steel brass chrome-plated
3040	Nutring	lip seal	HNBR	HNBR
3050	Nutring	lip seal	HNBR	HNBR
3060	T- Führungsring	T- guide ring	PTFE glasfaserverstärkt	PTFE glass fibre reinforced
3070	Scheibe	disc	Edelstahl Messing	stainless steel brass
3080	O-Ring	o-ring	FKM	FKM
3090	Sicherungsring	locking ring	Edelstahl	stainless steel
3100	Druckfeder	spring	Edelstahl	stainless steel
3110	Scheibe	disc	Edelstahl	stainless steel
3120	Druckring	pressure ring	PTFE glasfaserverstärkt	PTFE glass fibre reinforced
3130	V- Manschettensatz	V- packing	PTFE glasfaserverstärkt	PTFE glass fibre reinforced
3140	Stützring	base ring	PTFE glasfaserverstärkt	PTFE glass fibre reinforced
3150	Führungsring	guide ring	PTFE mit Bronze	PTFE with bronze
3160	O-Ring	o-ring	FKM	FKM
3170	O-Ring	o-ring	FKM	FKM



Stückliste / Parts list:

Steuerkolben Ø 80mm/
Actuator Ø 80mm

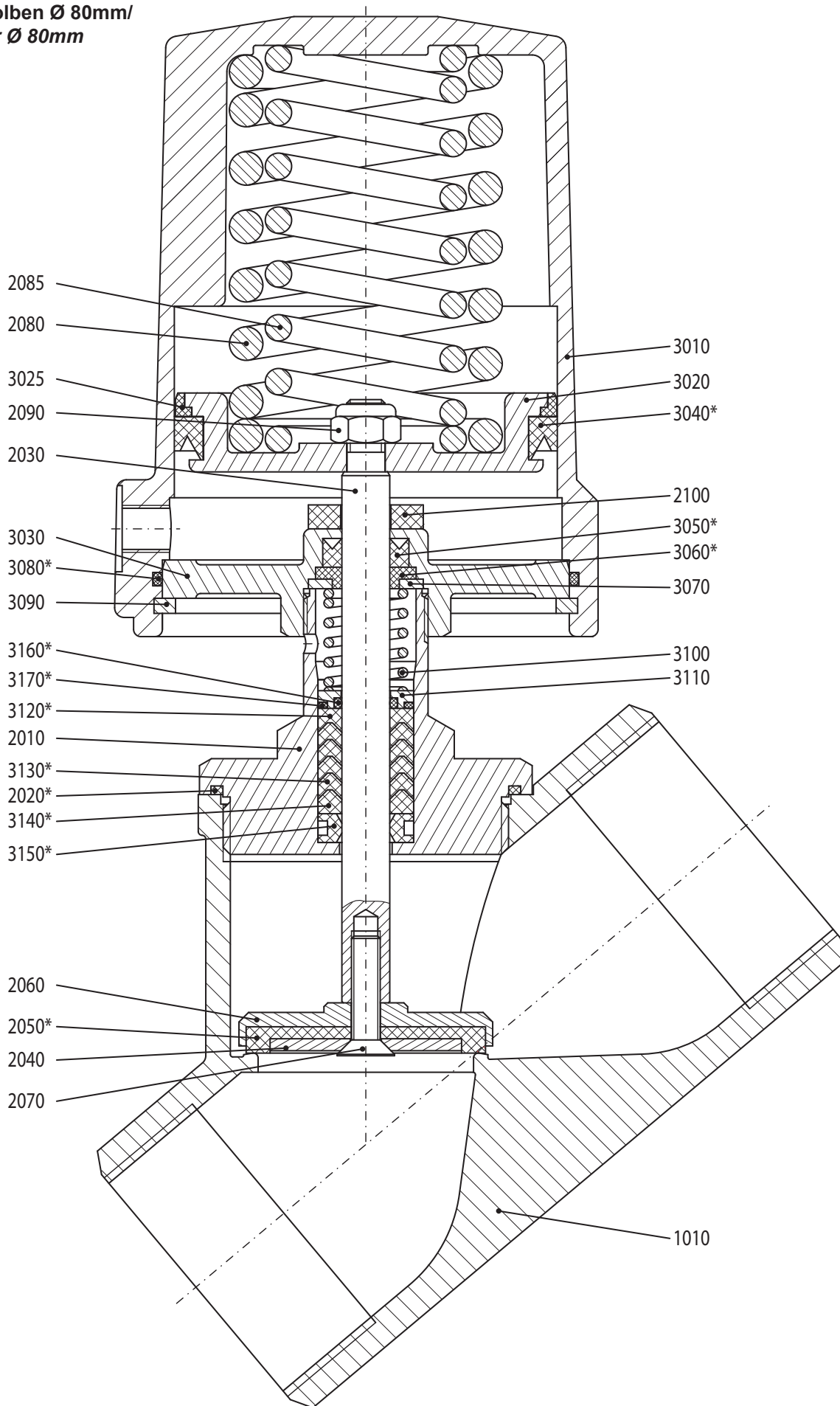

Stückliste / Parts list:

Steuerkolben Ø 80mm/ Actuator Ø 80mm

No	Bezeichnung	Description	Material	Material
1010	Gehäuse	body	Edelstahl 1.4408	stainless steel 1.4408
2010	Einschraubteil	screw joint	Edelstahl 1.4408	stainless steel 1.4408
2020	Dichtring	sealing	PTFE	PTFE
2030	Spindel	spindle	Edelstahl	stainless steel
2040	Scheibe	disc	Edelstahl	stainless steel
2050	Sitzdichtung	seat sealing	PTFE NBR FKM EPDM	PTFE NBR FKM EPDM
2060	Ventilteller	valve disc	Edelstahl	stainless steel
2070	Innensechskantschraube	screw	Edelstahl	stainless steel
2080	Druckfeder	spring	Edelstahl	stainless steel
2085	Druckfeder	spring	Edelstahl	stainless steel
2090	Sechskantmutter	hexagon nut	Edelstahl	stainless steel
2100	Distanzstück	distance part	PA	PA
3010	Steuerzylinder	pilot cylinder	Edelstahl Messing verchromt	stainless steel brass chrome-plated
3020	Kolben	piston	Edelstahl Messing	stainless steel brass
3025	Führung	guide ring	POM	POM
3030	Deckel Steuerzylinder	cap pilot cylinder	Edelstahl Messing verchromt	stainless steel brass chrome-plated
3040	Nutring	lip seal	HNBR	HNBR
3050	Nutring	lip seal	HNBR	HNBR
3060	T- Führungsring	T- guide ring	PTFE glasfaserverstärkt	PTFE glass fibre reinforced
3070	Scheibe	disc	Edelstahl Messing	stainless steel brass
3080	O-Ring	o-ring	FKM	FKM
3090	Sicherungsring	locking ring	Edelstahl	stainless steel
3100	Druckfeder	spring	Edelstahl	stainless steel
3110	Scheibe	disc	Edelstahl	stainless steel
3120	Druckring	pressure ring	PTFE glasfaserverstärkt	PTFE glass fibre reinforced
3130	V- Manschettensatz	V- packing	PTFE glasfaserverstärkt	PTFE glass fibre reinforced
3140	Stützring	base ring	PTFE glasfaserverstärkt	PTFE glass fibre reinforced
3150	Führungsring	guide ring	PTFE mit Bronze	PTFE with bronze
3160	O-Ring	o-ring	FKM	FKM
3170	O-Ring	o-ring	FKM	FKM



Stückliste / Parts list:

**Steuerkolben Ø 125mm/
Actuator Ø 125mm**

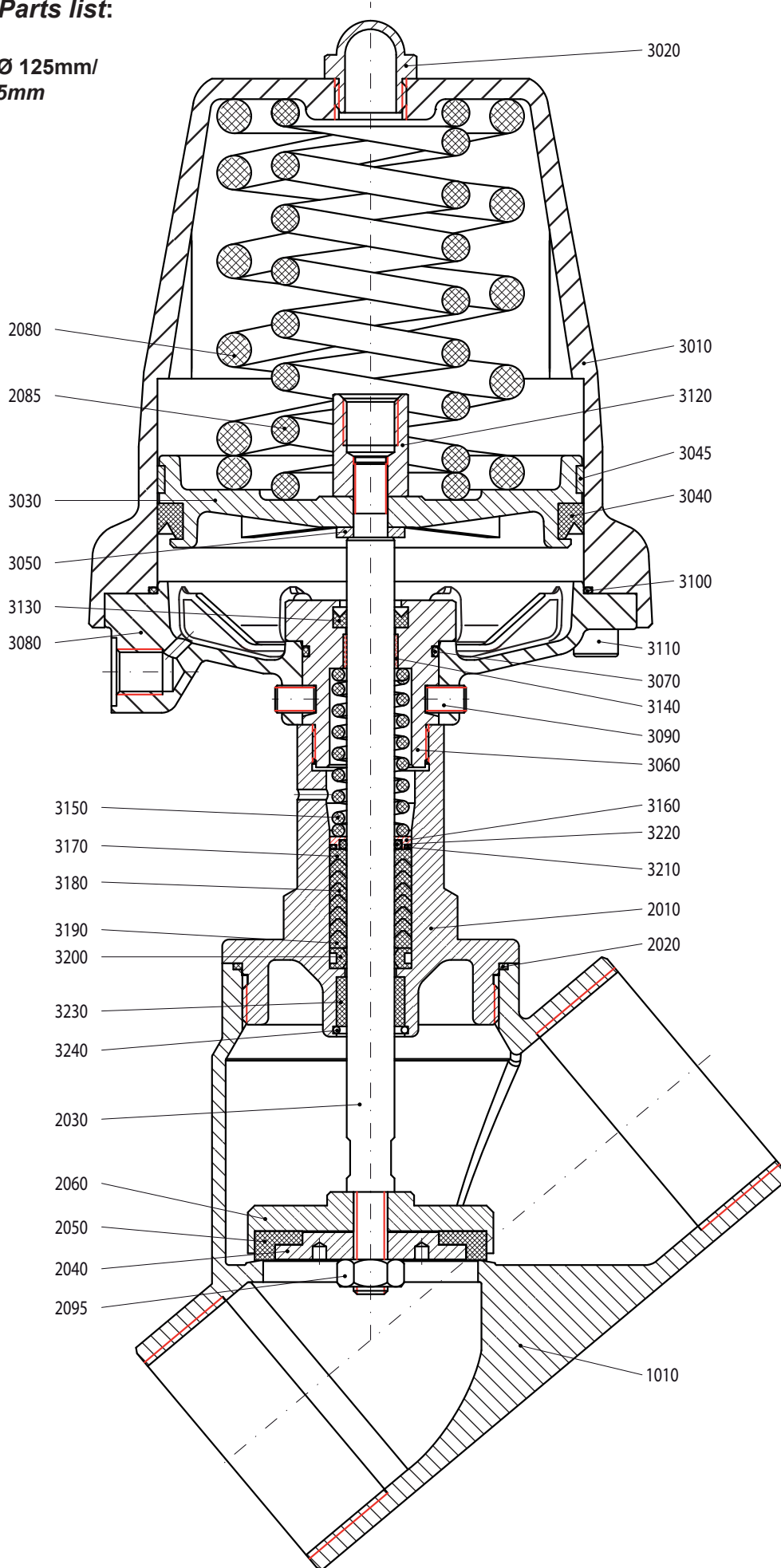

Stückliste / Parts list:

Steuerkolben Ø 125mm/
Actuator Ø 125mm

No	Bezeichnung	Description	Material	Material
1010	Gehäuse	body	Edelstahl 1.4408	stainless steel 1.4408
2010	Einschraubteil	screw joint	Edelstahl 1.4404	stainless steel 1.4408
2020	Dichtring	sealing	PTFE	PTFE
2030	Spindel	spindle	Edelstahl	stainless steel
2040	Scheibe	disc	Edelstahl	stainless steel
2050	Sitzdichtung	sealing	PTFE NBR FKM EPDM	PTFE NBR FKM EPDM
2060	Ventilteller	valve disc	Edelstahl	stainless steel
2080	Druckfeder	spring	Edelstahl	stainless steel
2081	Druckfeder	spring	Edelstahl	stainless steel
2095	Sechskantmutter	hexagon nut	Edelstahl	stainless steel
3010	Steuerzylinder	pilot cylinder	Aluminium	aluminium
3020	Abdeckkappe	cap	Edelstahl 1.4408	stainless steel 1.4408
3030	Kolben	piston	Aluminium	aluminium
3040	Nutring	lip seal	FKM	FKM
3045	Führungsband	guide band	PTFE mit Bronze	PTFE with bronze
3050	Scheibe	disc	Edelstahl	stainless steel
3060	Einschraubteil	screw joint	Messing	brass
3070	O- Ring	o-ring	FKM	FKM
3090	Gewindestift	threaded pin	Edelstahl	stainless steel
3100	O-Ring	o-ring	FKM	FKM
3110	Innsechskantschraube	allen screw	Edelstahl	stainless steel
3120	Verbindungsmutter	union nut	Edelstahl	stainless steel
3130	Nutring	lip seal	FKM	FKM
3140	Gleitbuchse	sleeve	PTFE-Pb -Stahlrücken	PTFE-Pb -steel back
3150	Druckfeder	spring	Edelstahl	stainless steel
3160	Scheibe	disc	Edelstahl	stainless steel
3170	Druckring	pressure ring	PTFE glasfaserverstärkt	PTFE glass fibre reinforced
3180	V- Manschettensatz	V-packing	PTFE glasfaserverstärkt	PTFE glass fibre reinforced
3190	Stützring	base ring	PTFE glasfaserverstärkt	PTFE glass fibre reinforced
3200	Führungsring	guide ring	PTFE mit Bronze	PTFE with bronze
3210	O- Ring	o-ring	FKM	FKM
3220	O- Ring	o-ring	FKM	FKM
3230	Führungsbuchse	guide bush	PTFE glasfaserverstärkt	PTFE glass fibre reinforced
3240	Sprengring	snap ring	Edelstahl 1.4571	stainless steel 1.4571

Dok.-Nr.: KAT-DG(A)(L)(M)2D3-13/22 - 26.02.10 - Änderung: Steuerzylinder Ø125mm alle Version gelb-sch



Abmessungen [mm] / Dimension [mm]:

Steuerkolben Ø 32mm/
Actuator Ø 32mm

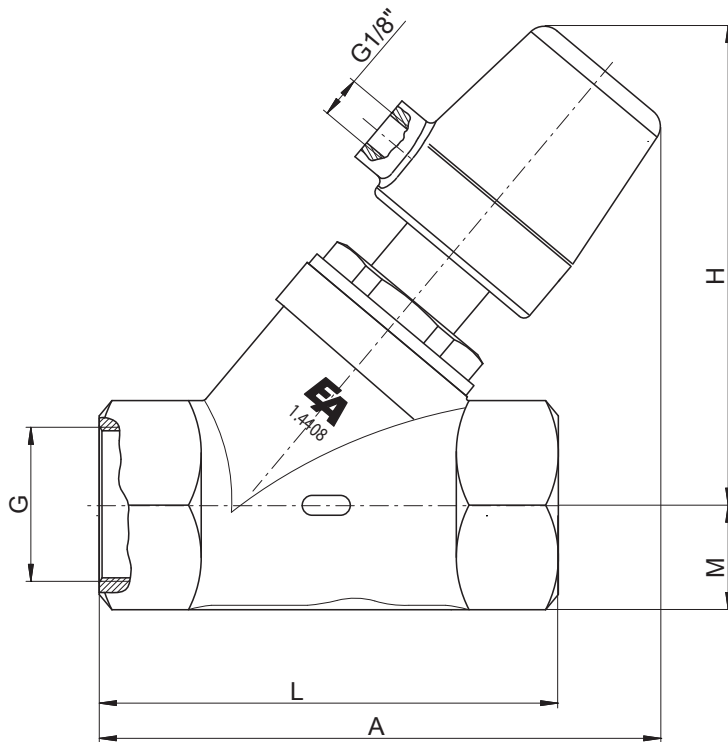

"A"- Anschweißenden DIN 3239
"A"- Butt welding DIN 3239

"L"- Anschweißenden ISO 4200
"L"- Butt welding ISO 4200

"M"- Anschweißenden DIN 11850-2
"M"- Butt welding DIN 11850-2

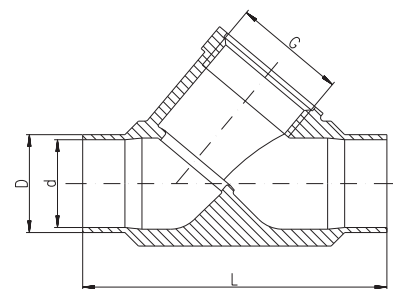
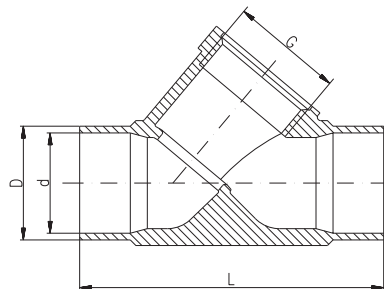
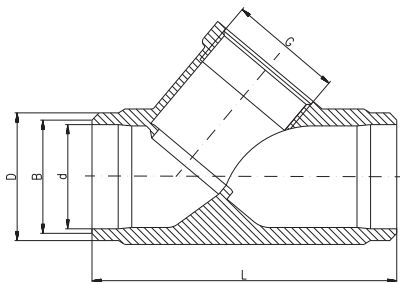

G	DN	DIN 3239			ISO 4200		DIN 11850-2		L	A	M ⁽¹⁾	M ⁽²⁾	H	kg
		D	B	d	D	d	D	d						
1/2	15	24	22	17	21,3	18,1	19	16	65	103	13,5	12,5	95,5	0,56
3/4	20	30	28	22	26,9	23,7	23	20	75	108	16,0	15,5	99,0	0,75
1	25	36	34	28	33,7	29,7	29	26	90	116	20,5	18,5	102,5	0,97

Alle Angaben für Standardausführung /
The above informations are for standard type

⁽¹⁾ Gehäuse mit Gewindeanschluß / body with thread connection
⁽²⁾ Gehäuse mit Anschweißenden / body with welded connection



Abmessungen [mm] / Dimension [mm]:

Steuerkolben Ø 50mm/
Actuator Ø 50mm

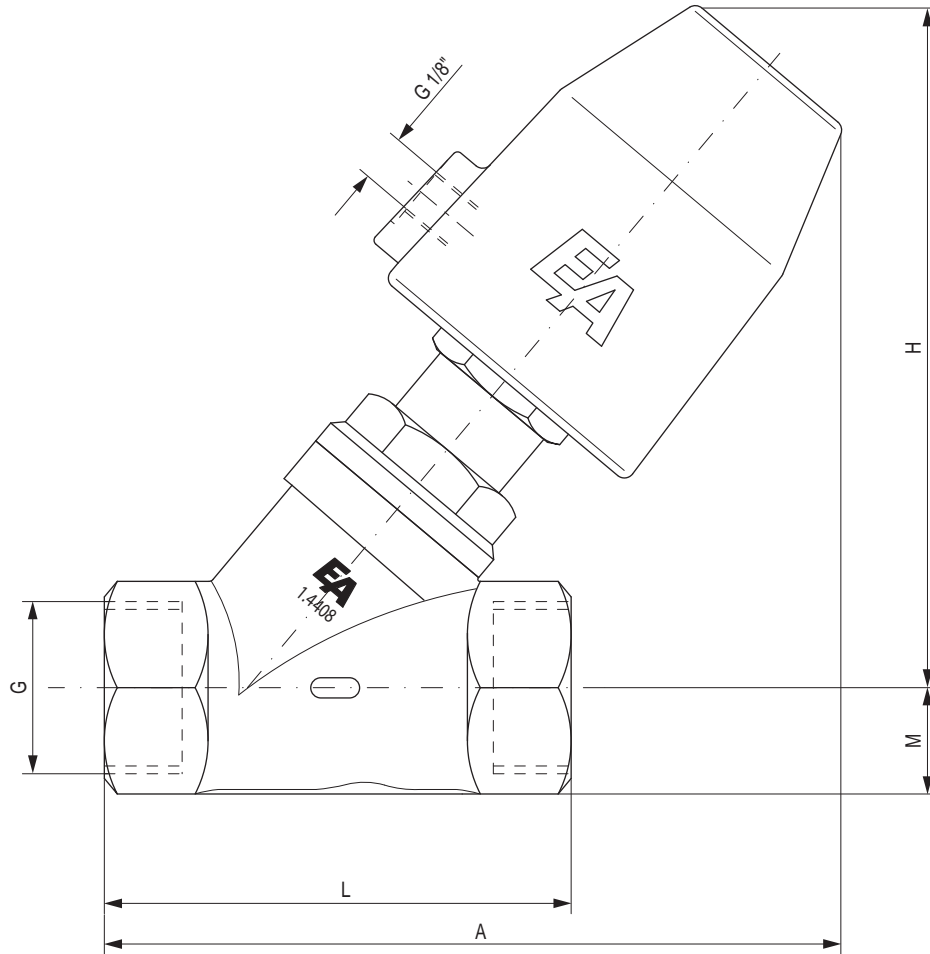

"A"- Anschweißenden DIN 3239
"A"- Butt welding DIN 3239

"L"- Anschweißenden ISO 4200
"L"- Butt welding ISO 4200

"M"- Anschweißenden DIN 11850-2
"M"- Butt welding DIN 11850-2

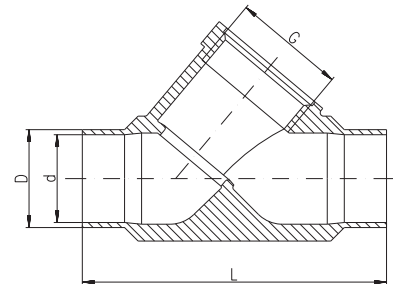
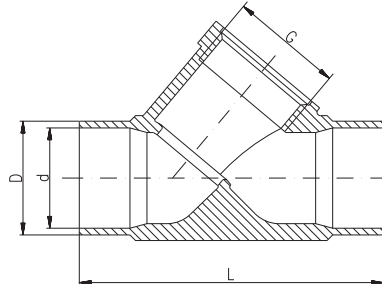
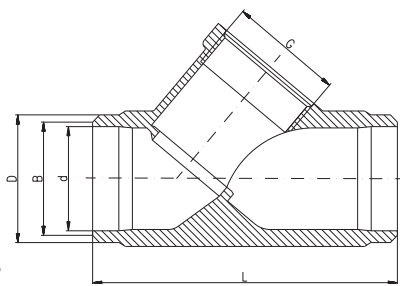

Dok-Nr.: KAT-DG(A)(L)(M)2D3-15/22 - 26.02.10 - Änderung: Steuerzylinder Ø125mm alle Version gelbsch

G	DN	DIN 3239			ISO 4200		DIN 11850-2		L	A	M ⁽¹⁾	M ⁽²⁾	H	kg
		D	B	d	D	d	D	d						
½	15	24	22	17	21,3	18,1	19	16	65	137	13,5	12,5	137	1,0
¾	20	30	28	22	26,9	23,7	23	20	75	135	16,0	15,5	130	1,1
1	25	36	34	28	33,7	29,7	29	26	90	145	20,5	18,5	136	1,4
1¼	32	45	41	35	42,4	38,4	35	32	110	158	25,0	23,0	144	1,8
1½	40	52	49	43	48,3	44,3	41	38	120	164	28,0	26,5	149	2,2
2	50	65	61	54	60,3	55,1	53	50	150	184	35,0	33,5	159	3,0

Alle Angaben für Standardausführung /
The above informations are for standard type

⁽¹⁾ Gehäuse mit Gewindeanschluß / body with thread connection

⁽²⁾ Gehäuse mit Anschweißenden / body with welded connection



Abmessungen [mm] / Dimension [mm]:

Steuerkolben Ø 63mm/
Actuator Ø 63mm

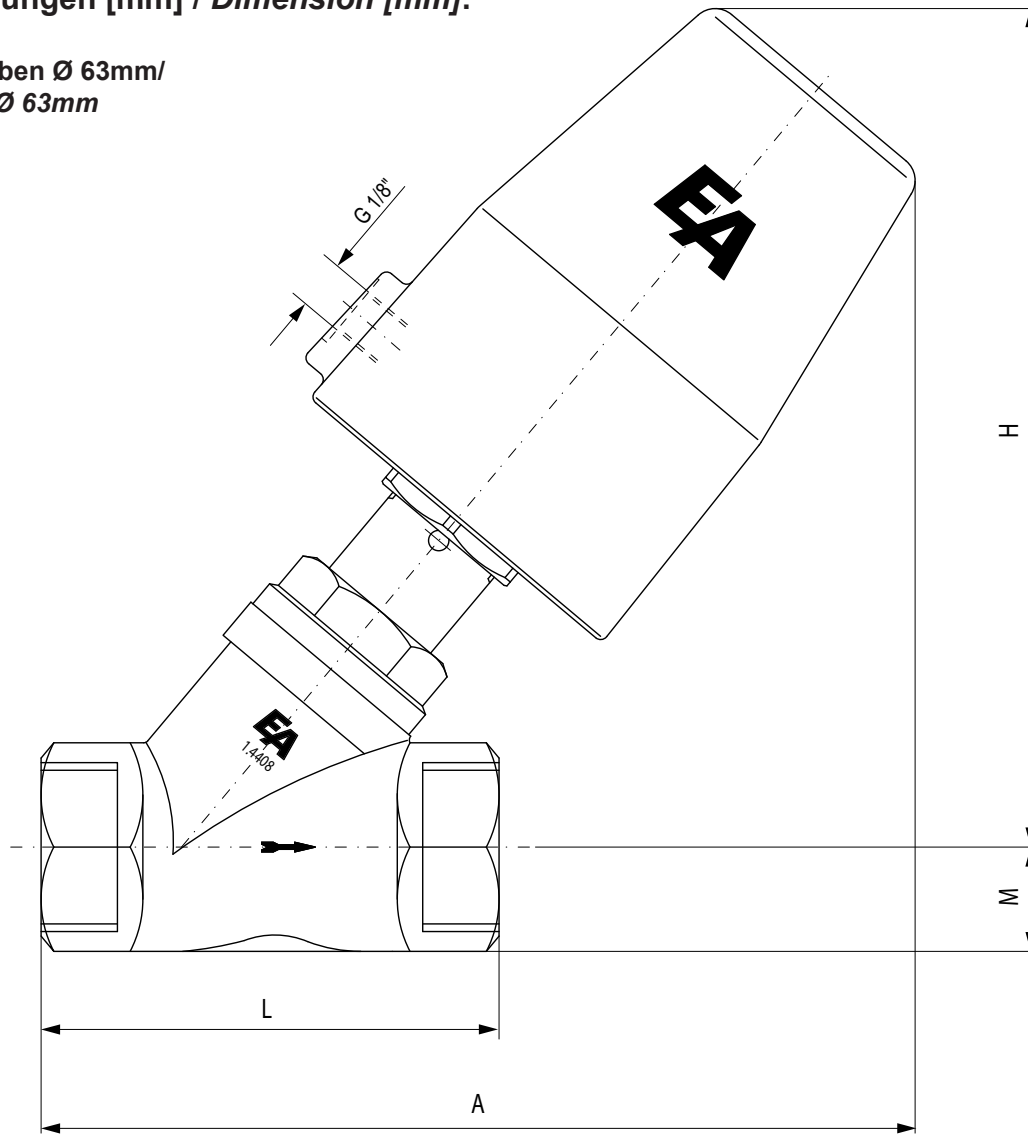

"A"- Anschweißenden DIN 3239
"A"- Butt welding DIN 3239

"L"- Anschweißenden ISO 4200
"L"- Butt welding ISO 4200

"M"- Anschweißenden DIN 11850-2
"M"- Butt welding DIN 11850-2

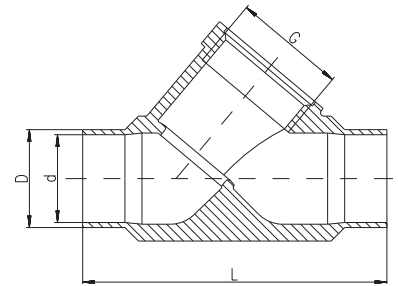
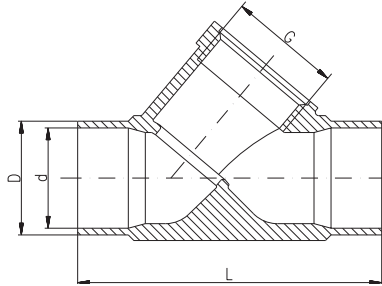
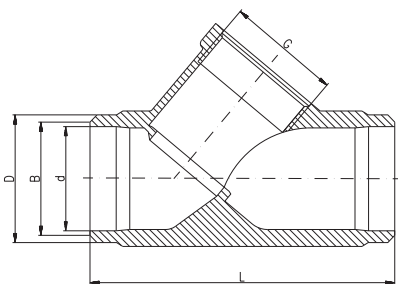

G	DN	DIN 3239			ISO 4200		DIN 11850-2		L	A	M ⁽¹⁾	M ⁽²⁾	H	kg
		D	B	d	D	d	D	d						
1	25	36	34	28	33,7	29,7	29	26	90	178	20,5	18,5	171	1,4
1¼	32	45	41	35	42,4	38,4	35	32	110	191	25,0	23,0	179	1,8
1½	40	52	49	43	48,3	44,3	41	38	120	197	28,0	26,5	184	2,2
2	50	65	61	54	60,3	55,1	53	50	150	217	35,0	33,5	194	3,0
2½	65	-	-	-	76,1	70,3	70	66	180/205*	305	42,5	42,5	278	6,5
3	80	-	-	-	88,9	83,1	85	81	200/220*	315	50,0	50,0	295	8,0

*) = Baulänge für Gehäuse mit Anschweißenden /
Face to face dimension for body with butt welding ends
Alle Angaben für Standardausführung /
The above informations are for standard type

⁽¹⁾: Gehäuse mit Gewindeanschluß /
body with thread connection
⁽²⁾: Gehäuse mit Anschweißenden /
body with welded connection



Abmessungen [mm] / Dimension [mm]:

Steuerkolben Ø 80mm/
Actuator Ø 80mm

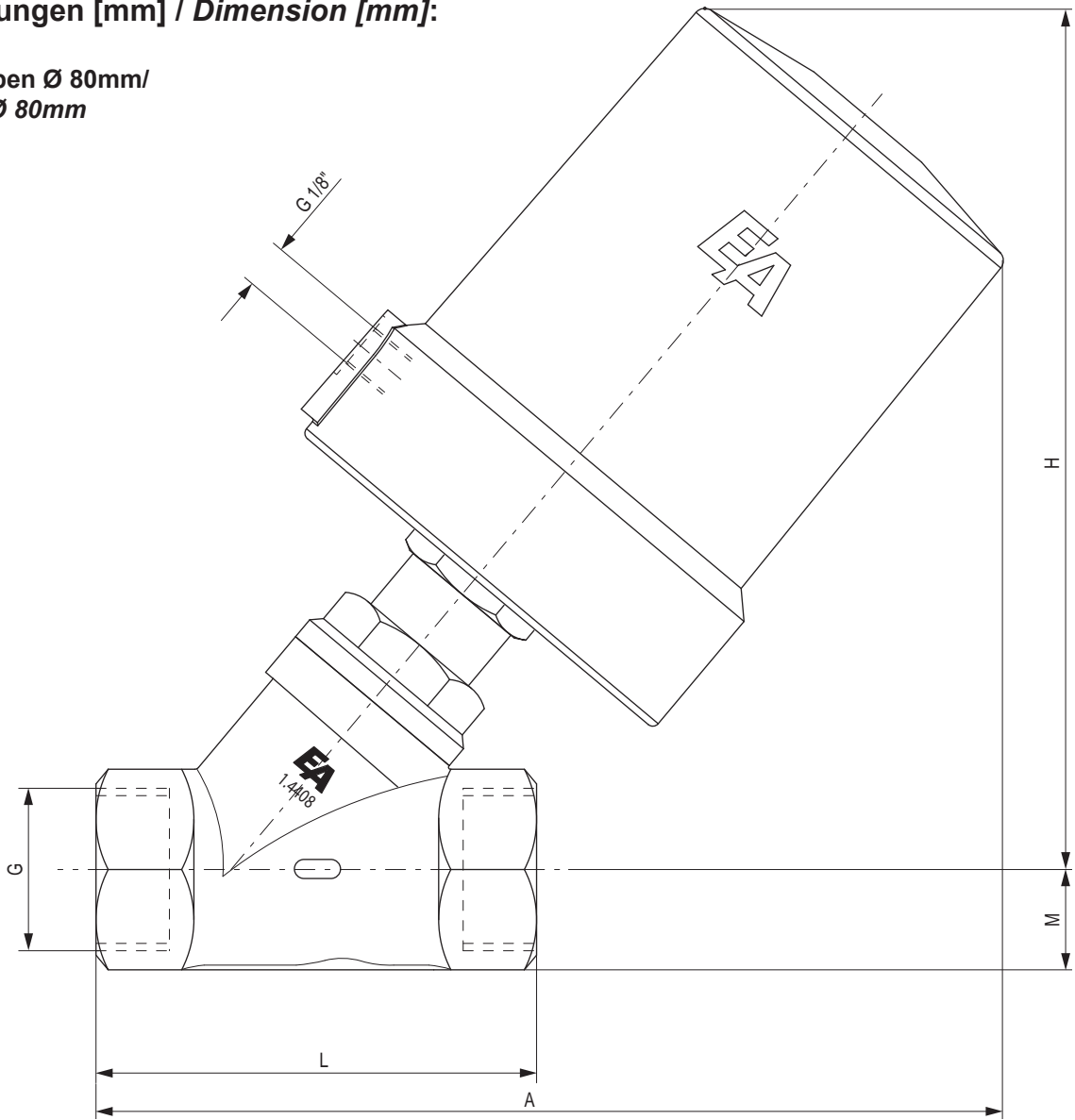

"A"- Anschweißenden DIN 3239
"A"- Butt welding DIN 3239

"L"- Anschweißenden ISO 4200
"L"- Butt welding ISO 4200

"M"- Anschweißenden DIN 11850-2
"M"- Butt welding DIN 11850-2

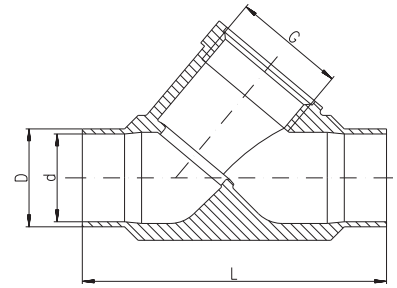
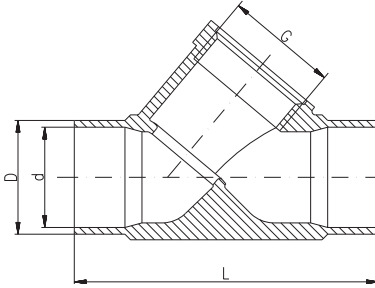
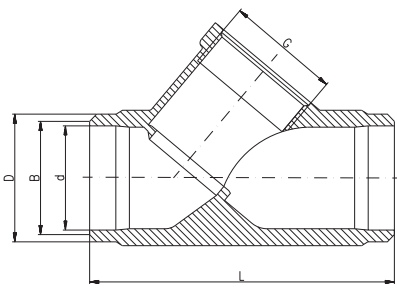

G	DN	D	DIN 3239			ISO 4200		DIN 11850-2		L	A	M ⁽¹⁾	M ⁽²⁾	H	kg
			B	d	D	d	D	d							
1	25	36	34	28	33,7	29,7	29	26	90	193	20,5	18,5	183	3,3	
1¼	32	45	41	35	42,4	38,4	35	32	110	204	25,0	23,0	192	3,5	
1½	40	52	49	43	48,3	44,3	41	38	120	210	28,0	26,5	198	4,0	
2	50	65	61	54	60,3	55,1	53	50	150	225	35,0	33,5	205	5,0	
2½	65	-	-	-	76,1	70,3	70	66	180/205*	315	42,5	42,5	298	6,5	
3	80	-	-	-	88,9	83,1	85	81	200/220*	335	50,0	50,0	305	8,0	

Dok.-Nr.: KAT-DG(A)(L)(M)2D3-17/22 - 26.02.10 - Änderung: Steuerzylinder Ø125mm alle Version gelbsch

*) = Baulänge für Gehäuse mit Anschweißenden /
Face to face dimension for body with butt welding ends
Alle Angaben für Standardausführung /
The above informations are for standard type

⁽¹⁾: Gehäuse mit Gewindeanschluß /
body with thread connection
⁽²⁾: Gehäuse mit Anschweißenden /
body with welded connection



Abmessungen [mm] / Dimension [mm]:

Steuerkolben Ø 125mm (Steuerzylinder: Edelstahl)/
Actuator Ø 125mm (pilot cylinder: stainless steel)

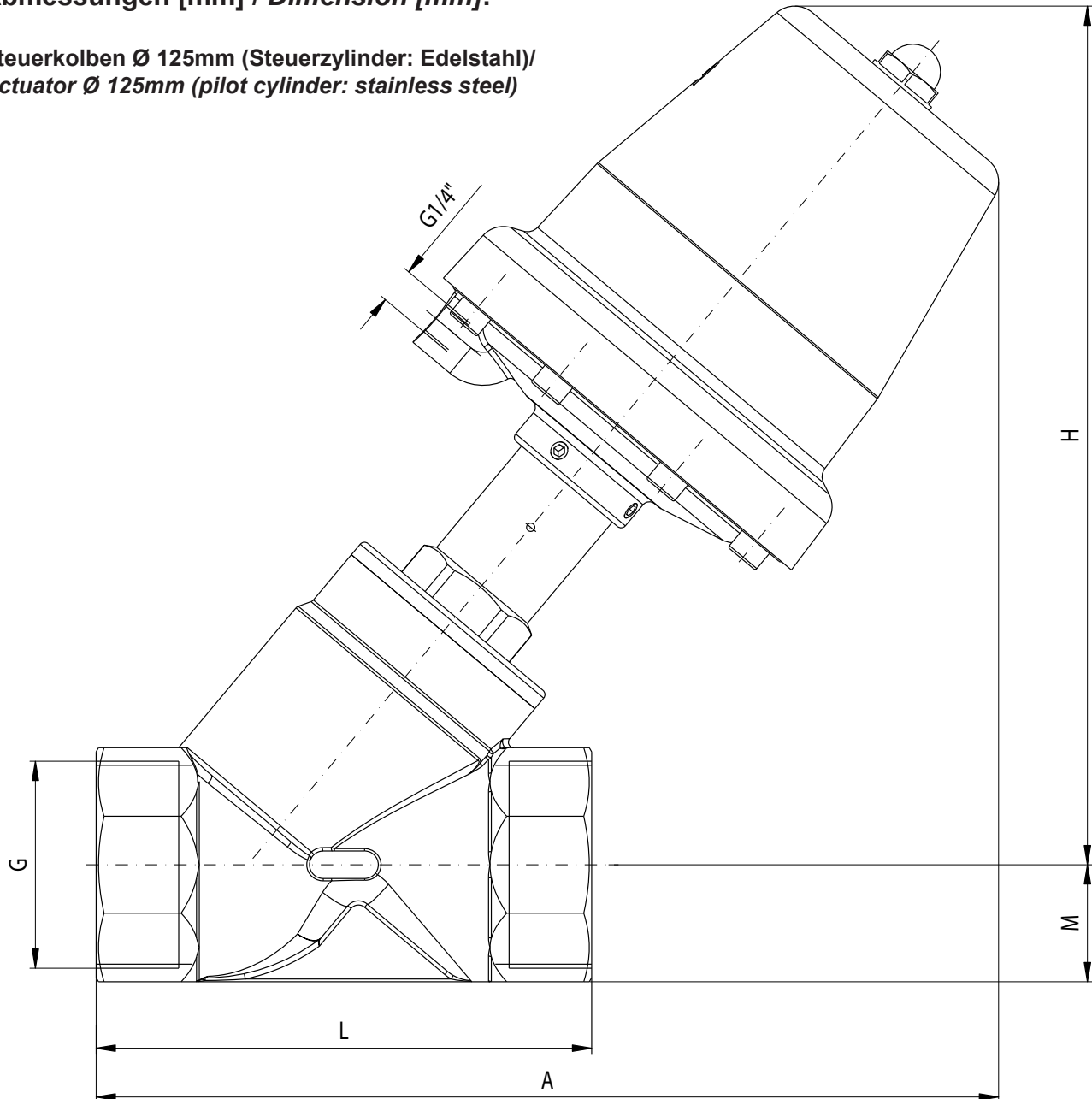

"A"- Anschweißenden DIN 3239
"A"- Butt welding DIN 3239

"L"- Anschweißenden ISO 4200
"L"- Butt welding ISO 4200

"M"- Anschweißenden DIN 11850-2
"M"- Butt welding DIN 11850-2

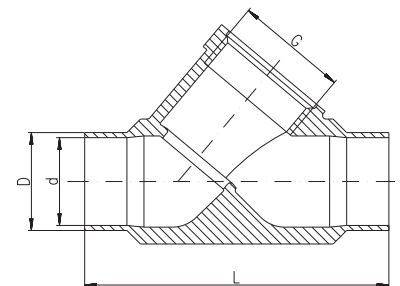
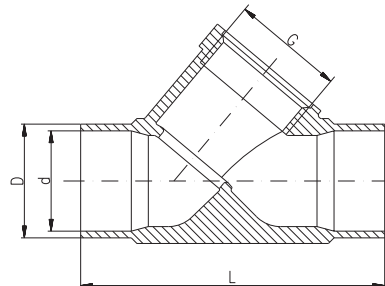
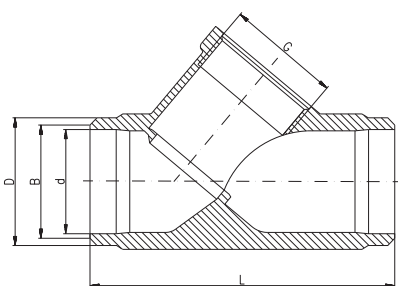

G	DN	DIN 3239			ISO 4200		DIN 11850-2		L	A	M ⁽¹⁾	M ⁽²⁾	H	kg
		D	B	d	D	d	D	d						
2	50	65	61	54	60,3	55,1	53	50	150	290	35,0	33,5	275	5,0
2½	65	-	-	-	76,1	70,3	70	66	180/205*	330/342*	42,5	42,5	315	8,7
3	80	-	-	-	88,9	83,1	85	81	200/220*	340/350*	50,0	50,0	320	

*) = Baulänge für Gehäuse mit Anschweißenden /
Face to face dimension for body with butt welding ends
Alle Angaben für Standardausführung /
The above informations are for standard type

⁽¹⁾: Gehäuse mit Gewindeanschluß /
body with thread connection
⁽²⁾: Gehäuse mit Anschweißenden /
body with welded connection



Abmessungen [mm] / Dimension [mm]:

Steuerkolben Ø 50mm/
Actuator Ø 50mm

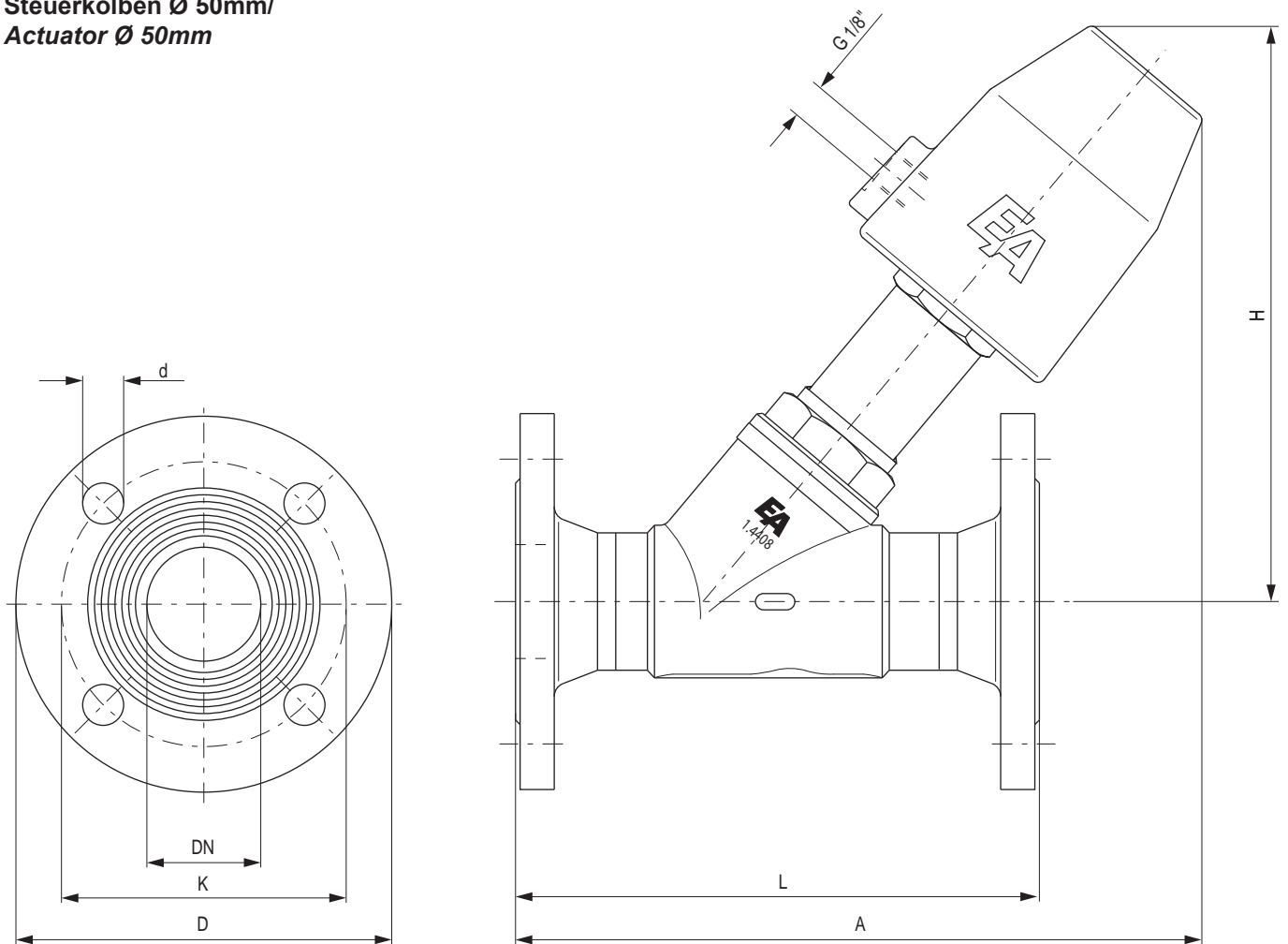

DN	L	A	H	Flansch PN 40 / flange PN 40				kg
				D	d	K	n	
15	130	190	160	95	14	65	4	1,0
20	150	200	160	105	14	75	4	1,1
25	160	205	170	115	14	85	4	1,4
32	180	210	170	140	18	100	4	1,8
40	200	215	150	150	18	110	4	2,2
50	230	245	180	165	18	125	4	3,0

Alle Angaben für Standardausführung /
The above informations are for standard type

Dok.-Nr.: KAT-DG(A)(L)(M)2D3-19/22 - 26.02.10 - Änderung: Steuerzylinder Ø125mm alle Version gelöscht



Abmessungen [mm] / Dimension [mm]:

Steuerkolben Ø 63mm/
Actuator Ø 63mm

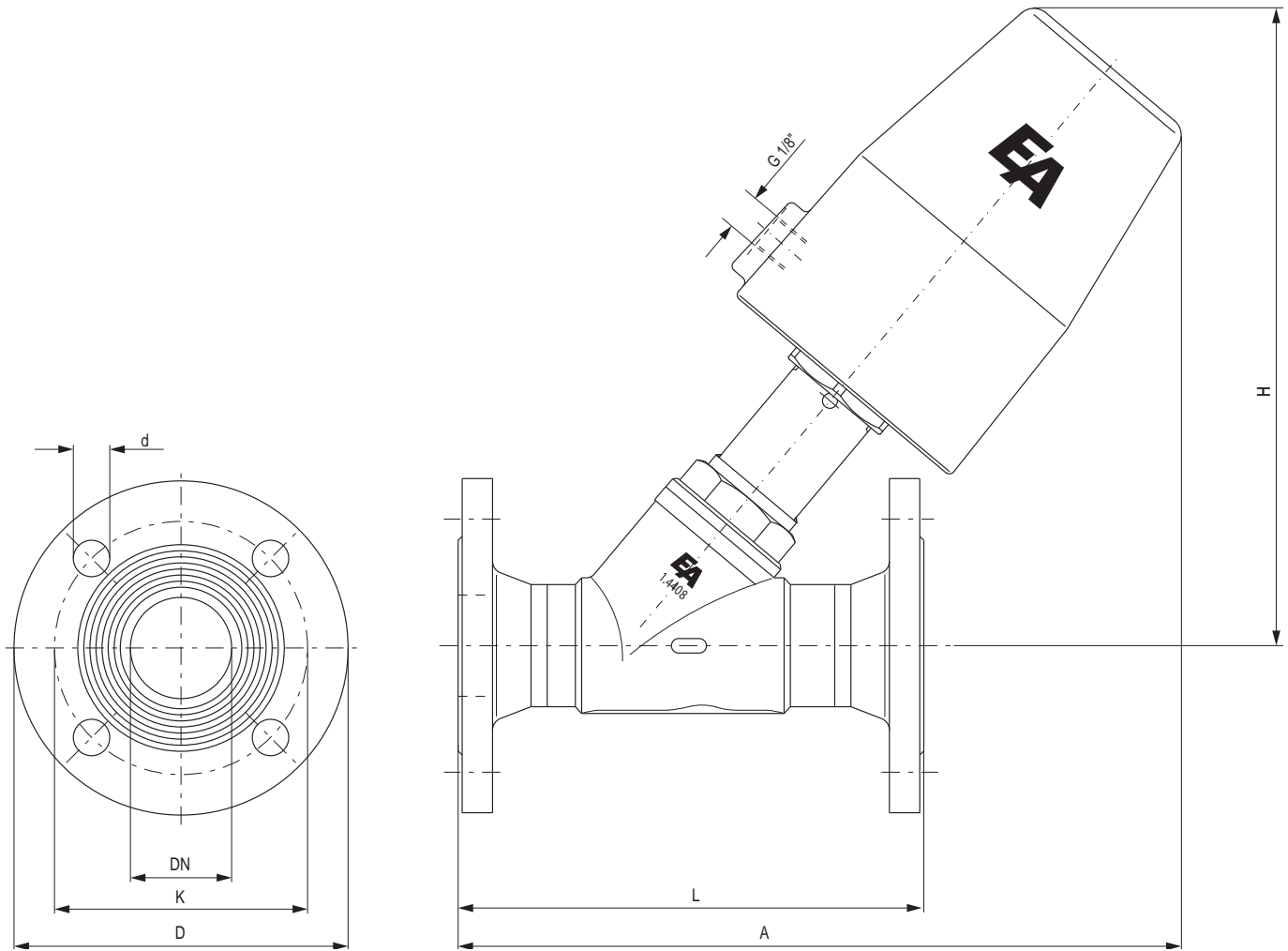

DN	L	A	H	Flansch PN 40 / flange PN 40				kg
				D	d	K	n	
25	160	238	205	115	14	85	4	1,4
32	180	243	205	140	18	100	4	1,8
40	200	248	185	150	18	110	4	2,2
50	230	278	215	165	18	125	4	3,0
65 *	290	355	285	185	18	145	4	6,5
80	310	365	355	200	18	160	8	8,0

* Flansche PN16 - DN65 werden in 4-Loch-Ausführung geliefert!
Flanges PN16 - DN65 will be delivered in 4-hole execution!

Alle Angaben für Standardausführung /
The above informations are for standard type



Abmessungen [mm] / Dimension [mm]:

Steuerkolben Ø 80mm/
Actuator Ø 80mm

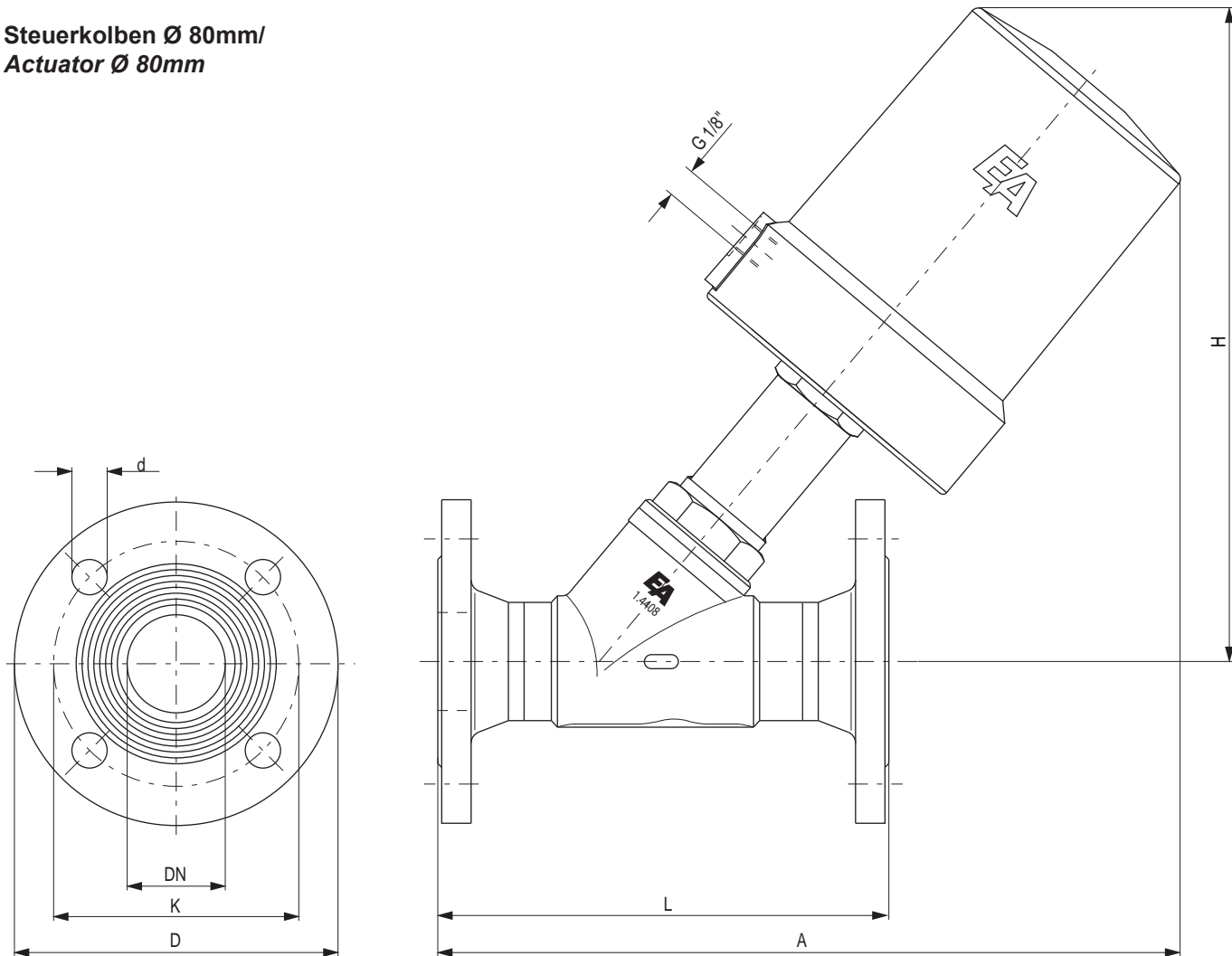

DN	L	A	H	Flansch PN 40/16 / flange PN 40/16				kg
				D	d	K	n	
25	160	255	210	115	14	85	4	3,3
32	180	265	220	140	18	100	4	3,5
40	200	280	225	150	18	110	4	4,0
50	230	300	245	165	18	125	4	5,0
65 *	290	365	295	185	18	145	4	6,5
80	310	375	375	200	18	160	8	8,0

* Flansche PN16 - DN65 werden in 4-Loch-Ausführung geliefert!
Flanges PN16 - DN65 will be delivered in 4-hole execution!

Alle Angaben für Standardausführung /
The above informations are for standard type

Dok.-Nr.: KAT-DG(A)(L)(M)2D3-2122 - 26.02.10 - Änderung: Steuerzylinder Ø125mm alle Version gelblich



Abmessungen [mm] / Dimension [mm]:

Steuerkolben Ø 125mm (Steuerzylinder: Edelstahl)
Actuator Ø 125mm (pilot cylinder: stainless steel)

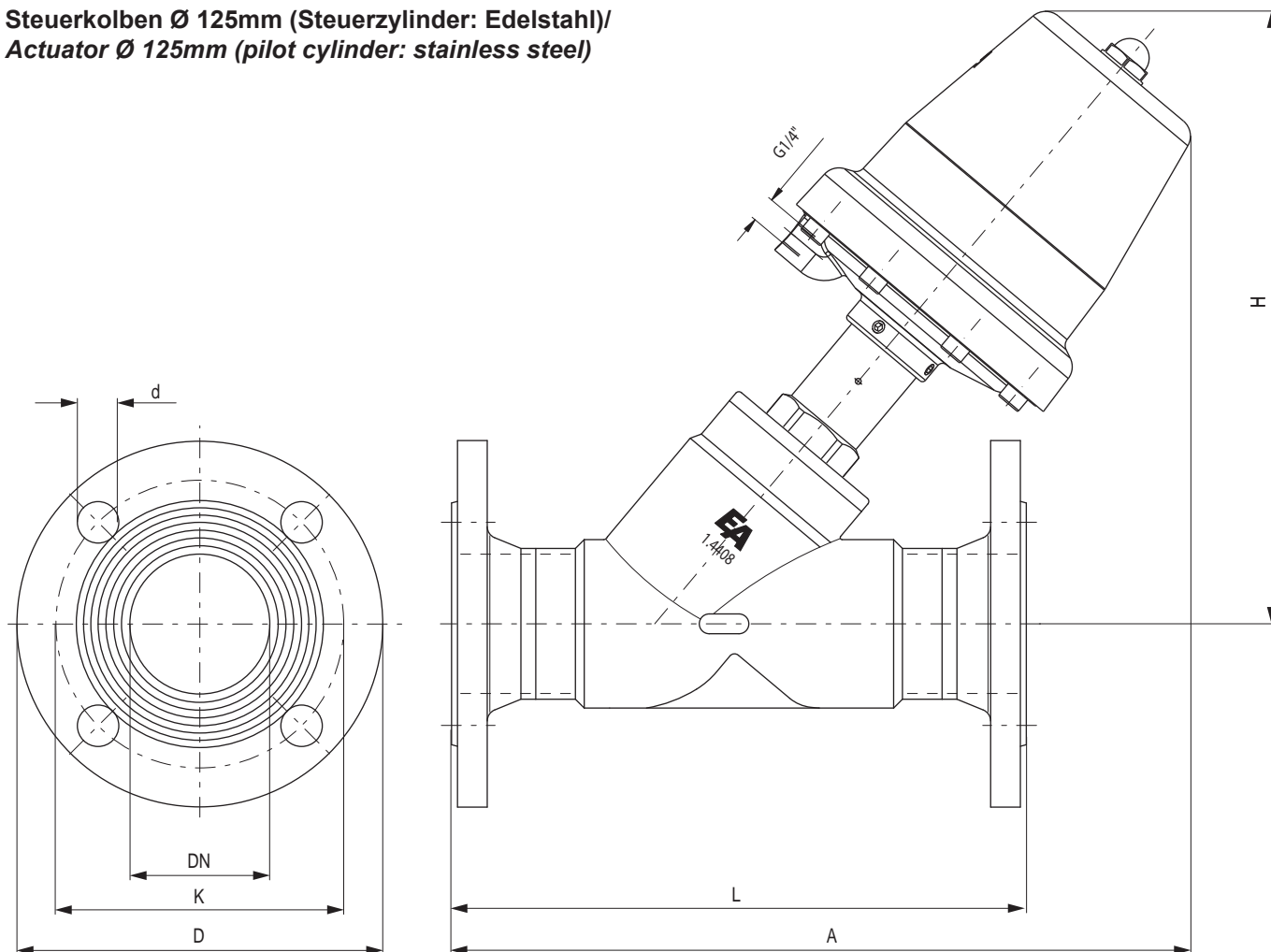

DN	L	A	H	Flansch PN16 / flange PN16				kg
				D	d	K	n	
50	230	330	275	165	18	125	4	
65*	290	380	315	185	18	145	4	
80	310	390	320	200	18	160	8	

* Flansche PN16 - DN65 werden in 4-Loch-Ausführung geliefert!
Flanges PN16 - DN65 will be delivered in 4-hole execution!

Alle Angaben für Standardausführung /
The above informations are for standard type

Hinweis

Bei den in dieser Dokumentation beschriebenen Produkten, in der von uns gelieferten Form handelt es sich um unvollständige Maschinen gemäß Artikel 2 Absatz g im Sinne der Richtlinie 2006/42/EG über Maschinen, deren Inbetriebnahme solange untersagt ist, bis festgestellt wurde, dass die Maschinen, in die die unvollständigen Maschinen eingebaut wurden, den Bestimmungen der Richtlinie 2006/42/EG über Maschinen entspricht.

Beachten Sie hierzu auch die Einbauerklärung und die Einbauanleitung.

Advice

The products described in this documentation in the conditions of our delivery are partly completed machinery according to annex 2 paragraph g of the directive 2006/42/EC on machinery, which must not be put into service until the final machinery into which it is to be incorporated has been declared in conformity with the provisions of the Directive 2006/42/EC on machinery, where appropriate.

Please take notice to the Declaration of incorporation and the assembly instruction.