



Qualität von Anfang an.

Technische Daten

BAUFORM

2-teilige Körperkonstruktion (verschraubt), mit eingeschraubtem Oberteil.

BETÄTIGUNG

Drehung des Handrads.

ANSCHLUß

Innengewinde 1/8 bis 2

BETRIEBSDRUCK*

AC1010xx(Messing) : PN 100
 AC4010xx(Stahl) : PN120 / PN 400
 AC3010xx(Edelstahl) : PN120 / PN 400

TEMPERATURBEREICH

AC1010xx: -30°C bis max. 100°C
 AC4010xx: -35°C bis max. 350°C
 AC3010xx: -35°C bis max. 200°C

WERKSTOFFE

AC1010xx (Messing)
 Gehäuse Cu Zn 39Pb3F37
 Kopfstück Messing (Ms58)
 Spindel Messing (Ms58)
 Stopfbuchsgrundring Messing (Ms58)
 Spindeldichtung PTFE
 Stopfbuchsmutter Messing (Ms58)
 Kunststoffhandrad, ab G1¼ Blech

AC4010xx (Stahl):

Gehäuse 9 S 20 K
 Kopfstück 9 S 20 K
 Spindel 1.4104
 Stopfbuchsgrundring 1.4104
 Spindeldichtung Graphit
 Stopfbuchsmutter 9 S 20 K
 Kunststoffhandrad, ab G1 Blech

AC3010xx (Edelstahl):

Gehäuse 1.4571
 Kopfstück 1.4571
 Spindel 1.4571
 Stopfbuchsgrundring 1.4571
 Spindeldichtung PTFE
 Stopfbuchsmutter 1.4571
 Kunststoffhandrad, ab G1 Blech

Specification

DESIGN

Body consists of 2 screwed parts, with screwed top.

OPERATION

Rotation of the handlewheel.

CONNECTION

Female thread 1/8 - 2

PRESSURE RANGE*

AC1010xx(Brass) : PN 100
 AC4010xx(carbon steel) : PN120 / PN 400
 AC3010xx(stainless steel) : PN120 / PN 400

TEMPERATURE RANGE

AC1010xx: -30°C up to max. 100°C
 AC4010xx: -35°C up to max. 350°C
 AC3010xx: -35°C up to max. 200°C

MATERIALS

AC1010xx (Brass)
 Body Cu Zn 39Pb3F37
 Bonnet Brass (Ms58)
 Spindle Brass (Ms58)
 Packing bottom-ring Brass (Ms58)
 Spindle seal PTFE
 Packing nut Brass (Ms58)
 Plastic handwheel, from G1¼ steel

AC4010xx (Carbon Steel):

Body 9 S 20 K
 Bonnet 9 S 20 K
 Spindle 1.4104
 Packing bottom-ring 1.4104
 Spindle seal Graphite
 Packing nut 9 S 20 K
 Plastic handwheel, from G1 steel

AC3010xx (Stainless Steel):

Body 1.4571
 Bonnet 1.4571
 Spindle 1.4571
 Packing bottom-ring 1.4571
 Spindle seal PTFE
 Packing nut 1.4571
 Plastic handwheel, from G1 steel

Artikel:
AC

Nadelventil
PN 100 / PN 400

Messing
Stahl
Edelstahl



Type:
AC

Needle-valve
PN 100 / PN 400

Brass
Carbon Steel
Stainless Steel



Alle Angaben sind freibleibend und unverbindlich!

The above information is intended for guidance only and the company reserves the right to change any data herein without prior notice!

* = Erforderliche Druckabschläge / Required Pressure Reduction

Temperatur / Temperature	50°C	100°C	200°C	300°C	400°C
Druckabschläge / Pressure Reduction	6%	15%	37%	60%	84%



Artikel- u. Bestellangaben: z.B. AC301025

= Nadelventil, Edelstahl, Handrad, Innengewinde, 1"

1.+ 2. Stelle Produkt	3.+ 4. Stelle Werkstoffe Gehäuse	5. Stelle Betätigung	6. Stelle Zusatzausstattung	7.+ 8. Stelle Anschlußgröße
AC = Nadelventil	10 = Messing 30 = Edelstahl 40 = Stahl	1 = Handhebel	0 = ohne	20 = 1/8" 21 = 1/4" 22 = 3/8" 23 = 1/2" 24 = 3/4" 25 = 1" 26 = 1 1/4" 27 = 1 1/2" 28 = 2"

Ordering example: e.g. AC301025

= Needle-valve, Stainless Steel, handle wheel, female thread, 1"

1.+ 2. Digit Product	3.+ 4. Digit Material Body	5. Digit Operation	6. Digit Options	7.+ 8. Digit Connection size
AC = Needle-valve	10 = Brass 30 = Stainless Steel 40 = Carbon Steel	1 = Handwheel	0 = no options	20 = 1/8" 21 = 1/4" 22 = 3/8" 23 = 1/2" 24 = 3/4" 25 = 1" 26 = 1 1/4" 27 = 1 1/2" 28 = 2"

Abmessungen / Dimension :

AC1010xx (Messing / brass):

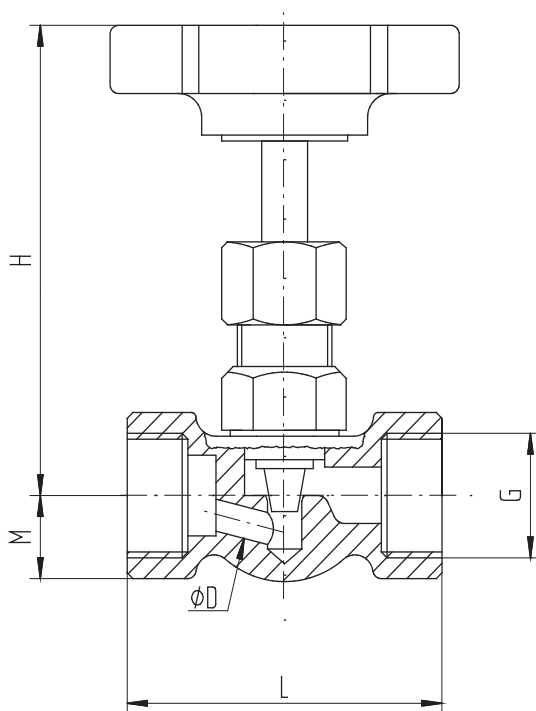

G	["]	1/8	1/4	3/8	1/2	3/4	1	1 1/4	1 1/2	2
D	[mm]	4	5	6	6,5	9	11	13	15	15
L	[mm]	50	50	50	55	67	75	110	110	122
H	[mm]	78	78	78	78	90	90	110	110	120
M	[mm]	12,0	12,0	12,0	14,0	18,0	23,0	31,5	33,0	40,0
kv	[m³/h]	0,24	0,48	0,6	0,66	1,08	1,62	3,0	3,6	3,6
PN	[bar]	100	100	100	100	100	100	100	100	100
	[kg]	0,25	0,25	0,24	0,26	0,48	0,65	1,80	1,95	3,34

Kv-Wert [m³/h], Δp = 1 bar

Flow rate [m³/h], Δp = 1 bar



AC4010xx (Stahl / carbon steel):
AC3010xx (Edelstahl / stainless steel):

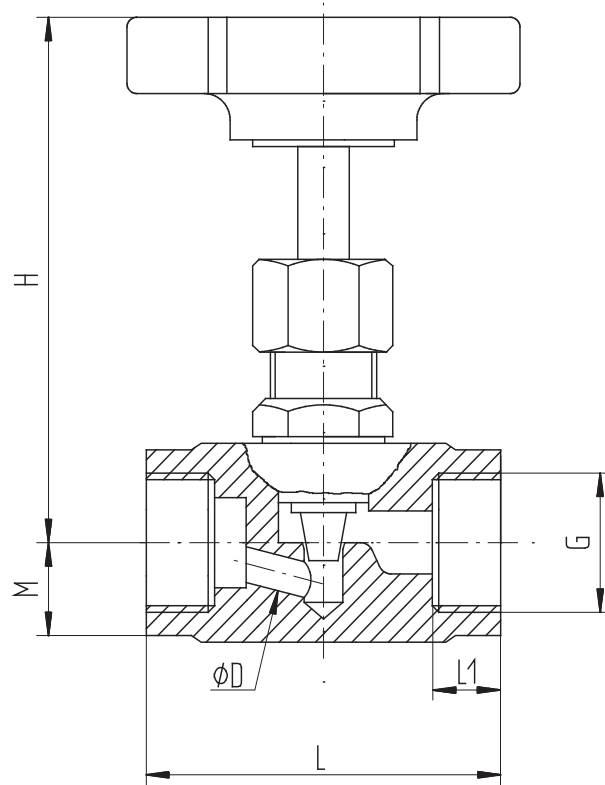

AC4010xx (Stahl / carbon steel):

G	["]	1/8	1/4	3/8	1/2	3/4	1	1 1/4	1 1/2	2
D	[mm]	4	5	6	7	9	12	15	22	22
L	[mm]	45	50	55	60	75	100	110	130	130
L1	[mm]	11	14	15	16	18	22	26	28	28
H	[mm]	72	72	72	77	95	110	145	145	145
M	[mm]	12,5	12,5	12,5	15,0	17,5	22,5	30,0	35,0	35,0
kv	[m³/h]	0,24	0,48	0,6	0,74	1,35	1,66	3,10	5,56	5,56
PN	[bar]	400	400	400	400	200	200	160	120	120
	[kg]	0,32	0,31	0,31	0,41	0,72	1,46	3,17	4,70	3,73

Kv-Wert [m³/h], Δp = 1 bar
 Flow rate [m³/h], Δp = 1 bar

AC3010xx (Edelstahl / stainless steel):

G	["]	1/8	1/4	3/8	1/2	3/4	1	1 1/4	1 1/2	2
D	[mm]	4	5	6	7	9	12	15	22	22
L	[mm]	45	50	55	60	75	100	110	130	130
L1	[mm]	11	14	15	16	18	22	26	28	28
H	[mm]	72	72	72	77	95	110	145	145	145
M	[mm]	12,5	12,5	12,5	15,0	17,5	22,5	30,0	35,0	35,0
kv	[m³/h]	0,24	0,48	0,6	0,74	1,35	1,66	3,10	5,56	5,56
PN	[bar]	400	400	400	400	200	200	160	120	120
	[kg]	0,31	0,31	0,32	0,41	0,72	1,51	3,10	4,25	3,83

Kv-Wert [m³/h], Δp = 1 bar
 Flow rate [m³/h], Δp = 1 bar

Dok-Nr.: KAT-AC-3/3 - 01/2012 - Änderungen: Werkstoff Spindel/dichtung AC1010xx

Hinweis

Bei den in dieser Dokumentation beschriebenen Produkten, in der von uns gelieferten Form, handelt es sich weder um Maschinen gemäß Artikel 2 Absatz a noch um unvollständige Maschinen gemäß Artikel 2 Absatz g im Sinne der Richtlinie 2006/42/EG über Maschinen.

Advice

The products described in this documentation in the conditions of our delivery are no machinery according to annex 2 paragraph a respectively no partly completed machinery according to annex 2 paragraph g of the directive 2006/42/EC on machinery.

