



Qualität von Anfang an.

Original Operating Manual Safety Valves

SV
GV
NG



© by **END-Armaturen GmbH & Co. KG**

All rights reserved.

END-Armaturen GmbH & Co. KG claims copyright over this documentation.

This documentation may neither be altered, expanded, reproduced nor passed to third parties without the written agreement of **END-Armaturen GmbH & Co. KG**. This restriction also applies to the corresponding drawings.

END-Armaturen GmbH & Co. KG has the right to change parts of the valves and armatures at any time without prior or direct notice to the client. The contents of this publication are subject to change without notice.

This publication has been written with great care.

However, **END-Armaturen GmbH & Co. KG** cannot be held responsible, either for any errors occurring in this publication or for their consequences.

The products are specified by the statements in this documentation; no assurance or the properties is given.

END-Armaturen GmbH & Co. KG

Oberbecksener Straße 78

D-32547 Bad Oeynhausen

Telefon: 05731 / 7900 - 0

Telefax: 05731 / 7900 - 199

Internet: <http://www.end.de>

E-Mail: post@end.de

Edition: 02/11

Contents

1	Foreword	5
2	General advice	6
2.1	Validity	6
2.2	Inward monitoring	6
2.3	Complaints	6
2.4	Warranty	6
2.5	Symbols and their signification	7
3	Safety advice	8
3.1	Personal advice	8
3.1.1	Safety advices for mounting	8
3.1.2	Safety advice for adjustment / starting	9
3.1.3	Safety advice for maintaining / repairing	9
3.2	Device safety	10
4	Identification of Safety Valves	11
5	Safety Valves	12
5.1	General	12
5.2	Corresponding use	12
5.3	Operation	12
5.3.1	Advice for storage and starting of safety valves	12
5.4	Mounting / Disassembly	13
5.4.1.	Inlet pipe	13
5.4.2.	Blow-off pipe	14
5.4.3.	Open discharge Safety Valves	15
5.4.4.	Condensate diversion	15
5.4.5	Mounting with threaded connection	15
5.4.6	Mounting with flanged connection	15
5.4.7	Disassembly	16
5.5.	Commissioning	16
5.5.1	Safety Valve with lifting device	17
5.5.2	Safety Valve without lifting device	17
5.6	Maintenance	17
5.6.1	Test intervals	17
5.6.2	Regular releasing of the safety valve	18
5.6.3	Leaks	18
6	Index	23

1 Foreword

Dear customer,
Dear assembler / user,

these operation and installation manuals are intended to give you the knowledge, which is necessary for you to be able to carry out the mounting and adjustment of the safety valves rapidly and correctly.



Please read these instructions carefully and pay particular attention to the advice and warning notes.

Only instructed and qualified mechanic should mount, adjust or maintain the safety valves.

If you have any questions in relation to the safety valves we shall be pleased to answer them. The telephone number will be found on the inside cover of these operation and installation manual.

Yours
END-Armaturen GmbH & Co. KG

2 General advice

2.1 Validity

This mounting and installation manual is valid for the standard version of the safety valves.

2.2 Inward monitoring

Please check

- directly after delivery the safety valves for any transport damages and deficiencies
- with reference to the accompanying delivery note the number of parts.

Do not leave any parts in the package.

2.3 Complaints

Claims for replacement or goods which relate to transport damage can only be considered valid if the delivery company is notified without delay.

In case of returns (because of transport damage / repairs), please make a damage protocol and send the parts back to the manufacturer, if possible in the original packaging.

In case of a return, please mention the following:

- Name and address of the consignee
- Stock-/ ordering-/ article-number
- Description of the defect

2.4 Warranty

For our ball valves we give a guarantee period in accordance with the sales contract. The end of the normal duration of life of the wearing parts represents no defect.

The warranty and guarantee rules of **END-Armaturen GmbH & Co. KG** are applicable.

2.5 Symbols and their signification



Paragraphs which are identified with this symbol contain very important advices; this also includes advices for averting health risks. Observe these paragraphs without fail!



Paragraphs which are identified with this symbol contain very important advices, this also includes how to avoid damage to property. Observe these paragraphs without fail!



This symbol indicates paragraphs which contain comments / advices or tips.



This spanner identifies the description of actions which you should carry out.

3 Safety advice

Depending on the technical circumstances and the time under and at which the armatures and valves are mounted, adjusted and commissioned, you must take into account particular safety aspects in each case!

If, for example, a pneumatic actuator works a slide in an operational chemical plant, the potential hazards of commissioning have another dimension from that when this is only being carried out for test purposes in a „dry“ part of the plant in the assembly room!

Since we do not know the circumstances at the time of the mounting/adjustment/commissioning, you may find advices on hazards in the following descriptions which are not relevant to you.

Please observe (only) the advices which applies to your situation!

3.1 Personal advice

3.1.1 Safety advices for mounting



We wish to point out expressly that the mounting, adjusting and at accessories the pneumatically and electrical installation of the armatures and valves must be carried out by trained specialist personnel having mechanical, pneumatically and electrical knowledge!



Secure that the machine / plant come up to the Machinery Directive after the mounting and installing of the armatures and valves.



**Switch off all the devices / machines / plant affected by mounting or repair.
If appropriate, isolate the devices / machines / plant from the mains.**



Check (for example in chemical plants) whether the switching off of devices / machines / plant will cause potential danger.



If appropriate, in the event of a fault in the armature / valve (in a plant which is in operation) inform the shift foreman / safety engineer or the works manager without delay about the fault, in order, for example, to avoid an outflow / overflow of chemicals or the discharge of gases in good time by means of suitable measures!



Before mounting or repairing, remove the pressure from pneumatic / hydraulic devices / machines / plant.



If necessary, set up warning signs in order to prevent the inadvertent starting up of the devices / machines / plant.



Observe the respective relevant professional safety and accident prevention regulations when carrying out the mounting / repair work.



Check the correct functioning of the safety equipment (for example the emergency push off buttons/ safety valves, etc)!

3.1.2 Safety advice for adjustment / starting



As a result of the starting (pneumatic, electric or by hand) of the armatures and valves the flow of gases, steam, liquids, etc. may be enabled or interrupted! Satisfy yourself that, as a result of the starting or the test adjustment no potential hazards will be produced for the personnel or the environment!



If necessary, set up warning signs in order to prevent the inadvertent starting up or shutting down of the device / machine / plant.!



By ending the adjustment check the correct function of the armature.



Check the right function of all safety devices (for example emergency push off buttons / safety valves)!



Carry out the starting and the adjustments only in accordance with the instructions described in this documentation!

3.1.3 Safety advice for maintaining / repairing



Do not carry out any maintenances / repairs if the armature will be under pressure.

Before disassembling or a armature or valve some essential points should be clarified!

- Will the armature/valve to be disassembled be replaced by another immediately?
- If appropriate, does the production process of the plant needed to be stopped?
- Is it necessary to inform specific personnel about the disassembly?



If necessary, inform the shift foreman/ safety engineer or the manager about the maintenance or repair without delay in order, for example, to avoid an outflow/ overflow of chemicals or a discharge of gases in good time by means of suitable measures!



Observe that some valves / armatures are able to enclose the pressured medium e.g. the ball in the ball valve. You have to relieve the pressure in the pipes in which the armature/valve is mounted.



Switch off pilot pressure and the power supply and relieve the pressure in the pipes.



If necessary, set up warning signs in order to prevent the inadvertent starting up or shutting down of the device / machine / plant.!



In case of defect in the armature/valve make contact to the supplier. The telephone number will be found on the back cover of these mounting and installation manual.



If you ascertain a damage of the armature/valve, isolate the device from the mains. Please observe the safety advices.



Do not mount, start or adjust the armature/valve if itself, the pipes or a mounted actuator will be damaged.



After the maintenance or repair check the right function of the armature/valve and the tightness of the pipe connections.

3.2 Device safety

The armatures/valves

- are quality products which are produced in accordance to the recognized industrial regulations.
- left the manufacturer`s work in a perfect safety condition.



In order to maintain this condition, as installer / user you must carry out your task in accordance with the description in these instructions, technically correctly and with the greatest possible precision .

We assume, as a trained specialist you are having mechanical and electrical knowledge!



Satisfy yourself that the armatures/vales will only be used within their admissible limiting value (see the technical data) .

The armatures/valves must be used only for a purpose corresponding to their construction!



The armatures/valves must be used within the values specified in the technical data!

The operating of the armature/valve outside the nominal temperature range could destroy the sealing and the bearings.



The operating of the armatures/valves outside the nominal pressure range could destroy the inner parts and the body.

Never remove a cap or a other component part if the armature/valve will be under pressure.



Do not mount, start or adjust the armature/valve if itself, the pipes or a mounted actuator will be damaged.



After the maintenance or repair check the right function of the armature/valve and the tightness of the pipe connections.



Also check the function of the accessories e.g. actuators, limit switches, etc.

4 Identification of Safety Valves

The safety valves will be provided with a name-plate (identification, which permits a definite identification of the safety valves and shows the most important technical data to you. The name-plate should not be displaced or changed.

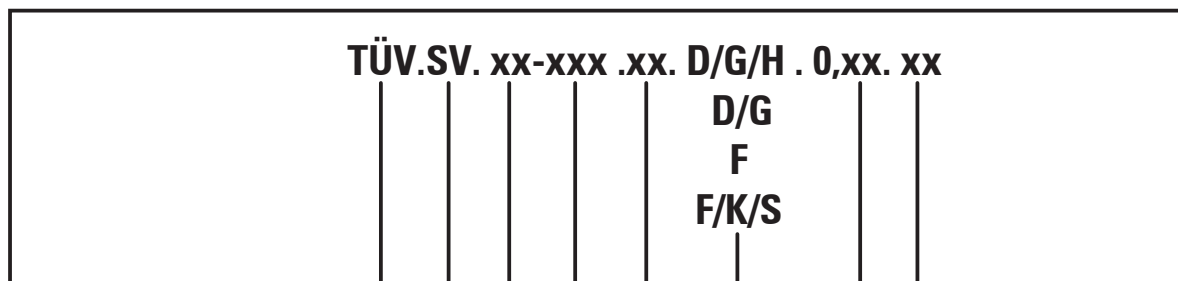
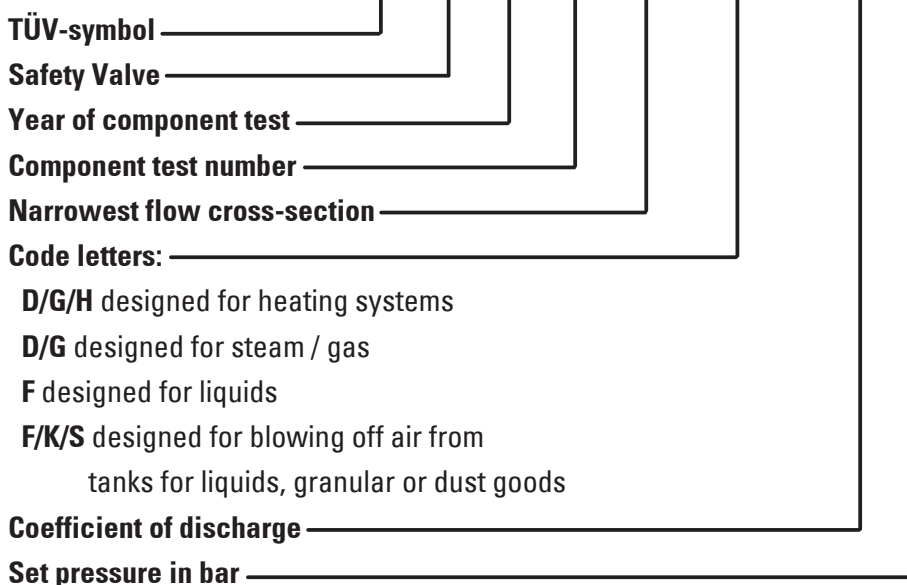

Fig. 4.1 - Identification



The safety valves will always be set by the manufacturer.

5 Safety Valves

5.1 General

Before you are mount, adjust, operate or disassemble a safety valve you have to read



→ Safety advices

If you have not read the safety advices until now, read this important advices now and turn back to this point..

5.2 Corresponding use

Safety valves have to protect pipes and tanks for inadmissible over pressure. Safety valves represented the final safety device for pipe and tanks. Safety valves must be able to prevent tanks and pipes from inadmissible over pressure, if all the other control and safety devices would break down. To secure the function of a safety valve, safety valves required particular attention by mounting and maintaining.



A safety valve is a part of equipment with safety function for the protection of pressure devices in the case of exceeding the permissible limits and thus is governed by the directive 97/23/EC of the European Parliament and of the Council ("Regulation for Pressure Devices") Article 1 Section 2.1.3.



It should only be used clean liquids and gases on which the material of the safety valve will be resistant. Pollution and using outside the nominal pressure and/or the nominal temperature range should causes damages on the safety valve especially on the seals.



At non-neutral media and media which do not tread out into the environment and also applications with a back pressure at the outlet port safety valves with bellows must be chosen.

5.3 Operation

Safety valves do not need any special operation. **But the ventilation should be operated in periodical turns.** (see chapter 5.6. „maintenance“).

5.3.1 Advice for storage and starting of safety valves

After transport and storage for some time at armatures with a formerly adjusted action pressure a delayed opening at the first time will be normal. This effect causes by the pasting up seat and cone of a valve. This will be happen at sealing areas metal / elastomer and also at sealing areas metal / metal.

After mounting the valve the sealing areas will be loosen by actuating the ventilation knob / lever and feeding the valve with compressed air and increasing the pressure range above the action pressure.

After this procedure the armature will be serviceable with the formerly adjusted action pressure in consideration for the permitted increasing pressure / closing pressure.

5.4 Mounting / Disassembly



Safety valves are high-grade armatures, which will be handle with great care. The sealing areas at the seat and the cones are hardened resp. tempered and abraded. The safety valve will be damage by inexpert handling. Therefore observe the following notes:

- In- and outlet port have to been close for delivery.
- Do not drop the safety valves.
- You have to avoid the insert or pollution during the mounting or during working.
- The tightness of the safety valve could be impaired by using hemp, PTFE- ribbon or something similar like that.
- If the safety valve will be painted you have to observe that no sliding part will be come into contact with the paint.



The hole system has to be rinsed before installation of the valve. If the plant should not be sufficiently clean in the case of an appropriate assembly, the valve may be leaky already upon first response.



The assembly of the threaded valves should be carried through without using hemp or PTFE- tape. Metal sealing rings are to be preferred.



Safety valves are to be installed always in a vertical direction, while taking into account the flow direction, that is with spring bonnet standing upright.



To ensure a satisfactory operation of the safety valves they must be installed in such a way that the safety valve is not exposed to any impermissible static, dynamic or thermal loads.



It is not permitted to have the possibility to make safety valves ineffective by blocking devices, neither upstream nor downstream of the valve.

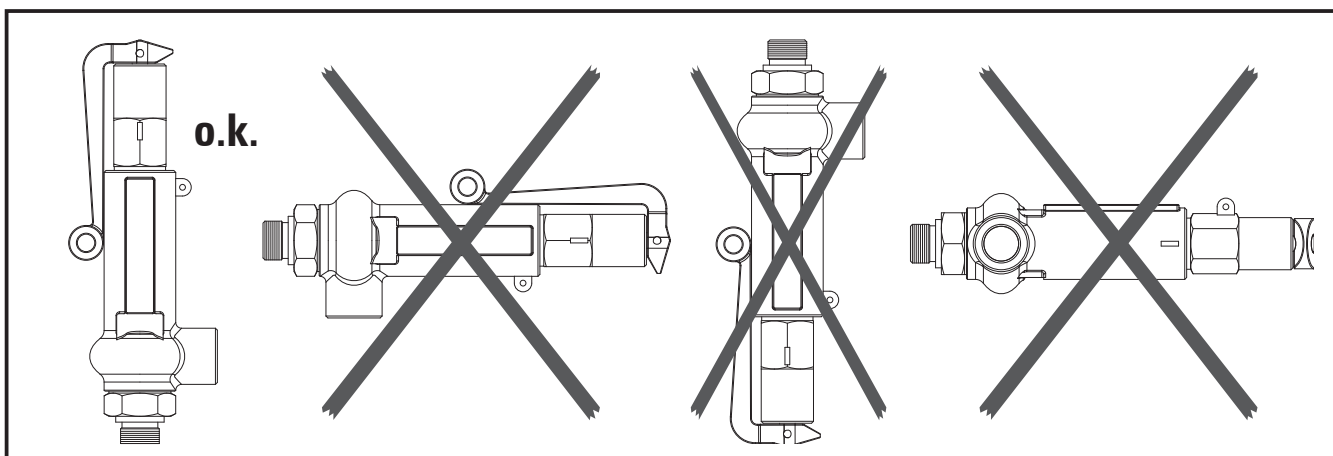

Fig.4.1 - Safety Valves, Installation (Fig. shows Art. NG301023 with head „A“)

5.4.1. Inlet pipe



The feed nozzle for the valve must be as short as possible and must have at least the same nominal width as the valve.



The pressure loss in the inlet pipe of the safety valves should not exceed 3% of the set pressure.

5.4.2. Blow-off pipe



Suitable protective measures should be taken at the installation point in the case of any safety valves posing a direct or indirect risk to persons or the environment as a result of discharge of the operating medium. Precautions must also be taken against fumes escaping through the relief vents in the spring cap.



Blow-off pipe for vapours and gases are to be installed in a rising position, for liquids in a falling position.



The blow-off pipe of the safety valves must be designed to ensure that the required mass flow can be discharged during the blowing-off process. The cross section should be equal at least as the feed-out cross section of the safety valve.

Inside the blow-off pipe the counter pressure of max. 10% of the set pressure should not be exceeded.



Precautions must be taken by means of suitable devices to ensure that foreign bodies or rain water can not penetrate into the blow-off pipe.



The discharging of the blow-off pipe must not present a risk. Risks caused by emerging fluid are to be prevented by suitable measures.

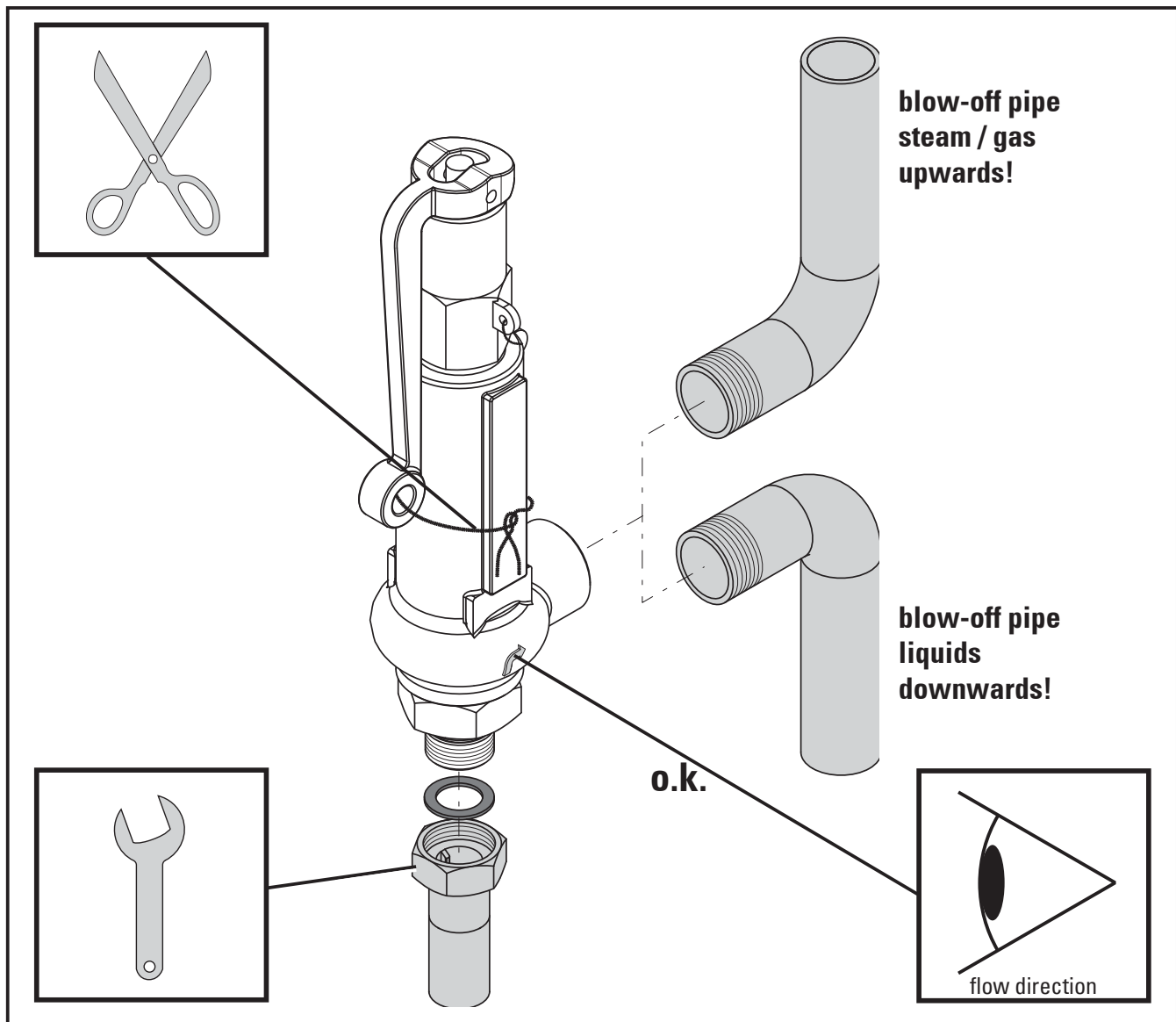

Fig. 4.2 - Safety Valves, Mounting with threaded connection (Fig. shows Art. NG301023 with head „A“)

5.4.3. Open discharge Safety Valves



The spring bonnet of the open discharge safety Valve has to be protected against pollution.



In case of blowing-off by a open discharge safety valve the operating medium will flow off through the spring bonnet. Therefore open discharge safety will only be used for non-toxic and non-flamable media.

Appropriate protection devices must be installed to protect people or the environment against hazards.

5.4.4. Condensate diversion



Any fluid or condensate is not permitted to remain in the safety valve housing since the functioning of the safety valve is impaired as a consequence.



The discharging of the condensate is usually effected via the blowing off pipe. At the lowest point a draining tube with sufficient dimensions must be installed.



Hazard-free removal of the condensate or medium discharge must be ensured. The body, pipes and silencers must be protected against freezing.

5.4.5 Mounting with threaded connection



Before lay on sealing compounds, check the hardly screwing by the pipes into the valve body.



The assembly of the threaded connection should be carried out by using metal sealing rings.



Screw the pipes into the connection ends of the safety valve.



Check the tightness of all connections.

5.4.6 Mounting with flanged connection



In the following description we assume that you have mounted the flanges at the end of the pipes and the safety valve (welded flanges) and they are cooled down.



Insert the safety valve and the flange seals between the flanges.



Align the flange boring and put fit screws through the boring.



Put fit nuts onto the screws and tighten them equally and crosswise. Observe the max. torque of the screws.



Check the tightness of all connections.

5.4.7 Disassembly

Before you disassemble the safety valve you have to read the



→ Safety advice

If you have not read the safety advices until now, read this important advices now and turn back to this point.



Prior to the disassembly of a safety valve, the device is to be made unpressurized.



Residues of fluid in a safety valve or the spring bonnet bear a great risk of burning and poisoning. Prior to the disassembly of a safety valve from the device, it must be determined which fluid might be contained in the safety valve, and corresponding safety measures have to be taken.

5.5. Commissioning



After transportation and prolonged storage of the safety valves with a pre-set reaction pressure it is possible that there will be a delayed initial opening due to what is called a sticky effect of the seat and the cone of the safety valve.



After the valve has been installed the sealing surfaces are separated from each other through an increased pressurization above the release pressure as proper as well as through the activation of the release of the sealing surfaces. Subsequently, the safety valve is again fully functioning with the pre-set reaction pressure, taking into account the permissible pressure increase / closing pressure.

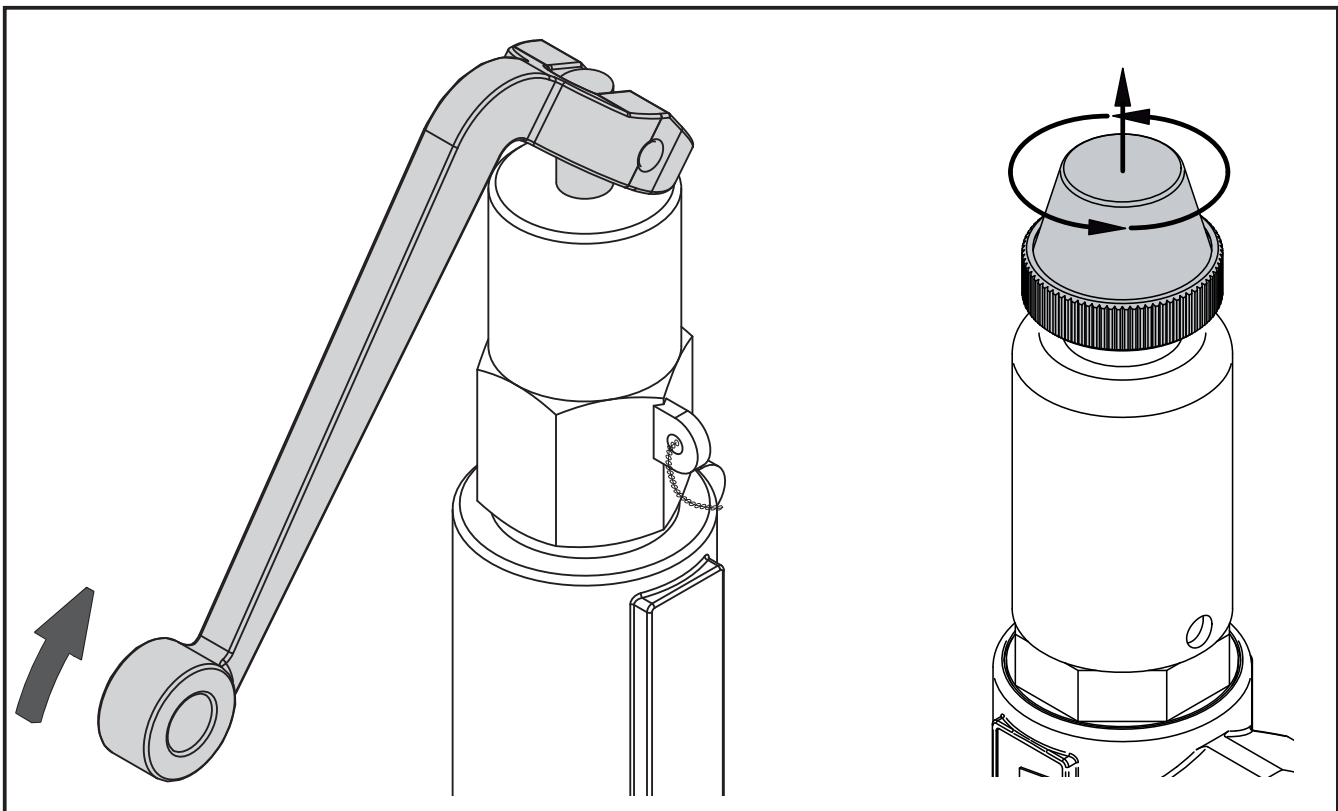





Fig. 4.3 - Safety Valve, Operating of the ventilation

5.5.1 Safety Valve with lifting device

-  A safety valve with a lifting lever will be secured by a binding wire. This locking device of the lifting lever is to be removed only after the installation has been completed.
-  Increase the pressure in the pipes to 85% of the set pressure.
-  Carry out the lifting either by means of a knurled nut above the spring bonnet or by actuating the lifting lever on the upper part of the safety valve.
-  In the event of minor leaks, which may be caused by contamination between the sealing surfaces, the valve can be made to blow off through lifting, for cleaning purposes.

5.5.2 Safety Valve without lifting device



Safety valves without lifting device, like e.g. valves with head "C" (gas tight with cap) should be brought to the release pressure only externally with gas or at a 100% clean device.

5.6 Maintenance

Before you maintain or shut down the safety valve you have to read the



→ **Safety advice**

If you have not read the safety advices until now, read this important advices now and turn back to this point.



Safety valves are designed regarding design and construction in such a way the an optimum of quality is achieved, and that they are easy to service. Therefore a minimum of care and maintenance for the safety valves is required.





The maintenance work, however, is permitted to be carried out only by trained personnel.

5.6.1 Test intervals



In steam generating equipment, testing the ease of movement of safety valves must be carried out at least every 4 weeks in compliance with TRD601.

-  Test intervals for other applications must be determined by the use in compliance with the operating conditions.
-  Tests and examinations are to be executed at least during each internal and external examination of the pertaining pressure device.

5.6.2 Regular releasing of the safety valve



It is recommended to make the safety valve blow off from time to time through lifting, in dependence for the respective system, in order to check the correct operation of the safety valve. The lifting device is not to be operated when in a pressure-free state.



For safety valves with lifting device you have to increase the pressure in the pipes to 85% of the set pressure.



Carry out the lifting either by means of a knurled nut above the spring bonnet or by actuating the lifting lever on the upper part of the safety valve.



Safety valves without lifting device, like e.g. valves with head "C" (gas tight with cap) should be brought to the release pressure only externally with gas or at a 100% clean device.

5.6.3 Leaks



Leaks may be caused in the case of safety valves due to pollution between the valve disc and seat. By operating the lifting device small deposits of pollution can be effectively cleared from the valve disc and seat. (In doing this, a clear stroke of the valve stem must be achieved).



If it fails to remove the pollution by operating the lifting device, it must be assumed that the sealing surfaces are damaged. The damage can be removed by post-processing the sealing surfaces or by changing the seat seal.



Repair work on safety valves is only to be carried out by the manufacturer or by officially approved specialist workshops authorized by the manufacturer.



Leaks may also occur when the operating pressure is too close to the set pressure of the safety valve.

The operating pressure of the device is to be at least 5% lower than the closing pressure of the safety valve.



Qualität von Anfang an.

- (1) **Declaration in conformity**
(2) **as defined by Pressure-Equipment-Directive 97/23/EC**
(3) This declaration apply to the safety valves:

Article	Size	TÜV-Test Certificate	EC-Type Examination Certificate
Safety valve			
NG4011	¼" ... ¾", DN10 ... DN20	TÜV-SV 847	07 202 1111 Z 0178/1/0004 rev. 01
NG4021	¼" ... ¾", DN10 ... DN20	TÜV-SV 847	07 202 1111 Z 0178/1/0004 rev. 01
NG4031	¼" ... ¾", DN10 ... DN20	TÜV-SV 847	07 202 1111 Z 0178/1/0004 rev. 01
NG3011	¼" ... ¾", DN10 ... DN20	TÜV-SV 847	07 202 1111 Z 0178/1/0004 rev. 01
NG3021	¼" ... ¾", DN10 ... DN20	TÜV-SV 847	07 202 1111 Z 0178/1/0004 rev. 01
NG3031	¼" ... ¾", DN10 ... DN20	TÜV-SV 847	07 202 1111 Z 0178/1/0004 rev. 01
NG4011	1" ... 2", DN25 ... DN50	TÜV-SV 878	07 202 1111 Z 0178/1/0005
NG4021	1" ... 2", DN25 ... DN50	TÜV-SV 878	07 202 1111 Z 0178/1/0005
NG4031	1" ... 2", DN25 ... DN50	TÜV-SV 878	07 202 1111 Z 0178/1/0005
NG3011	1" ... 2", DN25 ... DN50	TÜV-SV 878	07 202 1111 Z 0178/1/0005
NG3021	1" ... 2", DN25 ... DN50	TÜV-SV 878	07 202 1111 Z 0178/1/0005
NG3031	1" ... 2", DN25 ... DN50	TÜV-SV 878	07 202 1111 Z 0178/1/0005

and all variations of these articles

- (4) of the company **END-Armaturen GmbH & Co. KG**
D-32547 Bad Oeynhausen
Germany
- (5) Herewith we declare that the above-mentioned safety valves in the conditions of our delivery are in conformity with the regulations of the Pressure Equipment Directive 97/23/EG as well as the national specifications

EN 4126-1
DIN EN 12266
DN EN 12516
AD 2000 Merkblätter A2 and A4
VdTÜVB-Merkblatt Sicherheitsventil 100

- (6) Applied conformity assessment procedure Modul B & D - category IV. There are EC-type examination certificates for the safety valves.
- (7) The monitoring is performed by TÜV CERT-Zertifizierungsstelle der TÜV NORD Gruppe.
Notified body EC-Reg.No. 0045.
- (8) On behalf

Friedhelm König
Technical Manager

 **END-Armaturen GmbH & Co. KG**
Oberbecksener Str. 78
32547 Bad Oeynhausen - Germany
Telefon: +49 (0)5731 - 7900-0
Telefax: +49 (0)5731 - 7900-199
<http://www.end.de> - post@end.de

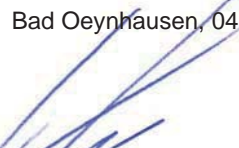
 Bad Oeynhausen, 04. July 2011
Michael End
Quality Manager

Declaration without signature or company stamp shall not be valid. The declaration may be circulated only without alternation.
Extracts or alternations are subject to approval by END-Armaturen GmbH & Co. KG.



Qualität von Anfang an.

- (1) **Declaration in conformity**
(2) **as defined by Pressure-Equipment-Directive 97/23/EC**
(3) This declaration apply to the safety valves:

Article	Size	TÜV-Test Certificate	EC-Type Examination Certificate
Safety valve			
GV	1/2" ... 1 1/2"	TÜV SV 2003	
SV1	1/4" ... 1/2"	TÜV SV 382	01 202 111-B-00026
SV1	3/4" ... 1"	TÜV SV 317	01 202 111-B-00026
SV1	1/4" ... 1"	TÜV SV 2055	01 202 111-B-10-2055
SV2100	1/2" ... 1 1/4"	TÜV SV 318	01 202 111-B-00028
SV2200	1/2" ... 1 1/4"	TÜV SV 268	04 202 1 460 03 00020
SV2410	1/2" ... 1 1/4"	TÜV SV 684	04 202 1 460 03 00020
SV2420	1/2" ... 1 1/4"	TÜV SV 666	01 202 111-B-00029
SV3100	1/2" ... 1 1/4"	TÜV SV 318	01 202 111-B-00028
SV3200	1/2" ... 1 1/4"	TÜV SV 268	04 202 1 460 03 00020
SV3410	1/2" ... 1 1/4"	TÜV SV 684	04 202 1 460 03 00020
SV3420	1/2" ... 1 1/4"	TÜV SV 666	01 202 111-B-00029

and all variations of these articles

- (4) of the company **END-Armaturen GmbH & Co. KG**
D-32547 Bad Oeynhausen
Germany
- (5) Herewith we declare that the above-mentioned safety valves in the conditions of our delivery are in conformity with the regulations of the Pressure Equipment Directive 97/23/EG as well as the national specifications

**AD 2000 Merkblätter A2 and A4
TRD 421 and 721**

- (6) Applied conformity assessment procedure Modul B & D - category IV. There are EC-type examination certificates for the safety valves.
- (7) The monitoring is performed by TÜV-Süddeuschland.
Notified body EC-Reg.No. 0036.

- (8) On behalf



Friedhelm König
Technical Manager

END-Armaturen GmbH & Co. KG
Oberbecksener Str. 78
32547 Bad Oeynhausen - Germany
Telefon: +49 (0)5731 - 7900-0
Telefax: +49 (0)5731 - 7900-199
<http://www.end.de> - post@end.de

Bad Oeynhausen, 04. July 2011

Michael End
Quality Manager

Declaration without signature or company stamp shall not be valid. The declaration may be circulated only without alternation.
Extracts or alternations are subject to approval by END-Armaturen GmbH & Co. KG.

6 Index

B		S	
Blocking devices.....	13	Safety advice.....	8
Blow-off pipe.....	14	- for adjustment / starting.....	9
		- for maintaining / repairing.....	9
		- for mounting.....	8
C		Safety Valve with lifting device.....	17
Code letters.....	11	Safety Valve without lifting device.....	17
Commissioning.....	16	Set pressure.....	11, 13, 14, 17, 18
Complaints.....	6	Sticky effect.....	16
Condensate diversion.....	15	Storage.....	12
Corresponding use.....	12	Symbols and their signification.....	7
D			
Device safety.....	10	T	
Directive 97/23/EC.....	12	Test intervals.....	17
Disassembly.....	13, 16	TRD601.....	17
F			
Foreword.....	5	V	
G		Validity.....	6
Gas tight.....	17	Ventilation.....	12
I			
Identification.....	11	W	
Inlet pipe.....	13	Warranty.....	6
Inward monitoring.....	6		
L			
Leaks.....	18		
M			
Maintenance.....	17		
Mounting.....	13		
N			
Non-flamable media.....	15		
Non-toxic media.....	15		
O			
Open discharge Safety Valves.....	15		
Operation.....	12		
P			
Personal advice.....	8		
Prolonged storage.....	16		
R			
Regular releasing.....	18		



Qualität von Anfang an.

Qualität von Anfang an.

END-Armaturen GmbH & Co. KG
 Oberbecksener Str.78
 D-32547 Bad Oeynhausen
 Postfach (PLZ 32503) 100 341
 Telefon +49 (0) 5731 / 7900-0
 Telefax +49 (0) 5731 / 7900-199
 Internet <http://www.end.de>
 E-Mail post@end.de

END-Automation GmbH & Co. KG
 Oberbecksener Str.78
 D-32547 Bad Oeynhausen
 Postfach (PLZ 32503) 100 342
 Telefon +49 (0) 5731 / 7901-0
 Telefax +49 (0) 5731 / 7901-999
 Internet <http://www.end.de>
 E-Mail post@end.de

Watergates GmbH & Co. KG
 Oberbecksener Str.70
 D-32547 Bad Oeynhausen
 Postfach (PLZ 32503) 100 321
 Telefon +49 (0) 5731 / 7900-0
 Telefax +49 (0) 5731 / 7900-199
 Internet <http://www.watergates.de>
 E-Mail post@watergates.de



N° INT80209DE