

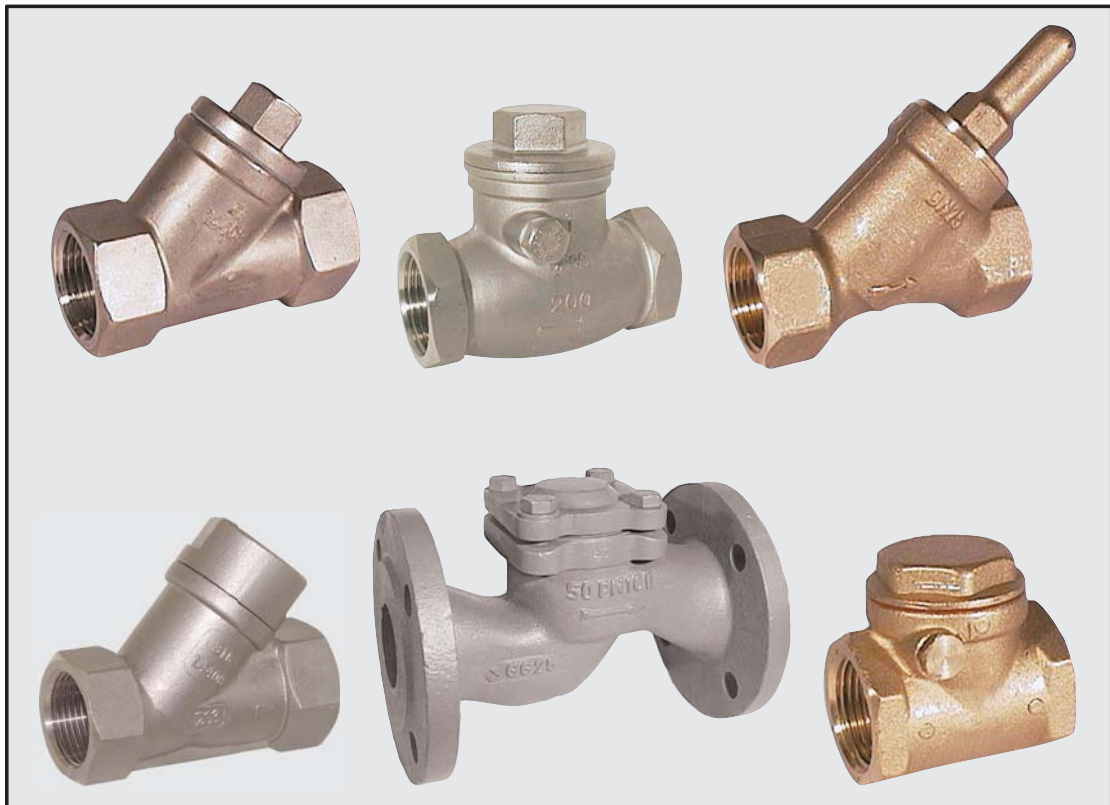

Qualität von Anfang an.

Mounting and Operating Manual Non-Return valves Swing-Check valves



© by **END-Armaturen GmbH & Co. KG**

All rights reserved. **END-Armaturen GmbH & Co. KG** claims copyright over this documentation. This documentation may neither be altered, expanded, reproduced nor passed to third parties without the written agreement of **END-Armaturen GmbH & Co. KG**. This restriction also applies to the corresponding drawings.

END-Armaturen GmbH & Co. KG has the right to change parts of the non-return valves / swing check valves at any time without prior or direct notice to the client. The contents of this publication are subject to change without notice.

This publication has been written with great care. However, **END-Armaturen GmbH & Co. KG** cannot be held responsible, either for any errors occurring in this publication or for their consequences.

The products are specified by the statements in this documentation; no assurance of the properties is given.

END-Armaturen GmbH & Co. KG

Oberbecksener Straße 78
D-32547 Bad Oeynhausen
Telefon: 05731 / 7900 - 0
Telefax: 05731 / 7900 - 80
Internet: <http://www.end.de>
E-Mail: post@end.de

Edition: 11/02

Contents

1	Foreword	4
2	General Advice	5
2.1	Validity	5
2.2	Inward monitoring	5
2.3	Complaints	5
2.4	Guarantee	5
2.5	Symbols and their signification	6
3	Safety Advice	7
3.1	Personal advice	7
3.1.1	Safety advices for mounting	7
3.1.3	Safety advice for maintaining / repairing	8
3.2	Device safety	9
4	Name-plate	10
5	Non-Return valves, Swing-Check valves	11
5.1	General	11
5.2	Corresponding use	11
5.3	Operation	11
5.4	Mounting / Disassemble	11
5.4.1	Mounting with threaded connection	12
5.4.2	Mounting with welded connection	12
5.4.2.1	Disassemble of the bonnet and the inner parts	13
5.4.2.2	Welding the body between pipes	13
5.4.2.3	Mounting of the bonnet and the inner parts	14
5.4.3	Mounting of the valve with flanged connection	15
5.5	Maintenance	15
6	Declaration in conformity as defined by Pressure-Equipment-Directive 97/23/EC	18

Foreword

1 Foreword

Dear customer,
Dear assembler / user,

these operation and installation manuals are intended to give you the knowledge, which is necessary for you to be able to carry out the mounting and adjustment of the non-return valves / swing-check valves rapidly and correctly.



Please read these instructions carefully and pay particular attention to the advice and warning notes.

Only instructed and qualified mechanician should mount, adjust or maintain the non-return valves / swing-check valves.

If you have any questions in relation to the non-return valves / swing-check valves we shall be pleased to answer them.

The telephone number will be found on the inside cover of these operation and installation manual.

Yours

END-Armaturen GmbH & Co. KG

2 General Advice

2.1 Validity

This mounting and installation manual is valid for the standard versions of the non-return valves / swing-check valves and their variants.

2.2 Inward monitoring

Please check directly after delivery the non-return valves /swing-check valves for any transport damages and deficiencies and with reference to the accompanying delivery note the number of parts.

Do not leave any parts in the package.

2.3 Complaints

Claims for replacement or goods which relate to transport damage can only be considered valid if the delivery company is notified without delay.

In case of returns (because of transport damage / repairs), please make a damage protocol and send the parts back to the manufacturer, if possible in the original packaging.

In case of a return, please mention the following:

- Name and address of the consignee
- Stock-/ ordering-/ article-number
- Description of the defect

2.4 Warranty

For our non-return valves / swing-check valves we give a guarantee period in accordance with the sales contract.

The end of the normal duration of life of the wearing parts represents no defect.

The warranty and guarantee rules of **END-Armaturen GmbH & Co. KG** are applicable.

Symbols and their signification

2.5 Symbols and their signification



Paragraphs which are identified with this symbol contain very important advices; this also includes advices for averting health risks. Observe these paragraphs without fail!



Paragraphs which are identified with this symbol contain very important advices, this also includes how to avoid damage to property. Observe these paragraphs without fail!



This symbol indicates paragraphs which contain comments / advices or tips.



This spanner identifies the description of actions which you should carry out.

3 Safety Advice

Depending on the technical circumstances and the time under and at which the non-return valves / swing-check valves are mounted, adjusted and commissioned, you must take into account particular safety aspects in each case!

If, for example, a non-return valve / swing-check valve works a slide in an operational chemical plant, the potential hazards of commissioning have another dimension from that when this is only being carried out for test purposes on a „dry“ part of the plant in the assembly room!

Since we do not know the circumstances at the time of the mounting/adjustment/commissioning, you may find advices on hazards in the following descriptions which are not relevant to you.

Please observe (only) the advices which applies to your situation!

3.1 Personal advice

3.1.1 Safety advices for mounting



We wish to point out expressly that the mounting, adjusting and at accessories the pneumatical and electrical installation of the butterfly valves must be carried out by trained specialist personnel having mechanical, pneumatical and electrical knowledge!



Secure that the machine / plant come up to the Machinery Directive after the mounting and installing of the ball valves.



Switch off all the devices / machines / plant affected by mounting or repair. If appropriate, isolate the devices / machines / plant from the mains.



Check (for example in chemical plants) whether the switching off of devices / machines / plant will cause potential danger.



If appropriate, in the event of a fault in the butterfly valve (in a plant which is in operation) inform the shift foreman / safety engineer or the works manager without delay about the fault, in order, for example, to avoid an outflow / overflow of chemicals or the discharge of gases in good time by means of suitable measures!



Before mounting or repairing, remove the pressure from pneumatic / hydraulic devices / machines / plant.



If necessary, set up warning signs in order to prevent the inadvertent starting up of the devices / machines / plant.



Observe the respective relevant professional safety and accident prevention regulations when carrying out the mounting / repair work.



Check the correct functioning of the safety equipment (for example the emergency push off buttons/ safety valves, etc)!

3.1.2 Safety advice for adjustment / starting



As a result of the starting of the non-return valves / swing-check valves the flow of gases, steam, liquids, etc. may be enabled or interrupted! Satisfy yourself that, as a result of the starting or the test adjustment no potential hazards will be produced for the personnel or the environment!

Safety Advice



If necessary, set up warning signs in order to prevent the inadvertent starting up or shutting down of the device / machine / plant.!



By ending the adjustment check the correct function and should the occasion arise the position of the non-return valve / swing-check valve.



Check the function of the limit switches (option)!



Check, whether the armature will be closed totally, if the control signals the appropriate limit stop!



Through suitable measures, prevent links being trapped by moving actuating elements!



Check the right function of all safety devices (for example emergency push off buttons / safety valves)!



Carry out the starting and the adjustments only in accordance with the instructions discribed in this documentation!



Adjusting switches on ball valves with options (e.g. actuators, solenoid valves, limit switches) there is the risk that live parts (230 V AC~) can be touched!
Therefore the adjustments must be carried out only by the electrician or a person having adequate training, who is aware of the potential hazard!

3.1.3 Safety advice for maintaining / repairing



Do not carry out any maintenances / repairs if the non-return vales / swing check valves will be under pressure.

Before disassembling the armature some essential points should be clarified!

- Will the non-return valves / swing-check valves to be disassembled be replaced by another immediately?
- If appropriate, does the production process of the plant needed to be stopped?
- Is it necessary to inform specific personnel about the disassembly?



If necessary, inform the shift foreman/ safety engineer or the manager about the maintenance or repair without delay in order, for example, to avoid an outflow/ overflow of chemicals or a discharge of gases in good time by means of suitable measures!



You have to relieve the pressure in the pipes in which the butterfly valve is mounted.



Switch off pilot pressure and the power supply and relieve the pressure in the pipes.



If necessary set up warning signs in order to prevent

- the inadvertent starting up of the devices/machines/plants in which the armature is mounted
- the switching on of pilot medium supply, pilot power supply and/or the power supply of actuators and accessories.



In case of defect in the non-return vales / swing check valves make contact to the supplier. The telephone number will be found on the back cover of these mounting and installation manual.



If you ascertain a damage of the non-return valves / swing check valves, isolate the device from the mains. Please observe the safety advices.



Do not mount, start or adjust the non-return valves / swing check valves if itself, the pipes or a mounted actuator will be damaged.



After the maintenance or repair check the right function of the non-return valves / swing check valves and the tightness of the pipe connections.



Also check the function of the accessories e.g. actuators, limit switches, etc.

3.2 Device safety

The non-return valves / swing-check valves

- are quality products which are produced in accordance to the recognized industrial regulations.
- left the manufacturer`s work in a perfect safety condition.



In order to maintain this condition, as installer / user you must carry out your task in accordance with the description in these instructions, technically correctly and with the greatest possible precision .

We assume, as a trained specialist you are having mechanical and electrical knowledge!



Satisfy yourself that the non-return valves /swing check valves will only be used within their admissible limiting value (see the technical data) .



The non-return valves / swing check valves must be used only for a purpose corresponding to their construction!



The non-return valves / swing check valves must be used within the values specified in the technical data!



The operating of the non-return valves / swing check valves outside the nominal temperature range could destroy the seals and the bearings.

The operating of the non-return valves / swing check valves outside the nominal pressure range could destroy the inner parts and the body.



Do not mount, start or adjust the non-return valves / swing check valves if itself, the pipes or a mounted actuator will be damaged.



After the maintenance or repair check the right function of the non-return valves / swing check valves and the tightness of the pipe connections.



Also check the function of the accessories e.g. actuators, limit switches, etc.

Name-plate

4 Name-plate

In some cases the armatures/valves will be provided with a name-plate, which permits a definite identification of the armatures/valves and shows the most important technical data to you. The name-plate should not be displaced or changed.

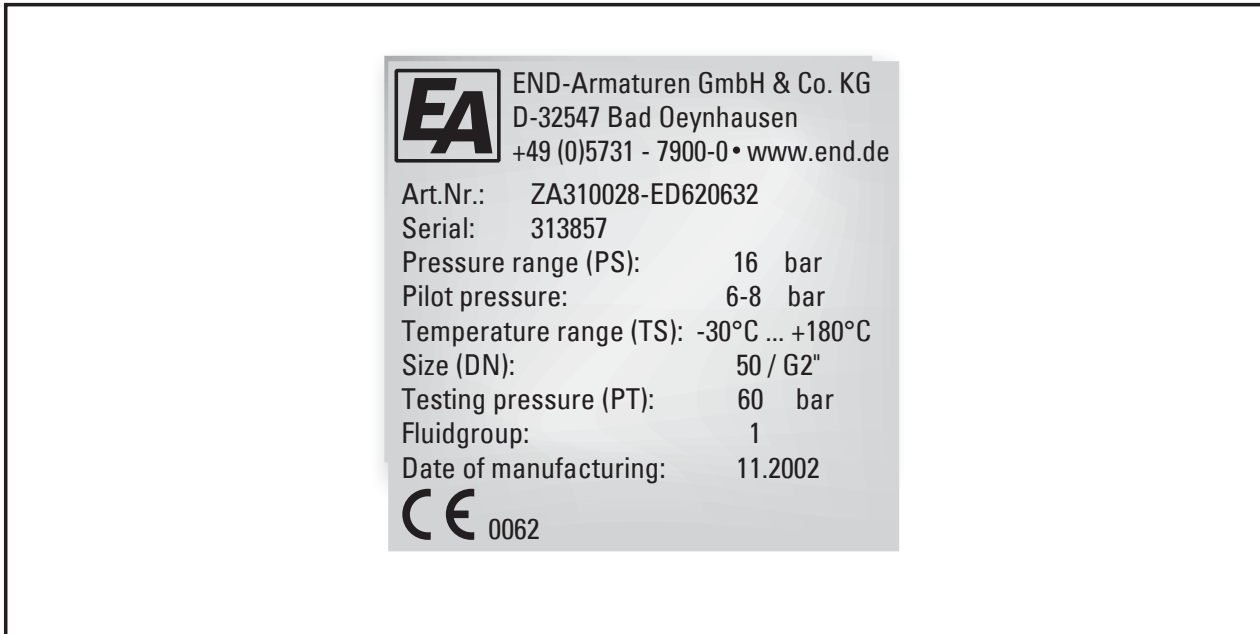

Fig. 4.1 - name-plate

Art.No.	article number of the valve / armature
Serial	order- or production- number
Pressure range (PS)	max. admissible working pressure of the valve / armature [bar]
Pilot pressure	recommend pilot pressure for correct function of the valve / armature [bar] (only at pneumatic actuated valves / armatures)
Size (DN)	connecting size of the valve / armature
Testing pressure (PT)	testing pressure of the body of the valve / armature
Fluidgroup	allowed fluidgroup of the valve / armature
Date of manufacturing	month and year of manufacturing of the valve / armature

5 Non-Return valves, Swing-Check valves

5.1 General

Before you mount /disassemble, adjust or commission a non-return valve or a swing-check valve you must have read the



→ Safety advice

If you have not read the safety advices until now please read these important advices now and turn back to this point.

5.2 Corresponding use

Non-return valves and swing-check valves are used to prevent the back-flow of media. It should only be used clean liquids and gases, on which the material of the valves and the material of the sealings will be resistant. Pollution or using outside the nominal pressure range and/or the nominal temperature range should causes damages on the valves especially on the seals.

5.3 Operation

Non-return valves and swing-check vales need no special operation .

5.4 Mounting / Disassemble

The mechanical mounting is identical in all variants. It differs only by the type of connection.



Observe the flow direction which is specified on the valve body. The installation of a swing-check valves will have take place that the flap of the swing-check valve will close by the force of gravity automatically.



Please observe that that the installation of the swing-check valve / non-return valve will have influence on the opening pressure.



Remove all transport safety devices (e.g. plugs or caps). Observe that there won't be any parts of the package or other pollution in the armature.



Before mounting swing-check valve / non-return valve clean up the pipes. Pollution will reduce the safety and the duration of life of the armature.

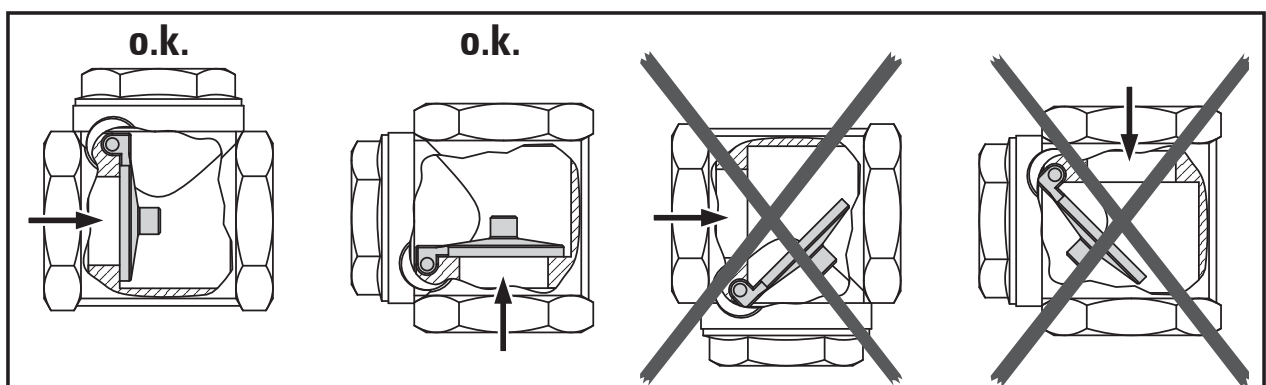



Fig. 5.1 - non-return valve, swing-check valve, installation (Fig.: Art. TR100025).

Non-Return valves, Swing-Check valves

 Avoid stress in case of non align pipes.

5.4.1 Mounting with threaded connection

 Before lay on sealing compounds, check the hardly screwing by the pipes into the valve body.

 Lay on the correct sealing compounds on the pipes end. By using PTFE-ribbon or hemp seals observe the screw direction. Don't use sealing compounds which are not prescribed for your employment.

 Screw the pipes into the connection ends of the valve.

 Strike up the pipes with pressure after that time the manufacturer of the sealing compounds pre-tends to harden it.

 Check the tightness of all connections.

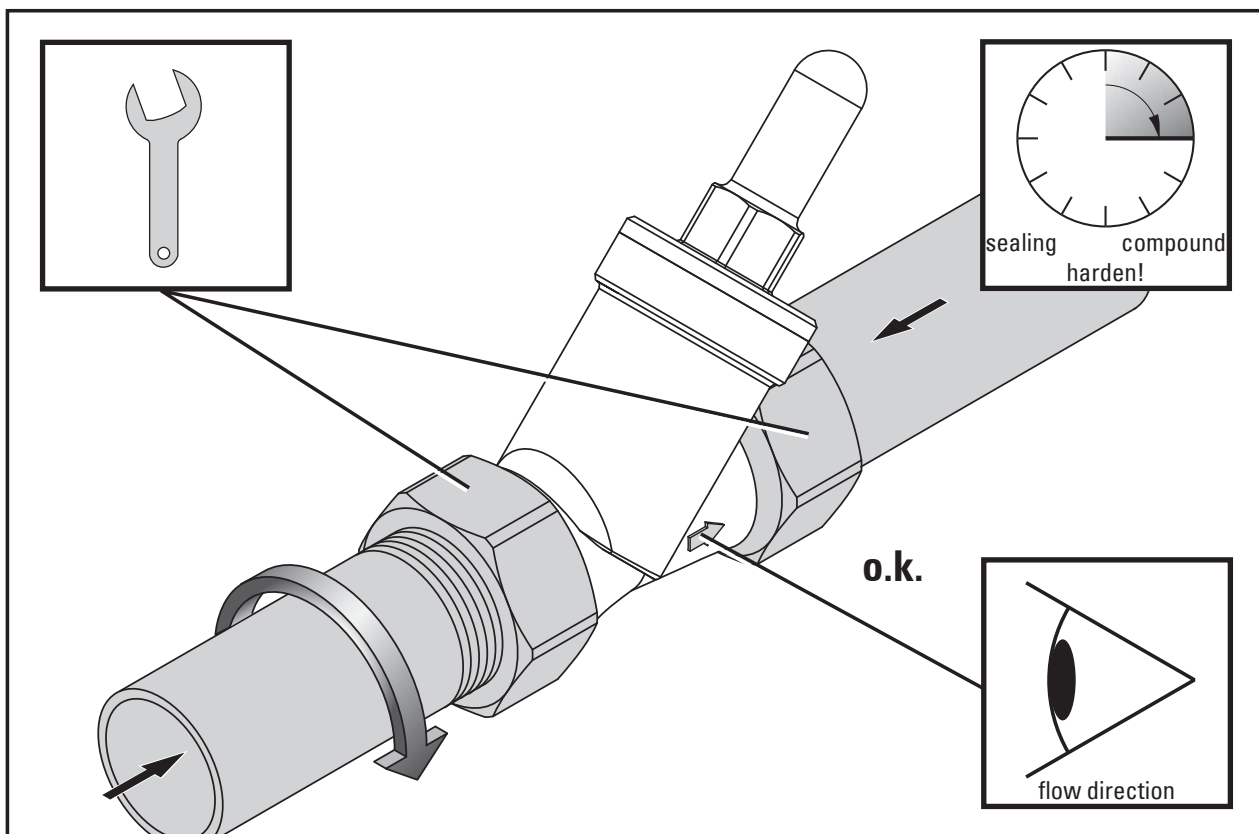





Fig. 5.2 - non-return valves, swing-check valves, mounting with threaded connection (Fig.: Art. BH120025)

5.4.2 Mounting with welded connection



Before welding the valve between the pipes you have to disassemble the bonnet of the non-return valve first, to prevent the damage of the seals.

5.4.2.1 Disassemble of the bonnet and the inner parts

-  Clamp the valve between a vice carefully. By using guard plates you can prevent the damage of the ends of the valve body.
-  Loosen the bonnet with a fit spanner.
-  Screw the bonnet out of the body. By doing this be very careful, because there will be a resilience on the bonnet. Take the spring and the inner part out of the bonnet and put the parts aside.

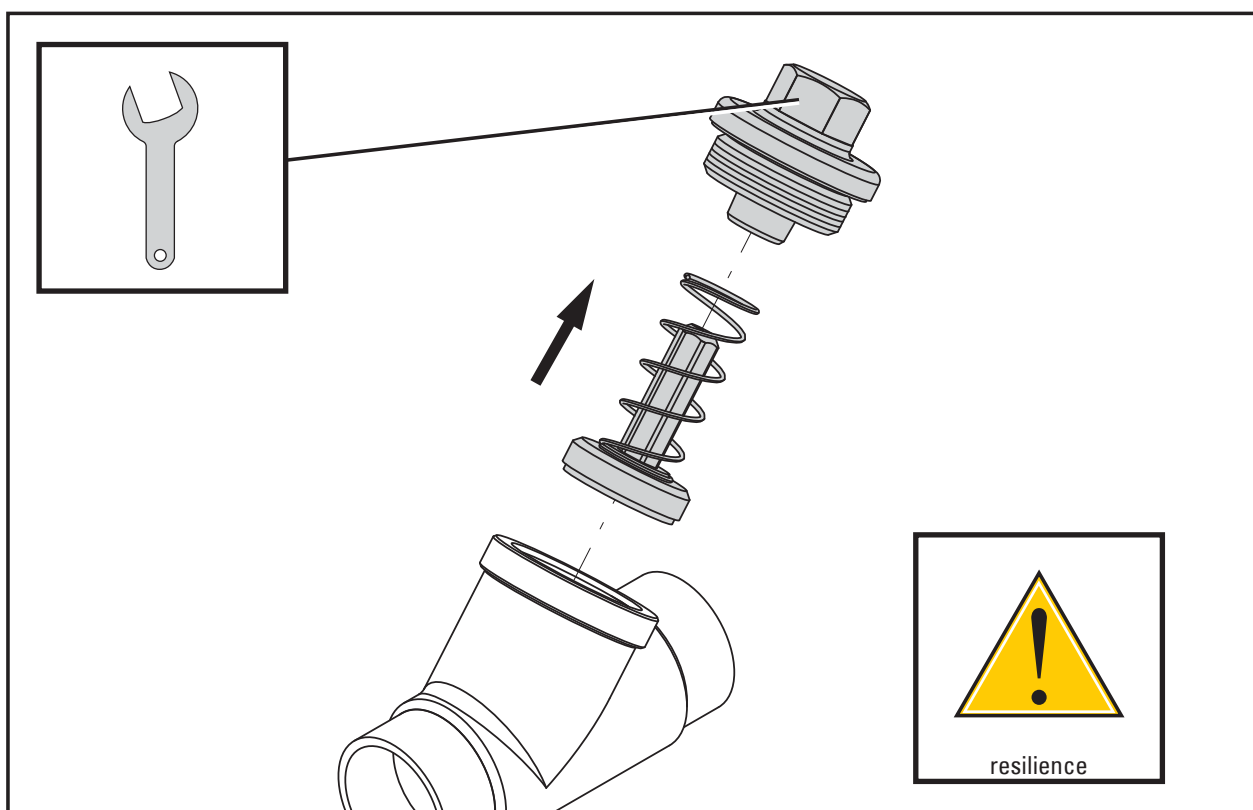





Fig. 5.3 - non-return valves, swing check valve, disassembly of the bonnet and the inner parts (Fig.: Art. EB310064)

5.4.2.2 Welding the body between pipes

-  By welding the valve body with the pipes observe appropriate demands and guide lines.
-  The safety demands be welding are depending on the place and the position of the point of weld. Welding the parts in a serviceable device/machine/plant the potential of danger is as higher as welding the parts in a welding room.
-  If appropriate inform the shift foreman / safety engineer or the works manager and the fire brigade of your factory.
- By welding observe your own national guide lines about safety and the prevention of accidents.

Non-Return valves, Swing-Check valves

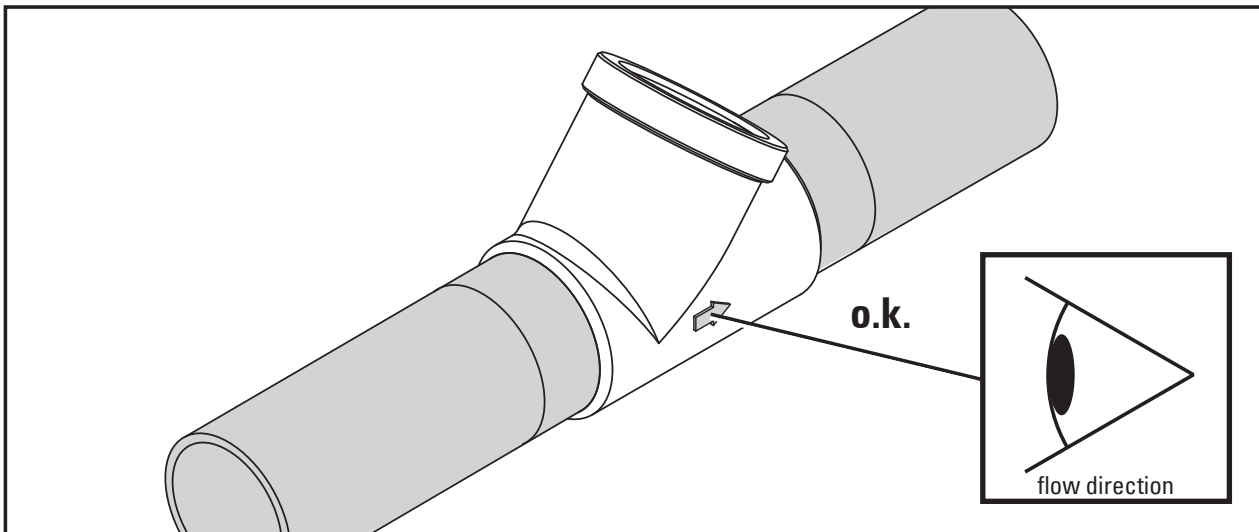

Fig. 5.4 - non-return valves, swing-check valves, welding of the body (Fig.: body of Art. EB310064)

5.4.2.3 Mounting of the bonnet and the inner parts



Before mounting the bonnet and the inner parts let the body cool down.



Insert the inner parts and the spring into the body. Take care about the correct placement of the inner parts and the spring.



Screw the bonnet into the body. Check the correct position of the sealing at the bonnet and take care that there will be no pollution on the sealing or on the seat.



Tighten the bonnet with a fit spanner.



Check the tightness of all connections.

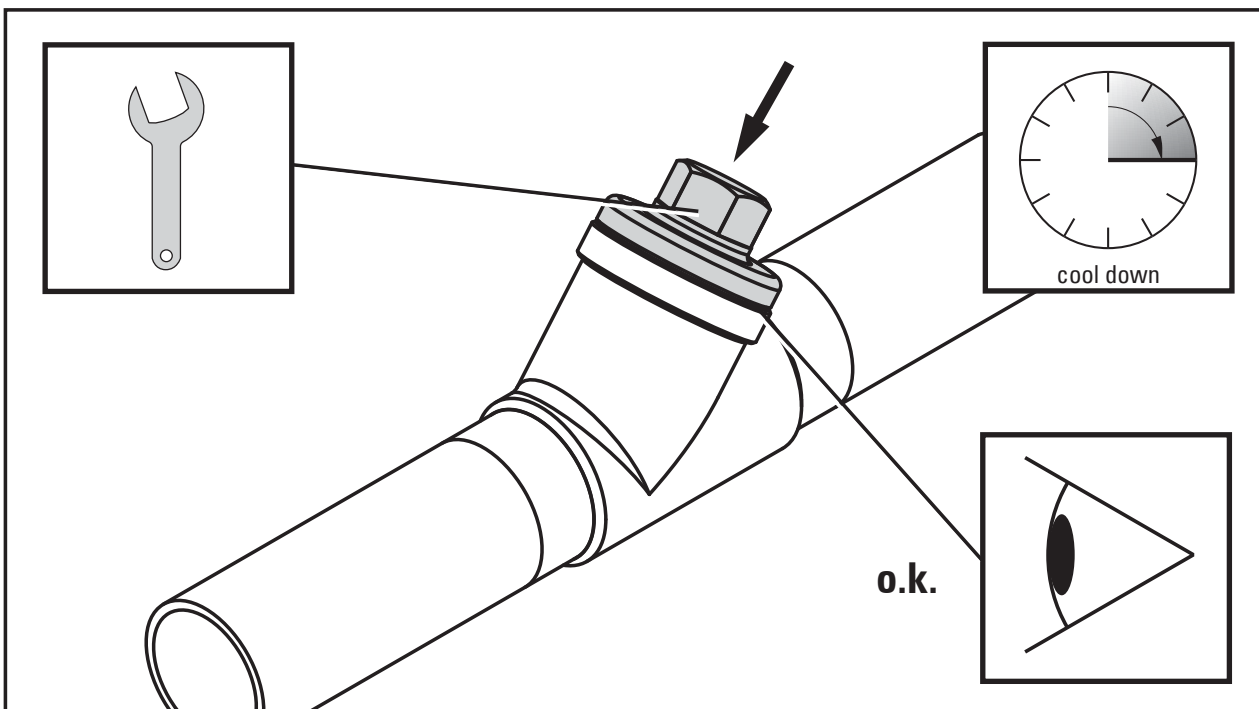

Fig. 5.5 - non-return valve, swing-check valve, mounting of the bonnet and the inner parts (Fig.: Art. EB310064)

5.4.3 Mounting of the valve with flanged connection



In the following description we assume that you have mounted the flanges at the end of the pipes and the valve (welded flanges) and they are cooled down..



Push the valve between the flanges by using the appropriate seals. This process must happen easily to avoid the damage of the seals.



Align the borings of the flanges and put some fit screws through the holes. Screw the fit nuts onto the screws and tighten them up crosswise.



Fasten all screws crosswise and check the function of the valve. Observe the maximum torque of the screws.



Check the tightness of all connections.

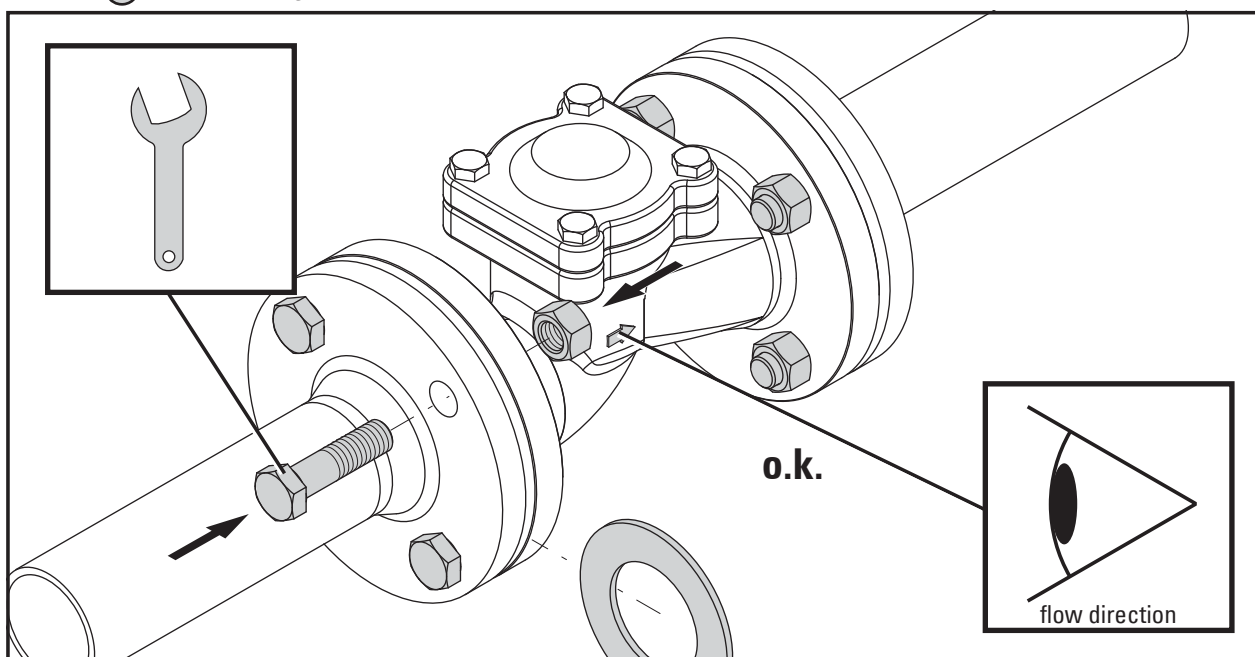

Fig. 5.6 - non-return valves, swing-check valve, mounting with flanged connection (Fig.: Art. KU3000xx)

5.5 Maintenance



Before you maintain or shut down a non-return valve / swing-check valve you have to read the

→ **Safety advice**

If you have not read the safety advices until now, read this important advices now and turn back to this page.

Non-return valves need on maintenance



In case of a defect of the valve make a contact to the supplier. The telephone number will be found on the back of these operation and installation manual.

If you determinate that there is a damage to the valve switch off the device/ machine/ plant! However before doing this, it is essential to refer to the

→ **Safety advice.**



Qualität von Anfang an.

(1) **Declaration in conformity**
(2) **as defined by Pressure-Equipment-Directive 97/23/EC**

(3) This declaration apply to the article groups with the nominal sizes:

Articles	Nominal size	Articles	Nominal size	Articles	Nominal size	Articles	Nominal size
Butterfly valves		NG	DN32 ... DN100	VO	DN32 ... DN200	Non-return valves	
HA	DN50 ... DN300	Ball valves		VS	DN32 ... DN200	AR	1 1/4" ... 2"
TA	DN40 ... DN300	AG	1 1/4" ... 2"	VT	DN32 ... DN100	CK3003	DN65 ... DN200
WA	DN50 ... DN300	BK	DN32 ... DN100	VU	4"	CK5003	DN32 ... DN200
WM	DN50 ... DN300	IK	1 1/4" ... 2"	ZA	1 1/4" ... 4"	CK5100	DN65 ... DN250
Gate valves		IL	1 1/4" ... 4"	ZA	DN32 ... DN100	CK5200	DN65 ... DN250
AB	1 1/4" ... 2"	IW	1 1/4" ... 2"	ZB	1 1/4" ... 2"	CW5400	DN65 ... DN250
AE	1 1/4" ... 3"	KA	1 1/4" ... 3"	ZB	DN32 ... DN50	EB	1 1/4" ... 3"
AE	DN32 ... DN80	PD	1 1/4" ... 2"	ZD	1 1/4" ... 4"	EB	DN32 ... DN80
CA5014	DN100 ... DN300	TB	1 1/4" ... 4"	ZD	DN32 ... DN100	RG1300	DN32 ... DN100
CA5015	DN65 ... DN300	TF	DN32 ... DN200	ZE	1 1/4" ... 4"	RG33xx	DN32 ... DN200
CA5214	DN40 ... DN200	TH	1 1/4"	ZE	DN32 ... DN100	RK	DN32 ... DN400
CD5010	DN32 ... DN200	VD	1 1/4" ... 4"	ZF	1 1/4" ... 4"	TD	4"
CV3010	DN32 ... DN150	VD	DN32 ... DN100	ZG	1 1/4" ... 2"	Strainer	
CV5010	DN32 ... DN200	VH	1 1/4" ... 2"	ZH	1 1/4" ... 2"	AS	1 1/4" ... 3"
CV5020	DN32 ... DN200	VH3100	1 1/4" ... 2"	ZK	DN32 ... DN100	AS	DN32 ... DN200
Pressure reducer		VK	DN32 ... DN200	ZL	1 1/4" ... 3"	EA	1 1/4" ... 3"
SD	3/4" ... 2"	VK/PN40	DN32 ... DN200	ZM	1 1/4" ... 2"	EA	DN32 ... DN80
Pressure relief valves		VL	1 1/4" ... 2", 3"	ZP	DN32 ... DN200		
NG	1 1/4" ... 1 1/2"	VN	1 1/4" ... 2"	ZU	1 1/4" ... 3"		

and all variations of these articles

(4) of the company **END-Armaturen GmbH & Co. KG**
D-32547 Bad Oeynhausen
Germany

(5) Herewith we declare that the above-mentioned articles in the conditions of our delivery are in conformity with the regulations of the Pressure Equipment Directive 97/23/EG.

(6) Applied conformity assessment procedure: Modul H.

(7) Notified body for conformity assessment PED an Quality-Management-System:



Bureau Veritas S.A.
Paris / Frankreich
Kennzeichen 0062

(8) Certificate numbers: Quality Management System: INT110198DE
Certificate of System approval PED: 2011/70.10.1777/P

(9) Applied harmonized standards, in particular:

DIN EN 12516:2005 **Industriearmaturen - Gehäusefestigkeit**

(10) On behalf  Bad Oeynhausen, 07. July 2011

Friedhelm König
Technical Manager

END-Armaturen GmbH & Co. KG
Oberbecksener Str. 78
32547 Bad Oeynhausen · Germany
Telefon: +49 (0)5731 - 7900-0
Telefax: +49 (0)5731 - 7900-199
<http://www.end.de> · post@end.de

Michael End
Quality Manager

Declaration without signature or company stamp shall not be valid. The declaration may be circulated only without alteration. Extracts or alternations are subject to approval by END-Armaturen GmbH & Co. KG.





Qualität von Anfang an.

(1) **Declaration in conformity**
(2) **as defined by Pressure-Equipment-Directive 97/23/EC**

(3) This declaration apply to the article groups with the nominal sizes:

Articles	Nominal size	Articles	Nominal size	Articles	Nominal size	Articles	Nominal size
Gate valves		BT	1/2" ... 1"	VN	1/4" ... 1"	CK3003	DN15 ... DN50
AA	1/2" ... 2"	BV	1/4" ... 3/4"	VO	DN25	CK5000	DN40 ... DN250
AB	1/4" ... 1"	CB	1/4" ... 2 1/2"	VS	DN15 ... DN25	CK5003	DN40 ... DN25
AC	1/6" ... 2"	CO-CO	1/2" ... 2"	VT	DN15 ... DN25	CK5100	DN40 ... DN50
AD	1/2" ... 2"	HF	1/4" ... 1"	ZA	1/4" ... 1", DN10 ... DN25	CK5200	DN40 ... DN50
AE	1/2" ... 1", DN15 ... DN25	HO	DN10 ... DN15	ZB	1/4" ... 1", DN15 ... DN25	CW5400	DN40 ... DN50
AV	1/4" ... 1"	IB	1/4" ... 2"	ZD	1/2" ... 1", DN15 ... DN25	DR	DN50 ... DN300
BE	3/8" ... 3"	IK	1/4" ... 1"	ZE	1/4" ... 1", DN10 ... DN25	EB	1/2" ... 1", DN15 ... DN25
BF	1/4" ... 3"	IL	1/4" ... 1"	ZF	1/4" ... 1"	MR	1/4" ... 3"
BS	1/2" ... 1 1/4"	IW	1/4" ... 1"	ZG	1/4" ... 1"	RG	DN15 ... DN25
CA5014	DN40 ... DN80	KA	1/2" ... 1"	ZH	1/2" ... 1"	TD	3/8" ... 3"
CA5015	DN40 ... DN50	KFE	3/8" ... 3/4"	ZK	DN15 ... DN25	TG	1/2" ... 2"
CA5214	DN40 ... DN32	NK	3/8" ... 4", DN10 ... DN100	ZL	1/4" ... 1"	TR	3/8" ... 4"
CD5010	DN15 ... DN25	PB	1/4" ... 2"	ZM	1/4" ... 1"	VB	1/4" ... 2"
CV3010	DN15 ... DN25	PD	1/2" ... 1"	ZP	DN15 ... DN25	ZR	DN15 ... DN200
CV5010	DN15 ... DN25	SK	1/2" ... 3", DN10 ... DN80	ZU	1/4" ... 1"	Sight glasses	
CV5020	DN15 ... DN25	TB	1/4" ... 1"	Pipe fittings		SG	1/4" ... 2", DN15 ... DN150
IC	1/4" ... 4"	TE	1/2" ... 2"	FG	1/8" ... 4"	Strainer	
MV	1/2"	TF	DN20 ... DN25	FS	DN15 ... DN150	AS	1/4" ... 1"
TC	1/4" ... 4"	TH	1/2" ... 1"	GE	Ø6 ... Ø20	AS	DN15 ... DN25
Pressure reducer		TT	3/8" ... 1"	GR	Ø8 ... Ø28	BG	3/8" ... 2"
ID	3/8" ... 3/4"	TV	3/8" ... 1"	GV	Ø6 ... Ø20	CU	DN15 ... DN250
MB	1/2" ... 2"	VD	1/4" ... 1"	TE	Ø6 ... Ø25	EA	1/2" ... 1", DN15 ... DN25
MC	1/2" ... 2"	VD	DN10 ... DN25	TV	Ø6 ... Ø20	IG	1/4" ... 4"
Pressure relief valves		VE	1/4" ... 1"	WE	Ø6 ... Ø38	KU	DN15 ... DN100
NG	3/8" ... 1", DN15 ... DN25	VF	1/4" ... 1/2"	WV	Ø6 ... Ø20	Water-shock damper	
Ball valves		VH	1/4" ... 1"	Non-return valves		TS	1/2"
AG	1/4" ... 1"	VH3100	1/2" ... 1"	AH	1/4" ... 1 1/2"		
BC	1/8" ... 3/4"	VK	DN15 ... DN25	AR	1/2" ... 1"		
BK	DN15 ... DN25	VL	1/4" ... 1"	BH	3/8" ... 3"		

and all variations of these articles

(4) of the company **END-Armaturen GmbH & Co. KG**
D-32547 Bad Oeynhausen
Germany

(5) Herewith we declare that the above-mentioned articles in the conditions of our delivery are in conformity with the regulations of Article 3 Part 3 of the directive 97/23/EG. These products bear no CE mark, but are in line to the good engineering practice designed and manufactured.

(6) Applied harmonized standards, in particular:

DIN EN 12516:2005 Industriearmaturen - Gehäusefestigkeit

(7) On behalf

F. König



END-Armaturen GmbH & Co. KG
Oberbeckener Str. 78
32547 Bad Oeynhausen · Germany
Telefon: +49 (0)5731 - 7900-0
Telefax: +49 (0)5731 - 7900-199
http://www.end.de · post@end.de

Bad Oeynhausen, 04. July 2011

Friedhelm König
Technical Manager

Michael End
Michael End
Quality Manager

Declaration without signature or company stamp shall not be valid. The declaration may be circulated only without alternation. Extracts or alternations are subject to approval by END-Armaturen GmbH & Co. KG.





Qualität von Anfang an.

Qualität von Anfang an.

END-Armaturen GmbH & Co. KG
 Oberbecksener Str.78
 D-32547 Bad Oeynhausen
 Postfach (PLZ 32503) 100 341
 Telefon +49 (0) 5731 / 7900-0
 Telefax +49 (0) 5731 / 7900-199
 Internet <http://www.end.de>
 E-Mail post@end.de

END-Automation GmbH & Co. KG
 Oberbecksener Str.78
 D-32547 Bad Oeynhausen
 Postfach (PLZ 32503) 100 342
 Telefon +49 (0) 5731 / 7901-0
 Telefax +49 (0) 5731 / 7901-999
 Internet <http://www.end.de>
 E-Mail post@end.de

Watergates GmbH & Co. KG
 Oberbecksener Str.70
 D-32547 Bad Oeynhausen
 Postfach (PLZ 32503) 100 321
 Telefon +49 (0) 5731 / 7900-0
 Telefax +49 (0) 5731 / 7900-199
 Internet <http://www.watergates.de>
 E-Mail post@watergates.de