



Qualität von Anfang an.

Original Operating Manual Electric Actuator RT



acc. to annex VI of the Directive 2006/42/EC



© by **END-Armaturen GmbH & Co. KG**

All rights reserved. **END-Armaturen GmbH & Co. KG** claims copyright over this documentation.

This documentation may neither be altered, expended, reproduced nor passed to third parties without the written agreement of the **END-Armaturen GmbH & Co. KG**. This restriction also applies to the corresponding drawings.

END-Armaturen GmbH & Co. KG has the right to change parts of the actuator at any time without prior or direct notice to the client. The contents of this publication are subject to change without notice.

This publication has been written with great care. However **END-Armaturen GmbH & Co. KG** cannot be held responsible, either for any errors occurring in this publication or for there consequences.

The products are specified by the statements in this documentation; no assurance of the properties is given.

END-Armaturen GmbH & Co. KG

Oberbecksener Straße 78

D-32547 Bad Oeynhausen

Telefon: 05731 / 7900 - 0

Telefax: 05731 / 7900 - 199

Internet: <http://www.end.de>

E-Mail: post@end.de

Edition: 19.01.2011

The right is reserved to change designs and devices.

Content

1	Foreword	5
2	General advice	6
2.1	Validity	6
2.2	Inward monitoring	6
2.3	Complains	6
2.4	Guarantee	6
2.5	Symbols and their signification	7
3	Safety advice	8
3.1	Personal protection	8
3.1.1	Safety advice for mounting	8
3.1.2	Safety advice for adjustment and starting	9
3.2	Device safety	10
4	Device description	11
4.1	Device description RT	11
4.2	Device variants	12
4.3	Name-plate	12
5	Ambient conditions	13
6	Assembly instructions	13
6.1	Mechanical mounting	14
6.1.1	Mounting of the removable plate (only RT20xx)	14
6.1.2	Mounting of the actuator / actuating element	15
6.2	Electrical installation	16
6.2.1	Dismounting of the actuator cover	16
6.2.2	Connecting of the power supply and the limit switches	16
6.3	Disassembly	18
6.3.1	Electrical disassembly	18
6.3.2	Mechanical disassembly	18
7	Adjustment / Starting	19
7.1	Adjustments	19
7.1.1	Adjustment of the limit switches	20
7.2	Mounting the body cover	21
7.3	Starting	21
8	Emergency operation (manual override)	22
9	Faults	23
9.1	Fault causes	23

Content

10	Maintenance / Cleaning	24
10.1	Maintenance	24
10.2	Cleaning	24
11	Technical data	25
11.1	Dimensions RT20	26
11.2	Dimensions RT35	27
11.3	Wiring diagram	28
12	Index	29
13	Declaration of incorporation	30

1 Foreword

Dear customer,
Dear assembler / user,

These mounting and operating manual are intended to give you the knowledge which is necessary for you to be able to carry out the mounting and adjustment of an **actuator RT** rapidly and correctly.



Please read these instructions carefully and pay particular attention to the advice and warning notes!

The **actuators RT** are supplied in various versions, depending on the operating voltage and the output torque.

In case of the event of a power failure the output drive shaft of the **actuator RT** can be adjusted by the manual override.

The field of use of these actuators are predominantly

- in industrial fittings
- in chemical installations
- in ventilation and blower construction
- in heating and air-conditioning technology
- in machine and plant construction
- in water treatment, etc.

If you have any question in relation to the **actuator RT** we shall be pleased to answer them.

The telephone number will be found on the inside front cover of these mounting and operation manual.

Yours
END-Armaturen GmbH & Co. KG

2 General advice

2.1 Validity

The mounting and operating manual is valid for the standard versions of the electric **actuators RT**.

2.2 Inward monitoring

Please check directly after delivery the actuator for any **transport damage** and deficiency and with reference to the enclosed **delivery note** the number of the parts.

Do not leave any parts in the package.

2.3 Complains

Claims for the replacement of goods which relate to transport damage can only be considered valid if the parcel service / forwarder has notified without delay.

In case of returns (because of transport damage / repairs), please make a damage protocol and send the parts back to the manufacturer, if possible in the original packaging.

In case of a return, please mention the following:

- Name and address of the consignee
- Ordering- / Article- number
- Description of the defect.

2.4 Guarantee

For our **actuators RT** we give a guarantee period in accordance with the sales contract. The end of the normal duration of life of the wearing parts represents no defect.

The warranty and guarantee rules of **END-Armaturen GmbH & Co. KG** are applicable.

2.5 Symbols and their signification



Paragraphs which are identified with this symbol contain very important advices, this also includes advices for averting health risks. Observe this paragraphs without fail!



Paragraphs which are identified with this symbol contain important advices, this also includes how to avoid damage to property. Observe these paragraphs without fail!



This symbols indicates paragraphs which contain comments / advices or tips.



This spanner identifies the description of actions which you should carry out.

3 Safety advice

Depending on the technical circumstances and the time under and at which the electric actuator is mounted, adjusted and commissioned, in each case you have to take into account particular safety aspects

If, for example, the actuator actuates a slide in an operational chemical plant, the potential hazards of commissioning have another dimension from that when this is only being carried out for test purposes on a „dry“ part of the plant in the assembly room.

Since we do not know the circumstances at the time of mounting / adjusting / commissioning you may find advice on hazards in the following description which are not relevant to you. Please observe (only) the advice which applies to your situation!



The actuators must not be put into service until the final machinery into which it is to be incorporated has been declared in conformity with the provisions of the Directive 2006/42/EC on machinery, where appropriate.

3.1 Personal protection

3.1.1 Safety advice for mounting



We wish to point out expressly that the mounting, the electrical installation and the adjustment of the actuator RT and the accessories must be carried out only by trained specialised personnel having mechanical and electrical knowledge.



**Switch off all the devices / machines / plant affected by mounting or repair.
If appropriate, isolate the devices / machines / plant from the mains.**



Check (for example in chemical plants) whether switching off the devices / machines / plant will cause potential danger.



If appropriate, in the event of a fault in the actuator (in a plant which is in operation), inform the shift foreman / safety engineer or the works manager without delay about the fault, in order, for example, to avoid an outflow / overflow of chemicals or the discharge of gases in good time by means of suitable measures.



Before mounting or repair, remove the pressure from the pneumatic / hydraulic devices / machines / plant.



If necessary, set up warning signs in order to prevent the inadvertent starting up of the devices / machines / plant.



Observe the respective relevant professional safety and accident prevention regulations when carrying out the mounting / repair work.



Check the correct functioning of the safety equipment (for example the emergency push off buttons / safety valves, etc).



Before the electrical installation of the actuator, check the voltage-free state of all lines to be connected.

3.1.2 Safety advice for adjustment and starting



As a result of the starting (electrically or by hand) of the actuator, the position of a slide / valve / flap or the like on which it is flange-mounted - referred to below as the actuating element - will be changed!

As a result, the flow of gases, steam, liquid, etc. may be enabled or interrupted.



Satisfy yourself that, as a result of the starting or the test adjustments on the actuator, no potential hazards will be produced for personnel or the environment!



If necessary set up warning signs in order to prevent the inadvertent starting up or shutting down of the devices / machines / plant!



After completing the adjustment, check the correct function and, if appropriate, compliance with the intended angular position of the actuator and the function of the switches of the adjusted to the angular positions!



Check the function of the end position switches.



Check whether the actuating element is actually 100 per cent closed when the controller signals the corresponding end stop.



Through suitable measures, prevent that limbs being trapped by moving actuating elements!



Check the correct function of the safety devices (for example emergency push off buttons / safety valves, etc.



Carry out the starting or the adjustment only in accordance with the instructions described in this documentation!



In case of adjustments on an actuator which is open and switched on (ready to use), there is a risk that live parts can be touched.



In case of an actuator which is open and ready to operate, when tools are being used (for example small screwdrivers, forceps, etc.) there is the risk that you may touch live parts (up to 230V AC) and thus receive a shock.

3.2 Device safety

The electric **actuator RT**

- is a quality product which is produced in accordance with the recognized industrial regulations
- and which has left the manufacturers work in a perfect safety condition.



In order to maintain this condition, as installer / user you must carry out your task in accordance with the descriptions of these instructions, technically correctly and with the greatest possible precision.



We assume that you have, as a trained specialist, sound mechanical and electrical knowledge!

The actuator must be used only for the purpose corresponding to its construction.



The actuator must be used only within the values specified in the technical data.

Fuse the electric actuator with appropriate fuses or motor protective switches according to the power consumption.



Satisfy yourself that, as a result of the mounting, the starting or as the result of the test adjustments on the actuator, no potential hazards will be produced for devices / machines / plant!



Open the actuator only to such an extent as described in this documentation!



Do not mount the actuator, start the actuator or carry out any adjustments on it, if the actuator, the supply lines or the part of the plant on which the it is flange-mounted is damaged!



Before mounting the actuator, check the free running of the actuating element.



Before the electrical installation of the actuator, check that all the lines to connected are voltage-free.



After completing the mounting or the adjustments, check the correct function and, if appropriate, compliance with the intended angular position of the actuator and also the function of the switches adjusted to the angular positions.



Do not use any abrasive, caustic or flammable cleaning aids for cleaning the housing, or any high-pressure cleaning devices.

4 Device description

4.1 Device description RT

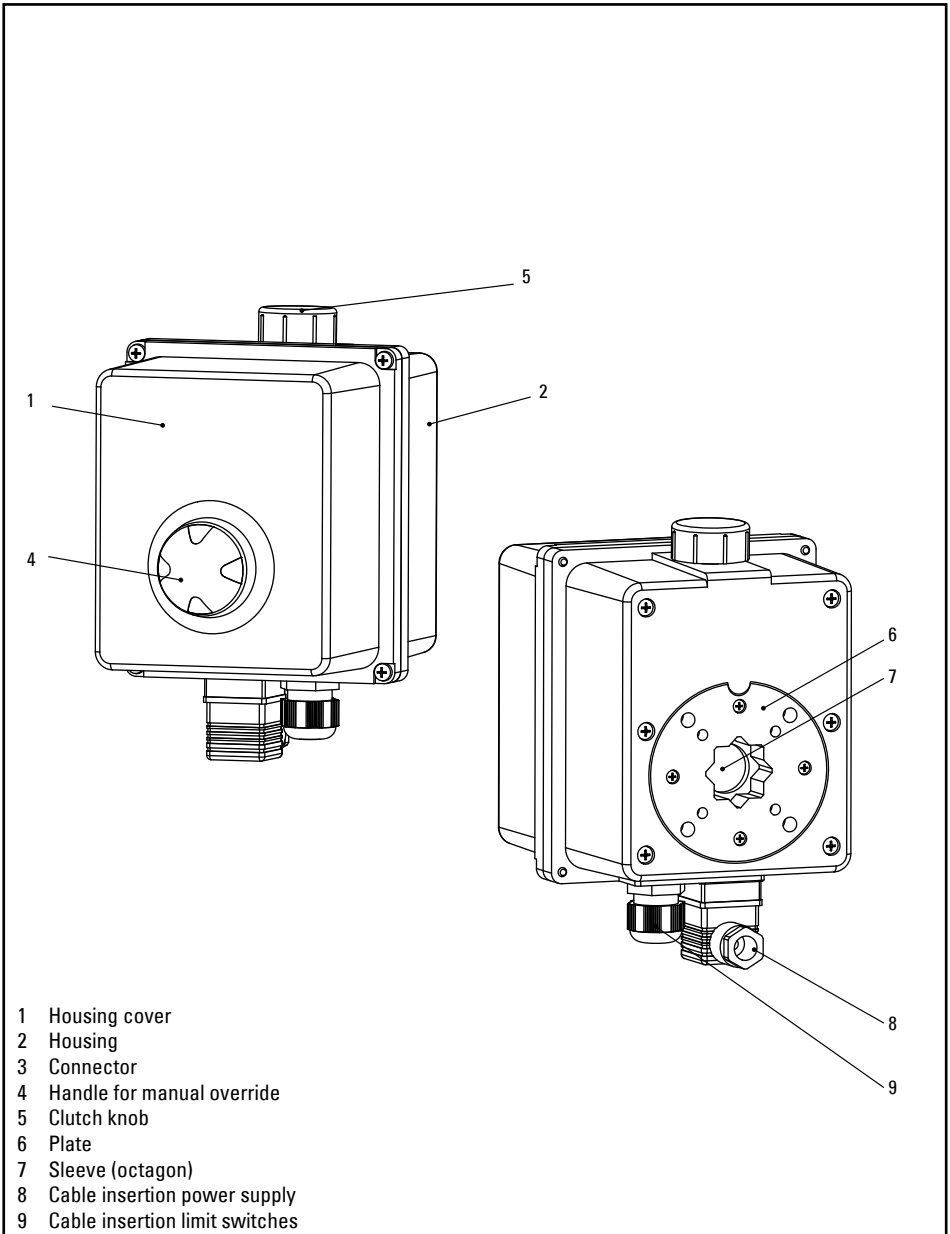

- 1 Housing cover
- 2 Housing
- 3 Connector
- 4 Handle for manual override
- 5 Clutch knob
- 6 Plate
- 7 Sleeve (octagon)
- 8 Cable insertion power supply
- 9 Cable insertion limit switches

Fig. 4.1 - RT Front-/ Rearside

Device variants

4.2 Device variants

Ordering example: e.g. RT201110

= Electric actuator, torque 20 Nm, 7s operating time (90°), 24V 50/60Hz, with 2 additional limit switches

1.+ 2. Digit Product	3.+ 4. Digit Type	5. Digit	6. Digit Voltage	7. Digit Options	8. Digit
RT = Electric actuator	20 = 20Nm 35 = 35Nm	1 = internal number	1 = 24V AC 2 = 24V DC 3 = 115V AC 4 = 230V AC	0 = without 1 = 2 additional limit switches	0 = reserved for mounting on valves

4.3 Name-plate

The actuators will be provided with a name-plate, which permits a definite identification of the actuator and shows the most important technical data to you. The name-plate should not be displaced or changed.

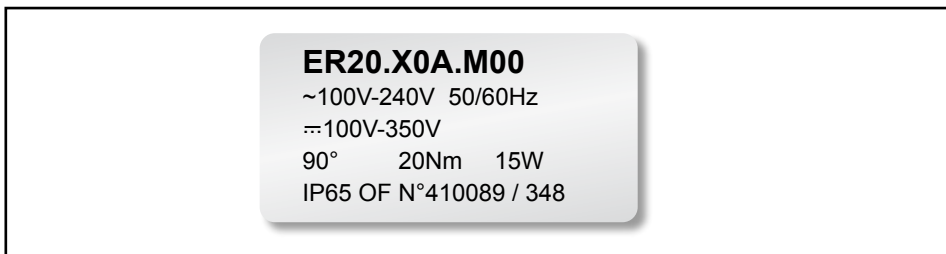

Fig. 4.2 - Name-plate

ER20.X0A.M00

~ 100V-240V 50/60Hz

≡ 100V-350V

90°

20Nm

15W

IP65

Type of the electric actuator
(not identical to the ordering number)

nominal voltage of the actuator

rotation angle of the actuator

nominal torque of the actuator

nominal power consumption of the actuator

protection according to EN 60529

5 Ambient conditions

The actuators RT are designed for normal operating conditions. The actuators RT have the enclosure IP65 acc. to EN 60529.

However, some special conditions are to be observed for its mounting and subsequent operation.

Take care that



- the actuator won't be placed "head down".
- the actuator will be mounted in accordance with the mounting advice listed below.
- the actuator is used in accordance with the characteristic values specified on the name-plate or in the separate data sheet.



The non-observance of the mounting advice or use outside the specified characteristic values can have a negative influence on the functional reliability of the actuator.

6 Assembly instructions

The mounting of the actuator RT is restricted to

- the mechanical mounting of the actuator on the part of the devices / machines / plant which contains the actuating element, and
- the connection of the actuator to the motor drive and control lines.



In the following description, we assume that you have carefully read the previous chapter and that you will observe the safety advice and the warning notes in chapter 3 during the mounting / disassembly work.



If you have not yet read chapter 3 „safety advice“ please do so now and then return to this point!

The mounting and the electrical installation may be carried out only by trained specialist personnel with sound mechanical and electrical knowledge.



The **mechanical mounting** and the **electrical installation** is nearly identical in all variants.

6.1 Mechanical mounting

6.1.1 Mounting of the removable plate (only RT20xx)



Insert the o-ring sealing between the shaft and the housing of the actuator. Observe the correct position of the o-ring, it will sealed between the shaft and the body of the actuator.



Insert the fit nuts for your chosen hole cycle into the backside of the removable plate. (hole cycle F03 + F04: nut M5; hole cycle F05: nut M6).



Fit the removable plate at the housing of the actuator with the enclosed screws according to the figure. Tighten the screws.



Because of the removable plate the actuator RT will be fix on the armature with the hole cycle F03, F04 or F05. Would there be two sizes of hole circles to fasten the actuator, you have always to use the greater one.

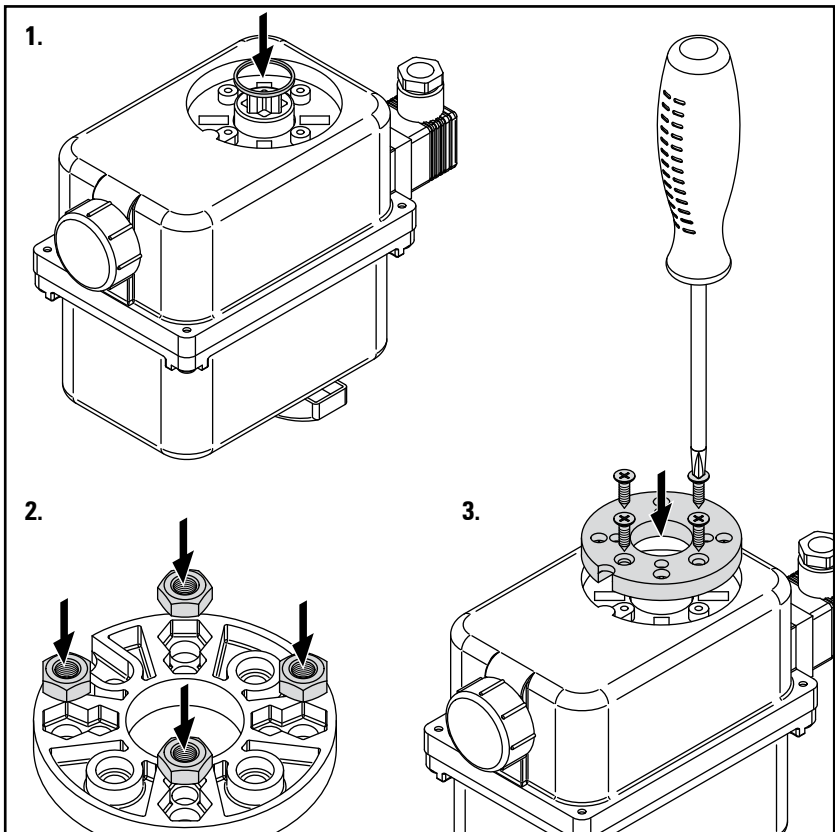









Fig. 6.1 - Mounting of the removable plate

6.1.2 Mounting of the actuator / actuating element

-  Observe that the actuator and the actuating element are in CLOSE position.
-  Move the actuator with the rear side against the part of the devices / machines in such a way that the stem of the actuating element ingress into the opening output drive shaft. If necessary use a reducer (options), to equalize differences of the dimension between the stem and the shaft.
-  Reducer from octagon 14mm to square 11mm respective square 9mm at RT20 and reducer from octagon 22mm to square 17mm at RT35 are in the accessory bag of the actuators.
-  Adjust the actuator to the actuating element.
-  Push the actuator so far towards to the mounting position that it is rests flat on the fastening surface. Don't bang onto the actuator body.
-  Fix the actuator with applicable screws. Observe the position of the inserted nuts of the removable plate (only RT20xx). Would there be two sizes of hole circles to fasten the actuator, you have always to use the greater one.
-  Tighten the screws. Observe the maximum torque of the selected screws.

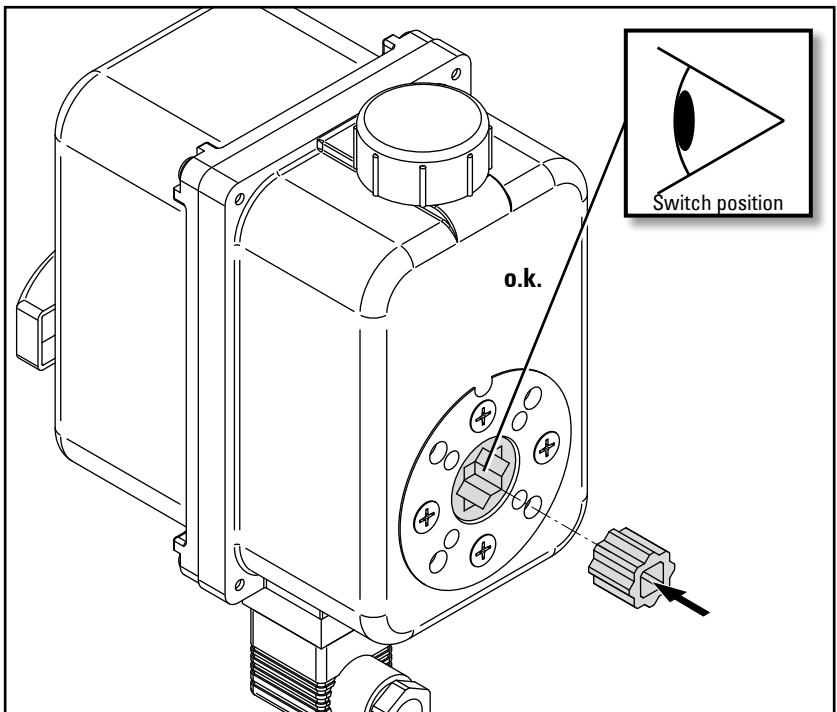

Fig. 6.2 - Mounting actuator / device

6.2 Electrical installation



At actuators which are ready mounted onto a valve at the factory the limit switches are already adjusted and the actuators are tested. If you want to connect at these actuators only the power supply without additional limit switch monitoring the dismantling of the actuator cover is not necessary.

6.2.1 Dismounting of the actuator cover



Move off the handle (RT20xx) respectively the optical position indicator (RT35xx) in case these parts are mounted.



Notice the position of the handle respectively of the optical position indicator on the stem for the remounting.



Loose the four screws with a suitable cross tip screwdriver and move off the actuator cover carefully.



If you use a screwdriver for assistance put it only some millimetres and in the area of the screws between actuator body and cover.



Do not damage the cover and/or the sealing rubber in the process. In this case, the degree of protection would no longer be ensured and moisture and pollution can come into the internal side of the actuator.

6.2.2 Connecting of the power supply and the limit switches



Take care that all leads which have to be stripped and connected during the installation work have all their poles isolated from the power supply.

When stripping leads which are live, there is a risk of a life-threatening shock.

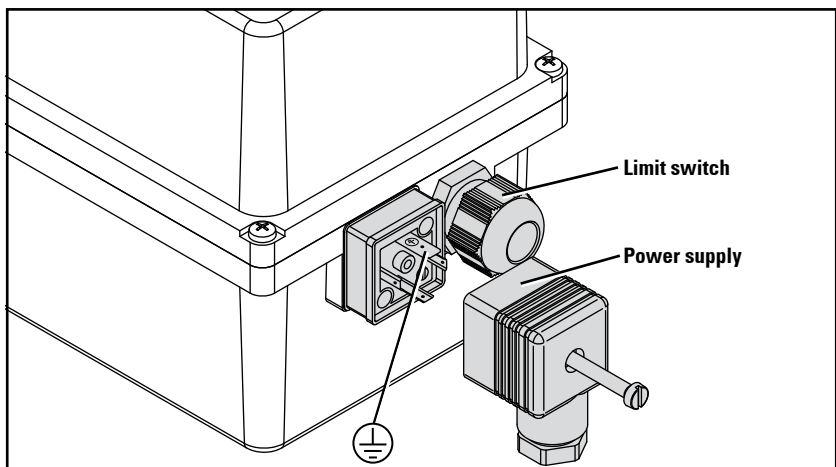







Fig. 6.3 - Power and remote connecting

 The connection of the power supply will happen over the connector at the outside of the actuator, the connection of the limit switches will happen by the terminal in the inside of the actuator.

 Remove the sheaths of the motor drive cable and the control cable and the insulation from the leads.

 In the case of leads with stranded conductors, provide the ends in each case with a wire end sleeve.

 Lead the cable for the motor and the cable for the limit switches through the cable entries.

 Feed the stripped ends of the leads into the terminals as far as the stop and then tighten them. The assignment of the connections can be seen from the wiring diagrams at the cover of the actuator or at the end of these mounting and operation manual.

 **Please be sure that the voltage of the power supply is in accordance with the specification of the name-plate. Don't miss to connect the ground earth.**

Ensure that no bare wires protrude from the terminals and thus produce the risk of a shock or of a short circuit.

 Tighten the cable entries so firmly that the strain relief becomes effective and the cables lead through correspond to the predefined degree of protection.

 Fit the power supply connector at the connector plate at the actuator. Observe the right position of the sealing.

 If you don't connect the limit switches, close the cable entry of the limit switch with a suitable plug to prevent an ingress of moisture and pollution into the internal side of the actuator.

 Bend the leads in the actuator such that they are not trapped when the housing cover is fitted.

 Lay the cables to their starting positions (as appropriate, in conduits or cable ducts).

 Observe that no moisture reach along the cable into the actuator. Lead the cable in an elbow that potentially water can drip down.

 Ensure that the cables are not crushed or sheared and that they are not under pressure or tension.

 **Do not lay the control cable parallel to other cables which lead to high-power loads. Powerful electromagnetic fields could induce currents in the control lines which may possibly lead to malfunctions.**

 Finally, carry out the adjustments to the actuator and close the cover of the actuator again. For this please observe chapter

→ 7 „Adjustment / Starting“

6.3 Disassembly

Although the disassembly of an actuator in principle proceeds in the reverse sequence to the mounting, some essential points should be clarified before.

Will the actuator to be disassembled be replaced immediately by another?
If not, in which position should the actuating element be following the disassembly?

Must the actuating element be fixed in its intended position?



If appropriate, does the production process of the plant need to be stopped?

Is it necessary to inform specific personnel about the disassembly?

6.3.1 Electrical disassembly



Using the actuator to rotate the actuating element into the intended position!

Switch off all the poles of the power supply and the controller of the actuator.



If necessary, set up warning signs in order to prevent

- **the inadvertent starting up of the part of the devices / machines / plant which is affected by the disassembly, or**
- **the switching on of the power supply / the controller of the actuator.**



Loosen the screws of the connectors and pull off the connectors from the actuator.



Loosen the screws of the terminals and pull the leads out of the terminals.



Loosen the metric screw fittings and pull the cables out of the device.



Insulate the bare lead ends if the cables are not also being disassembled or are not to be immediately reconnected to another actuator.

6.3.2 Mechanical disassembly



Unscrew the four fastening screws of the actuator and pull off the actuator from the mounting position.

7 Adjustment / Starting

Before you open the actuator, make adjustments by hand or start operating it you must have read chapter:



➔ 3 „Safety advice“

If you have not yet done this, read this important advice now and then return to this point of manual.



Ensure that no liquid, moisture or any foreign bodies (sand, dust or the like) get into the open actuator.

The following descriptions are based on the assumption that the actuator is installed on the device or the part of the plant which contains the actuating element.

If appropriate, please observe chapter



➔ 6 “Mounting / disassembly”

on this point.

In order to carry out the adjustments

- you must remove the housing cover. On this point, see

➔ 6.2.1 “Removing the housing cover”

- it is necessary to move the output drive shaft and , as a result, the actuating element and the cam disc. This can be done both via the electric drive and via the hand adjustment. In the following text, we will describe the electric method. The manual adjustment of the actuating element is explained under

➔ 8 “Emergency operation”

7.1 Adjustments



Please turn to the wiring diagram at the end of these instructions. There you will find the components and terminals listed in the description.



Before you make adjustments to or changes to the settings on actuators which are installed in plants that are ready to operate, please find out whether (for example applying the motor drive voltage (power supply) for left / right operation) will influence further actuators or whether closing / opening microswitches will trigger (mal-)functions of other devices.



Ensure that no (mal-)functions of further parts of the plant will be triggered by these adjustments or changes (for example by disconnecting lines or by changes to cabling).



For the adjustments described below, in each case apply the motor drive voltage (power supply) to the terminals of the actuator only until the intended rotational movement has been carried out, and then isolate all the poles of the power supply from the terminals again.

7.1.1 Adjustment of the limit switches



In case of an actuator which is open and ready to operate, when tools are being used (for example small screwdrivers, forceps, etc.) there is the risk that you may touch live parts (up to 230 V AC) and thus receive a shock.



Drive the actuator into the desired position.



Adjust the according cam until the cam operates the respective limit switch. The cam can be rotate on the camshaft by using a small screwdriver or wrench.



Observe that you don't slip off with the tools. Injuries or damages of internal parts of the actuator can be the following.



Replicate the above procedure for the second switching position.



Check the right positions of the switching cams and the function of the limit switches by electrical driving to both end positions.

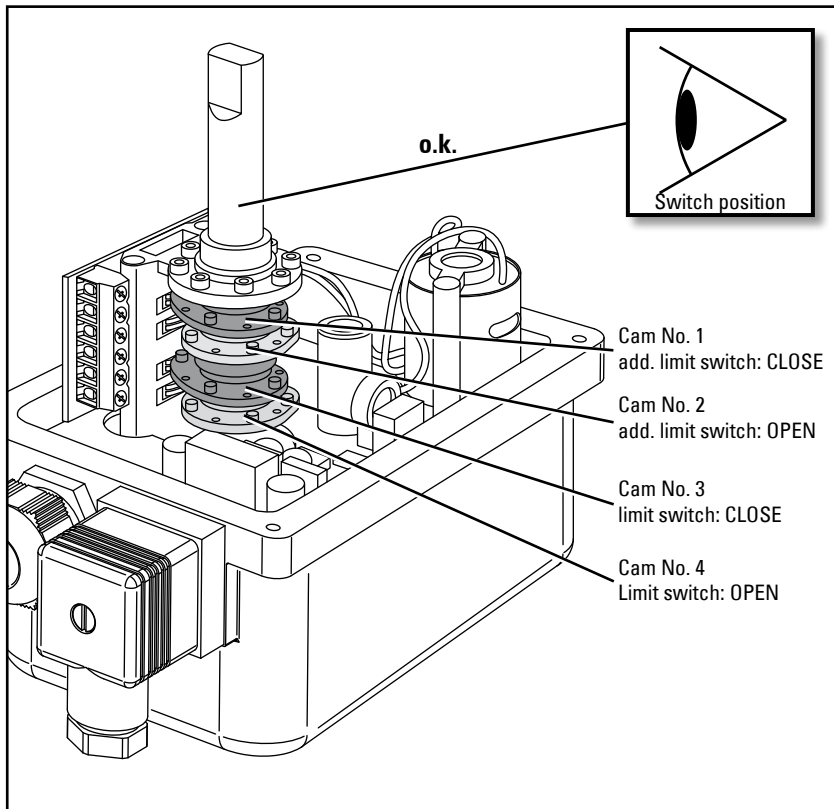

Fig. 7.1 - Adjustment of the limit switches

7.2 Mounting the body cover



Before you mount the housing cover onto the actuator, check whether

- the switching cams of the limit switches are set correctly.
- **the actuating element is actually 100 percent closed when the controller indicates the corresponding end stop.**
- the connecting leads are correctly screwed tightly in the terminals.



Ensure that the leads are not trapped between the housing and the housing cover and that the circumferential rubber sealing ring in the housing and the sealing ring of the camshaft is not damaged and correctly seated in the groove.



Place the housing cover onto the actuator. Tighten the four screws of the housing cover by using a cross tip screwdriver.



Attention! The maximum torque of the body screws are 0,5Nm!



Put the handle (RT20xx) respectively the optical position indicator (RT35xx) onto the camshaft.



The position of the actuating element can be indicated by the yellow plastic caps. Push these caps into the desired positions at the handle respectively the optical position indicator.

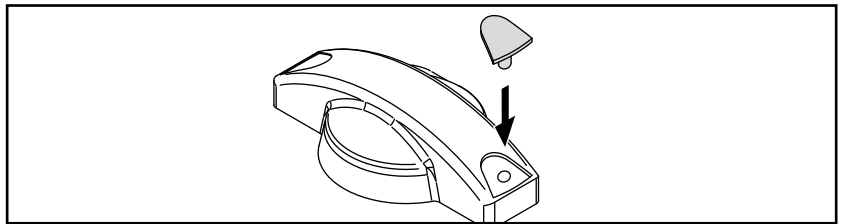

Fig. 7.2 -Setting the plastic caps of the optical position indicator

7.3 Starting



Before you start the actuator you must have read the chapter

➔ 3 „Safety advice“

If you have not yet done so, read this important advice now and then return to this point of the manual.

The starting of an actuator which is mounted on a plant that is ready to operate (for example in a refinery or in a plant in the chemical industry) must be carried out

- **only in compliance with the plant-specific regulations**
- **only after the adjustments / operation described in sections**



➔ 7.1 „Adjustments“

have been carried out.



Drive the actuator via the controller or by hand and check the correct functioning of the actuator, the limit switches and the actuating element.

8 Emergency operation (manual override)

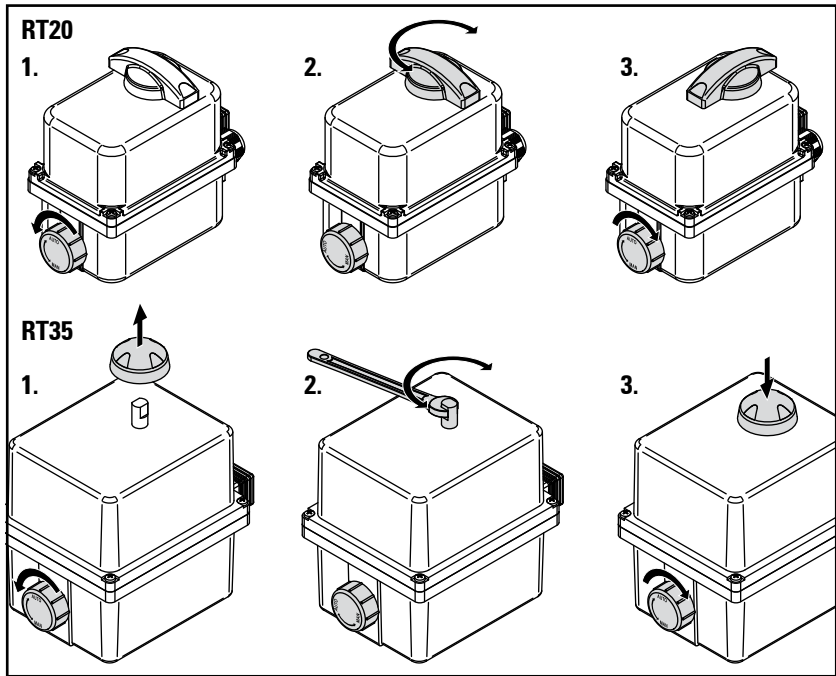

Fig. 8.1 - Manual override



Be sure that the power supply is switched off, before using the manual override

In the case of power or controller failure or a fault in the actuator, in order to be able to adjust the actuating element in an emergency, the actuator has the capability for manual adjustment.



If necessary, inform the shift foreman / safety engineer or the works manager about the disturbance without delay in order, for example, to avoid an outflow / overflow of chemicals or a discharge of gases in good time by means of suitable measures.



To operate the manual override turn the clutch knob from AUTO to MAN and lock the knob into this position by hand.



Turn the shaft of the actuator by using the handle (RT20xx) or by using a fit spanner (RT35xx).



The actuator will return to the AUTO mode by turning the clutch knob to the AUTO position.



Observe the position indicator at the handle or switching shaft in order to detect the angular position of the actuating element.

9 Faults



If, during the test run or during operation, a functional fault of the actuator should occur, you are requested to carry out the adjustment to the actuating element (in an emergency) by hand. For this observe

➔ 8 „Emergency operation“



If necessary inform the shift forman / safety engineer or the works manger about the disturbance without delay in order, for example , to avoid an outflow / overflow of chemicals or a discharge of gases in good time by means of suitable measures.

Next using the following list, attempt to find the reason for the causes of the fault and if it lies within your capabilities, to correct this.

Do not, however, carry out any repairs on the actuator!



Isolate the defective actuator from the power supply!

In the event of a defect in the actuator, make contact with the manufacturer. The telephone number will be found on the inside front cover of these mounting and operation manual.

9.1 Fault causes

- Is the power supply to the actuator and to the controller switched on?
- Is the controller supplying the necessary signals?
- Are the leads from the controller to the actuator undamaged ?
- Is the actuator correctly flange-mounted to the actuating element ?
- Does the actuating element move freely?
- Are the end stop switching cams set correctly?
- Are the other switching cams set correctly?
- Is the position indicator adjusted correctly to the angular position of the actuating element?
- Are the leads in the terminal connected correctly and screwed tight?
- Can the actuating element be rotated into the end positions by means of the manual adjustment of the actuator?
- Is the fuse on the circuit board (only DC-version) intact?

10 Maintenance / Cleaning

10.1 Maintenance

The actuators of the series RT are maintenance free.

Check on an approximately six-monthly cycle, that the device is dry inside, at least after 1/2 year.

In the case of an actuator which is open and ready to operate, when tools are being used (for example small screwdrivers, forceps, etc.) there is the risk that you may touch live parts (up to 230V AC) and thus receive a shock.



In the event of a defect in the actuator, make contact with the manufacturer. The telephone number will be found on the inside front cover of these mounting and operating instructions.

Open the housing cover by loosening the 4 screws and pulling the housing cover hard to remove it. In this context, see:

➔ 6.2.1 „Removing the housing cover“



If you find moisture in the interior of the device, attempt to find the cause for this and eliminate it.

- Is the moisture condensation?
- Is the circumferential rubber sealing ring damaged?
- Do the metric screw fittings leak?
- Are there cracks in the housing or the housing cover?



If you determine that there is damage to the actuator, isolate the device from the power supply. However, before doing this, it is essential to refer to chapter:

➔ 3 „Safety advice“

10.2 Cleaning



Clean the housing of the actuator as required using a slightly moistened, soft cloth and a normal household cleaner.

Do not use any abrasive, corrosive or flammable cleaning agents.



Do not use any high-pressure cleaning devices.

Prevent moisture or liquid penetrating into the interior of the device.

11 Technical data

Actuator	RT20xx		RT35xx	
	24V	230V	24V	230V
Torque	20Nm		35Nm	
Operating time 90° rotation	7s ... 12s	9s ... 13s	6s ... 7s	7s ... 8s
Frequency	-	50/60Hz	-	50/60Hz
Power consumption	11W		45W	
Current consumption	0,5A (3A)	0,06A (4A)	1,9A (11,4A)	0,2A (13,5A)
Duty cycle	30%			
Ambient temperature	-10°C ... +55°C			
Protection	IP 65 acc. to EN 60529			
Contact rating limit switches	4 ... 250V AC/DC, 5A			
Body material	Plastic PA6.6 FV			
Cover material	Plastic ABS			
Mounting acc. to ISO 5211	F03, F04, F05		F05, F07	
Output shaft	Internal octagon 14mm		Internal octagon 22mm	
Weight	1,2kg		3,0kg	

11.1 Dimensions RT20

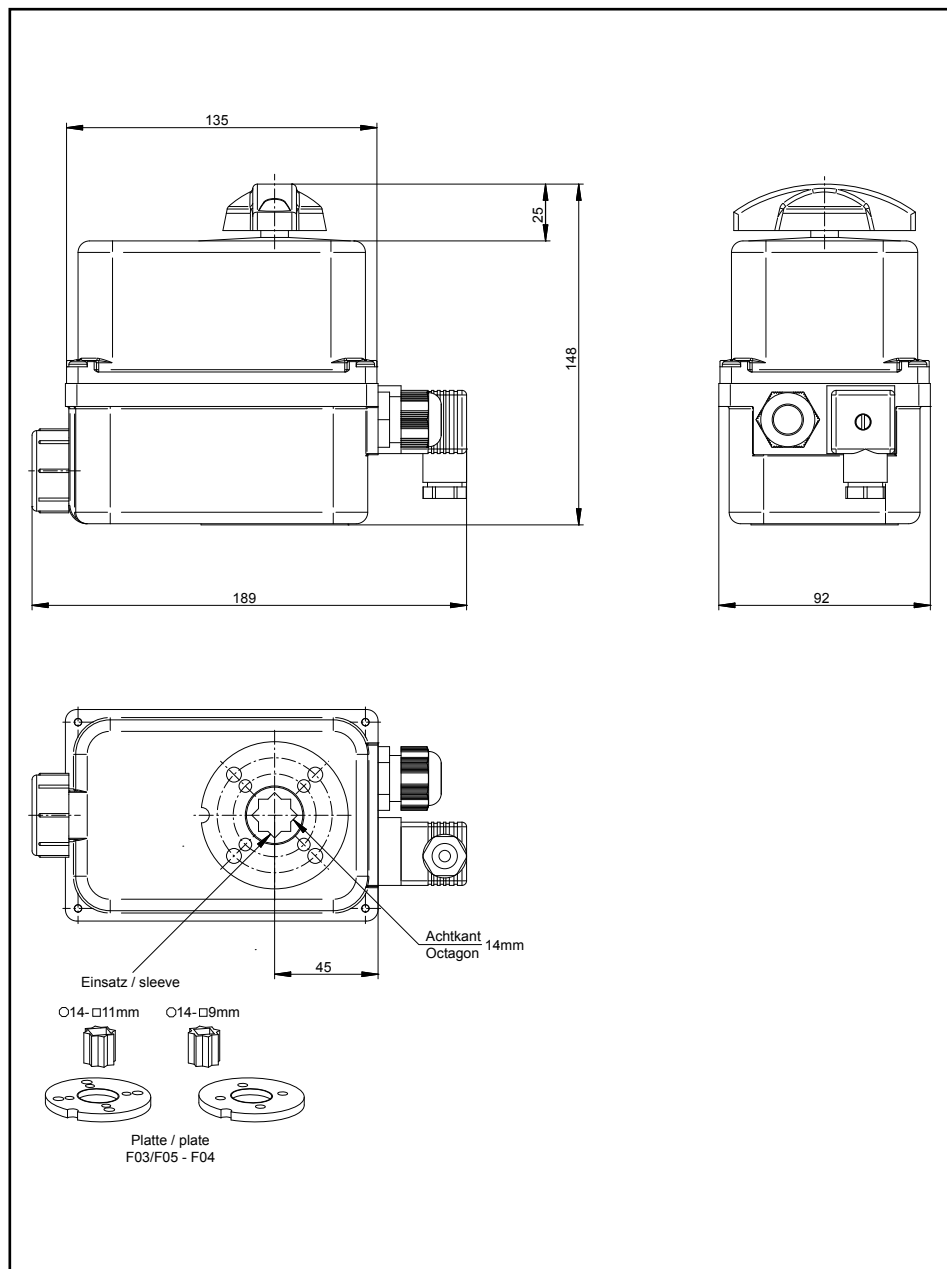

Fig. 11.1 - Dimension RT20

11.2 Dimensions RT35

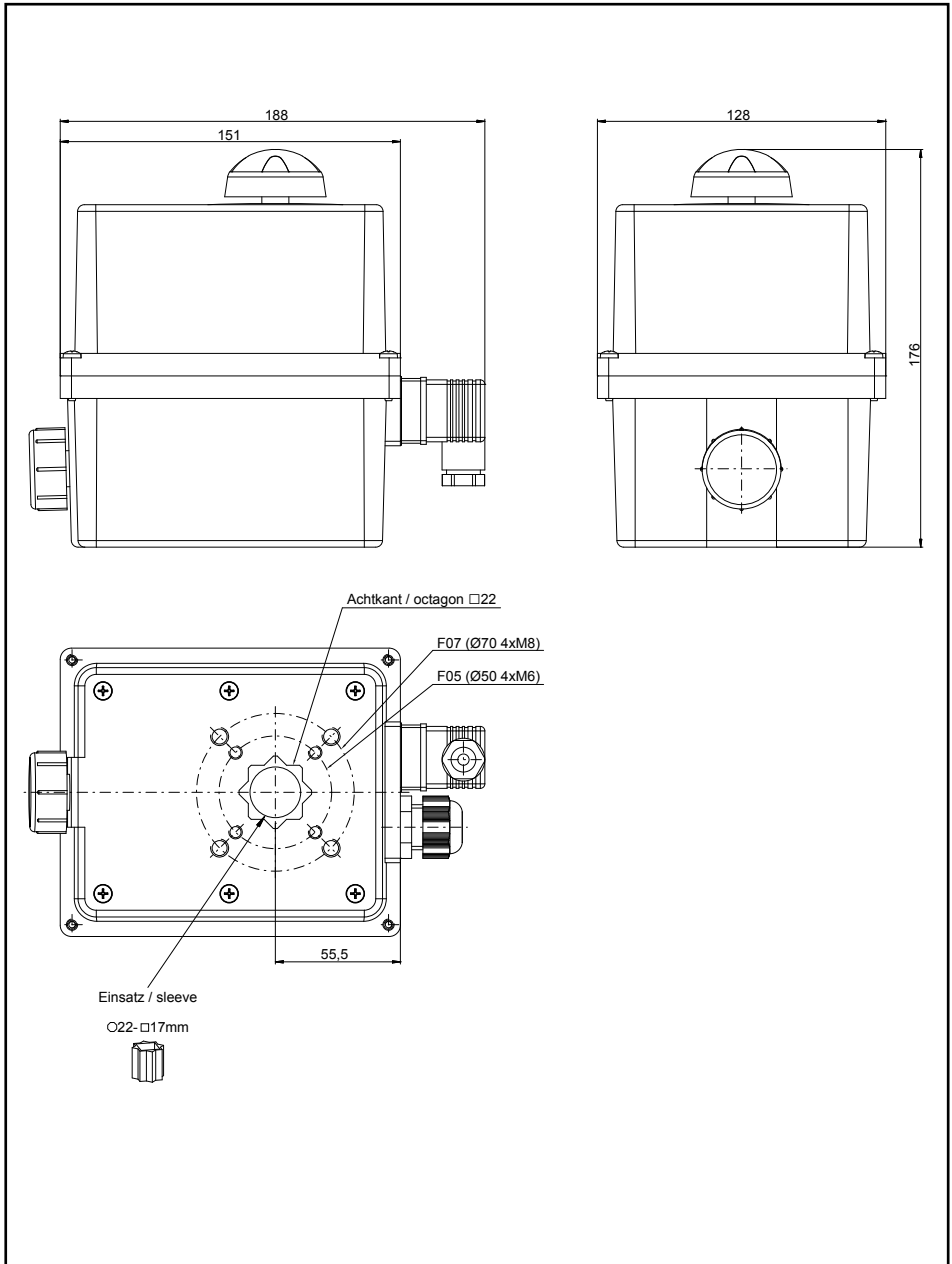

Fig. 11.2 - dimensions RT35

11.3 Wiring diagram

- FCO: Endlagenschalter 'AUF' / limit switch 'OPEB'
- FCF: Endlagenschalter 'ZU' / limit switch 'CLOSE'
- FC1: zus. Endlagenschalter 'AUF' / add. limit switch 'OPEN' (4V ... 250V AC/DC max. 5A)
- FC2: zus. Endlagenschalter 'ZU' / add. limit switch 'CLOSE' (4V ... 250V AC/DC max. 5A)

AUF-ZU Regelung OPEN-CLOSE control

24V DC, 24V AC
110V ... 240V 50/60Hz
100V ... 350V DC

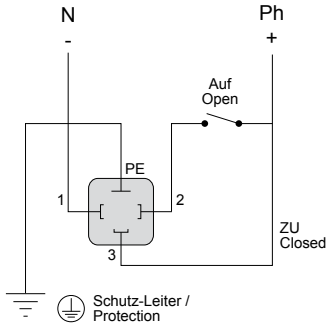

3-Punkt Regelung 3-point control

24V DC, 24V AC
110V ... 240V 50/60Hz
100V ... 350V DC

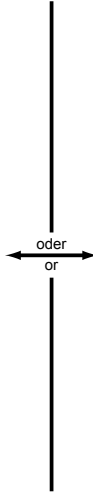
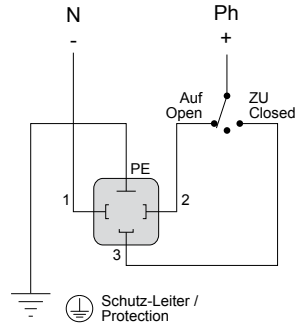

Zusätzliche Endschalter Aux. limit switches

4V ... 250V AC/DC max. 5A

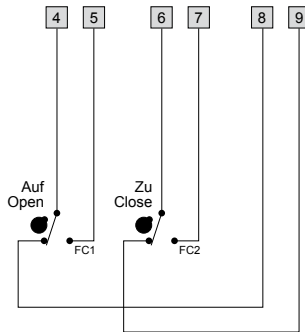

The wiring diagram shows the actuator in intermediate position, switches are not actuated.

12 Index

A

Adjustment of the limit switches20
 Adjustments19
 Adjustment / Starting.....19
 Ambient conditions13
 Ambient temperature25
 Assembly instructions.....13

B

Body material.....25

C

Cleaning24
 Complains6
 Connecting of the limit switches16
 Connecting of the power supply.....16
 Contact rating limit switches25
 Cover material25
 Current consumption.....25

D

Declaration of incorporation.....30
 Device description11
 Device safety10
 Device variants.....12
 Dimensions RT20.....26
 Dimensions RT35.....27
 Disassembly.....18
 Dismounting of the actuator cover16
 Duty cycle.....25

E

Electrical disassembly18
 Electrical installation.....16
 Emergency operation22

F

Fault causes23
 Faults23
 Foreword5
 Frequency.....25

G

General advice6
 Guarantee.....6

I

Imprint.....2
 Inward monitoring.....6

L

Line in voltage.....25

M

Maintenance.....24
 Manual override.....22
 Mechanical disassembly.....18
 Mechanical mounting14
 Mounting acc. to ISO 5211.....25
 Mounting of the actuator / actuating element.....15
 Mounting of the removable plate (RT20).....14
 Mounting the body cover.....21

N

Name-plate12

O

Operating time 90° rotation25
 Output shaft.....25

P

Personal protection8
 Power consumption.....25
 Protection.....25

S

Safety advice8
 Safety advice for adjustment and starting9
 Safety advice for mounting8
 Starting21
 Symbols and their signification7

T

Technical data.....25
 Torque.....25

V

Validity6

W

Weight.....25
 Wiring diagram.....28



Qualität von Anfang an.

(1) **Declaration of incorporation**
(2) **according to annex II of the Directive 2006/42/EC on machinery**

(3) This declaration apply to the electric :

Article	Description
RT20	Electric actuator, 20Nm
RT35	Electric actuator, 35Nm

and all variations of these articles

(4) of the company: **END-Armaturen GmbH & Co. KG** Documentation authorized: **Lars-Michael Rolfsmeier**
Oberbeckseener Str. 78
D-32547 Bad Oeynhausen
D-32547 Bad Oeynhausen

(5) Herewith we declare that the above mentioned actuators in the conditions of our delivery are partly completed machinery according to annex 2 paragraph g of the directive 2006/42/EC on machinery. These products have no CE marking because of this directive.

The relevant technical documentation is compiled in accordance with part B of annex VII.

The actuators are further in conformity with the regulations of the following directives:

Low Voltage Directive 2006/95/EC

DIN EN 61010-1: 2001 Safety requirements for electrical equipment for measurement, control and laboratory use - Part 1: General requirements

Directive on Electromagnetic Compatibility (EMC) 2004/108/EC

DIN EN 61000-6-2: 2005 Electromagnetic compatibility (EMC) - Part 6-2: Generic standards - Immunity for industrial environments

DIN EN 61000-6-4: 2007 Electromagnetic compatibility (EMC) - Part 6-4: Generic standards - Emission standard for industrial environments

DIN EN 61000-3-2: 2009 Electromagnetic compatibility (EMC) - Part 3-2: Limits - Limits for harmonic current emissions (equipment input current $\leq 16A$ per phase)

DIN EN 61000-3-3: 2008 Electromagnetic compatibility (EMC) - Part 3-3: Limits - Limitation of voltage changes, voltage fluctuations and flicker in public low-voltage supply systems, for equipment with rated current $\leq 16A$ per phase and not subject to conditional connection

(6) In response to a reasoned request the national authorities can demand the relevant information on the partly completed machinery. The transmission takes place by post or e-mail.

(7) The partly completed machinery must not be put into service until the final machinery into which it is to be incorporated has been declared in conformity with the provisions of the Directive 2006/42/EC on machinery, where appropriate.

(8) Bad Oeynhausen, 29. October 2010, on behalf:



END-Armaturen GmbH & Co. KG
Oberbeckseener Str. 78
32547 Bad Oeynhausen · Germany
Telephone: +49 (0)5731 - 7900-0
Telefax: +49 (0)5731 - 7900-199
<http://www.end.de> · post@end.de

Friedhelm König

Declaration without signature or company stamp shall not be valid. The declaration may be circulated only without alternation. Extracts or alternations are subject to approval by END-Armaturen GmbH & Co. KG.



END-Armaturen GmbH & Co. KG



Qualität von Anfang an.

Qualität von Anfang an.

END-Armaturen GmbH & Co. KG

Oberbecksener Str.78
 D-32547 Bad Oeynhausen
 Postfach (PLZ 32503) 100 341
 Telefon +49 (0) 5731 / 7900-0
 Telefax +49 (0) 5731 / 7900-199
 Internet <http://www.end.de>
 E-Mail post@end.de

END-Automation GmbH & Co. KG

Oberbecksener Str.78
 D-32547 Bad Oeynhausen
 Postfach (PLZ 32503) 100 342
 Telefon +49 (0) 5731 / 7901-0
 Telefax +49 (0) 5731 / 7901-999
 Internet <http://www.end.de>
 E-Mail post@end.de

Watergates GmbH & Co. KG

Oberbecksener Str.70
 D-32547 Bad Oeynhausen
 Postfach (PLZ 32503) 100 321
 Telefon +49 (0) 5731 / 7900-0
 Telefax +49 (0) 5731 / 7900-199
 Internet <http://www.watergates.de>
 E-Mail post@watergates.de

ISO 9001
 97/23/EG
BUREAU VERITAS
 Certification



N° INT0209DE