

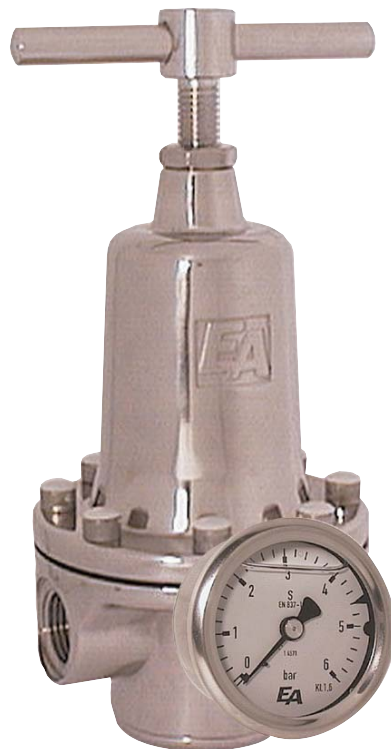

Qualität von Anfang an.

Pressure Reducer Operation and Installation Manual



© by **END-Automation GmbH & Co. KG**

All rights reserved. No part of this publication may be copied or published by means of printing, photocopying, microfilm or otherwise without prior written consent of **END-Automation GmbH & Co.KG**. This restriction also applies to the corresponding drawings. **END-Automation GmbH & Co. KG** has the right to change parts of the valves at any time without prior or direct notice to the client. The contents of this publication are subject to change without notice.

This publication has been written with great care. However, **END-Automation GmbH & Co. KG** cannot be held responsible, either for any errors occurring in this publication or for their consequences.

The products are specified by the statements in this documentation; no assurance of the properties is given.

END-Automation GmbH & Co. KG
Oberbecksener Straße 78
D-32547 Bad Oeynhausen
Telefon: 05731 / 7901 - 0
Telefax: 05731 / 7901 - 999
Internet: <http://www.end.de>
E-Mail: post@end.de

Ausgabedatum: 10/10

Contents

1	Foreword	4
2	General advice	5
2.1	Validity	5
2.2	Inward monitoring	5
2.3	Complaints	5
2.4	Guarantee	5
2.5	Symbols and their Signification	6
3.	Safety advice	7
3.1.	Personal protection	7
3.1.1.	Safety advice for mounting	7
3.1.2	Safety advice for adjustment and starting	8
3.1.3	Safety advice for maintaining / repairing	8
3.2	Device safety	9
4	Name-plate	10
5	Pressure reducer	11
5.1	General	11
5.2	Corresponding use	11
5.3	Operation	11
5.4	Mounting / Disassembly	12
5.4.1	Mounting with threaded connection	12
5.4.2	Mounting with screw pipe connection	13
5.4.3	Mounting with welded connection	14
5.4.3.1	Disassembly of the pressure reducer	14
5.4.3.2	Welding of the body between two pipes	15
5.4.3.3	Mounting of the pressure reducer	15
5.4.4	Mounting with flanged connection	16
5.5	Maintenance	17
5.5.1	Cleaning of the mesh (only Art. MB and SD)	17

1 Foreword

Dear customer,
Dear assembler / user,

these operation and installation manuals are intended to give you the knowledge which is necessary for you to be able to carry out the mounting and adjustment of an pressure reducer rapidly and correctly.



Please read these instructions carefully and pay particular attention to the advice and warning notes.

Only instructed and qualified mechanician should mount, adjust or maintain the pressure reducer.

If you have any questions in relation to the pressure reducer, we shall be pleased to answer them.

The telephone number will be found on the inside cover of these operation and installtion manual.

Yours
END-Automation GmbH & Co. KG

2 General advice

2.1 Validity

This mounting and installation manual is valid for the standard version of the pressure reducer.

2.2 Inward monitoring

Please check

- directly after delivery the pressure reducer for any transport damages and deficiencies
- with reference to the accompanying delivery note the number of parts.

Do not leave any parts in the package.

2.3 Complaints

Claims for replacement of goods which relate to transport damage can only be considered valid if the delivery company is notified without delay.

In case of returns (because of transport damage/repairs), please make a damage protocol and send the parts back to the manufacturer, if possible in the original packaging.

In case of return, please mention the following:

- Name and address of the consignee
- Stock-/ordering-/article-number
- Description of the defect

2.4 Guarantee

For our pressure reducer we give a guarantee period in accordance with the sales contract.

The warranty and guarantee rules of **END-Automation GmbH & Co. KG** are applicable.

2.5 Symbols and their Signification



Paragraphs which are identified with this symbol contain very important advices; this also includes advices for averting health risks.
Observe these paragraphs without fail!



Paragraphs which are identified with this symbol contain very important advices; this also includes how to avoid damage to property.
Observe these paragraphs without fail!



This symbol indicates paragraphs which contain comments/advice or tips.



This bullet identifies the description of actions which you should carry out.

3. Safety advice

Depending on the technical circumstances and the time under and at which the pressure reducer is mounted, adjusted and commissioned, you must in each case take into account particular safety aspects!

If, for example, the pressure reducer works in an operational chemical plant, the potential hazards of commissioning have another dimension from that when this is only being carried out for test purposes on a „dry“ part of the plant in the assembly room.

Since we do not know the circumstances at the time of the mounting/adjustment/commissioning, you may find advice on hazards in the following descriptions which are not relevant to you .

Please observe (only) the advice which applies to your situation!

3.1. Personal protection

3.1.1. Safety advice for mounting



We wish to point out expressly that the mounting, the electrical installation and the adjustment of the pressure reducer and the accessories must be carried out only by trained specialist personnel having mechanical and electrical knowledge!



**Switch off all the devices / machines / plant affected by mounting or repair.
If appropriate, isolate the devices / machines / plant from the mains.**



Check (for example in chemical plants) whether the switching off of devices / machines / plant will cause potential danger.



If appropriate, in the event of a fault in the pressure reducer (in a plant which is in operation) inform the shift forman / safety engineer or the works manager without delay about the fault, in order, for example, to avoid an outflow / overflow of chemicals or the discharge of gases in good time by means of suitable measures!



Before mounting or repair, remove the pressure from pneumatic / hydraulic devices / machines / plant.



Empty the conduit from medium.



If necessary, set up warning signs in order to prevent the inadvertent starting up of the devices / machines / plant.



Observe the respective relevant professional safety and accident prevention regulations when carrying out the mounting / repair work.



Check the correct functioning of the safety equipment (for example the emergency push off buttons/ safety valves, etc)!

3.1.2 Safety advice for adjustment and starting



As a result of the starting of a pressure reducer the flow of gases, steam, liquids, etc. may be enabled or interrupted!



Satisfy yourself that, as the result of the starting or the test adjustments of the pressure reducer, no potential hazards will be produced for the personnel or the environment!



If necessary, set up warning signs in order to prevent the inadvertent starting up or shutting down of the devices / machines / plant.

By ending mounting check the correct function and the tightness of the valve.



Check the right function of all safety devices (for example emergency off push buttons / safety valves, etc.)!



Carry out the starting and the adjustments only in accordance with the instructions described in this documentation!

3.1.3 Safety advice for maintaining / repairing



Do not carry out any maintenances / repairs if the pressure reducer will be under pressure.

Before disassembling a pressure reducer some essential points should be clarified!

- Will the pressure reducer to be disassembled be replaced by another immediately?
- If appropriate, does the production process of the plant needed to be stopped?
- Is it necessary to inform specific personnel about the disassembly?



If necessary, inform the shift foreman/ safety engineer or the manager about the maintenance or repair without delay in order, for example, to avoid an outflow/ overflow of chemicals or a discharge of gases in good time by means of suitable measures.



Switch off pilot pressure and the power supply and relieve the pressure in the pipes.

If necessary set up warning signs in order to prevent

- the inadvertent starting up of the devices/machines/plants in which the pressure reducer is mounted
- the switching on of pilot medium supply, pilot power supply and/or the power supply of actuators and accessories.



In case of defect in the pressure reducer make contact to the supplier. The telephone number will be found on the back cover of these mounting and installation manual.



If you ascertain a damage of the pressure reducer, isolate the device from the mains. Please observe the safety advices.



Do not mount, start or adjust the pressure reducer if itself, the pipes or a mounted actuator will be damaged.

3.2 Device safety

The pressure reducers

- are quality products which are produced in accordance to the recognized industrial regulations.
- left the manufacturer`s work in a perfect safety condition.



In order to maintain this condition, as installer / user you must carry out your task in accordance with the description in these instructions, technically correctly and with the greatest possible precision .



We assume, as a trained specialist you are having mechanical and electrical knowledge!



Satisfy yourself that the pressure reducers will only be used within their admissible limiting value (see the technical data) .

The pressure reducers must be used only for a purpose corresponding to their construction!

The pressure reducers must be used within the values specified in the technical data!



The operating of the pressure reducers outside the nominal temperature range could destroy the sealings and the bearings.

The operating of the pressure reducers outside the nominal pressure range could destroy the inner parts and the body.



Never remove a cap or a other component part if the pressure reducers will be under pressure.



Do not mount, start or adjust the pressure reducers if itself, the pipes or a mounted actuator will be damaged.



After the maintenance or repair check the right function of the pressure reducers and the tightness of the pipe connections.

Name-plate

4 Name-plate

The pressure reducers will be provided with a name-plate, which permits a definite identification of the pressure reducers and shows the most important technical data to you. The name-plate should not be displaced or changed.



Fig. 4.1 -name-plate

Art.Nr.	Article number of the pressure reducer
Serial	Order- or production number
Inlet pressure	max. admissible inlet pressure of the pressure reducer [bar]
Outlet pressure	outlet pressure range of the pressure reducer [bar]
Temperature (TS)	temperature range of the pressure reducer [°C]
G/DN	connecting size of the valve
Testing pressure (PT)	testing pressure of the pressure reducer
Fluidgroup	allowed fluid group of the pressure reducer
Date of manufacturing	Week and year of the manufacturing

5 Pressure reducer

5.1 General

Before mounting /disassembly the pressure reducer we assume that you have read the advices and warnings from chapter 3.



→ safety advice

If you have not read chapter 3. until now, read these important advices now and turn back to this page.

5.2 Corresponding use

Pressure reducers will be used to reduce the medium pressure (inlet pressure) upstream of the pressure reducer to a reduced pressure (outlet pressure) downstream of pressure reducer . It should only be used clean liquids and gases without doubts concerning the material resistance of the pressure reducer. Pollution or using outside the nomial pressure range and/or the nominal temperature range should causes damages on the pressurer reducer especially on the diaphragm.

5.3 Operation

The adjustment of a pressure reducer should happen without media flow (no media consumption), the manometer shows the static pressure.



Increase of the outlet pressure:

Turn the adjustment screw clockwise, until you will have reached the pressure as disired.

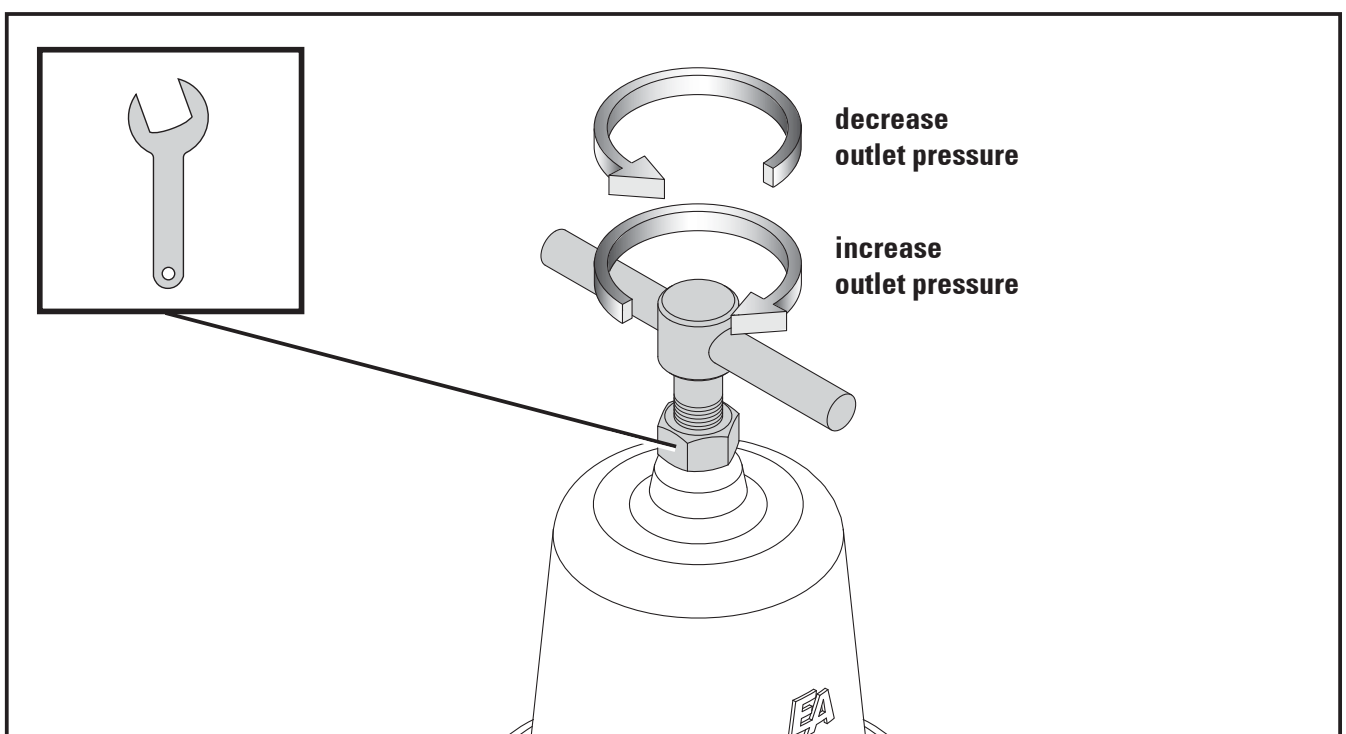

Fig. 5.1 - pressure reducer, adjustment of the outlet pressure (Fig. shows Art. DM330323).

Pressure reducer

Decrease of the outlet pressure:



Turn the adjustment screw anticlockwise. Consume some media to release the outlet pressure. Correct the the adjustment until you will have reached the pressure as disired.



With the counter nut you can prevent the unintentional distort of the adjustment screw.

A decreasing pressure during medium consumption is a normal reaction.

5.4 Mounting / Disassembly



The mechanical installation are the same by all variants. It differs by the type of connection only.



Consider the flow direction of the medium, specified on the valve body. Pressure reducers should be install with released spring.



The position of installation will be as you desired,an installation in vertical pipes with standing up bonnet is preferred.



We recommend the installation of gate valves in front of and behind the pressure reducer to clean the pressure reducer without emty of the conduit.



Remove the hole packing material (e.g. caps and plugs). Take care that there will be no packing material or other pollution in the pressure reducer.



Before mounting the pressure reducer clean up the pipes.



Avoid strains on the body by non align pipes.



Screw a mamometer into the manometer port. Not used ports must be closed by fit plugs.

Special Advice,- installation in boiler systems



Pressure reducer have to be installed in the upstream (cold water) of the system to avoid calcification. The distance to the check valve has to be far enough that the pressure reducer can not be reached by hot water even if the check valve is defective.

Please refer to DIN 1988 and AD leaflet A3 DIN 4753.



5.4.1 Mounting with threaded connection









Before lay on sealing compounds,check the hardly screwing by the pipes into the pressure reducer's body.



Lay on the correct sealing compounds on the pipes end. By using PTFE-ribbon or hemp sealings consider the screw direction. Don't use sealing compounds which are not prescribed for your employment.

-  Screw the pipes into the threaded ends of the pressure reducer. Don't use the bonnet of the spring as a lever.
-  Strike up the pipes with pressure after that time the manufacturer of the sealing compounds pretends for harden it.
-  Check the tightness of all connections.

5.4.2 Mounting with screw pipe connection

-  Before lay on sealing compounds,check the hardly screwing by the pipes into the pressure reducer's body.
-  Lay on the correct sealing compounds on the pipes end. By using PTFE-ribbon or hemp sealings observe the screw direction. Don't use sealing compounds which are not prescribed for your employment.
-  Put the screw caps onto the pipes and screw the screw pipe connections into the pipes.
-  Put the pressure reducer with the sealings between the screw pipe connections and tighten the screw caps.
-  Adjust the pressure reducer to the pipes. Tighten the screw caps.
-  Strike up the pipes with pressure after that time the manufacturer of the sealing compounds pretends for harden it.
-  Check the tightness of all connections.

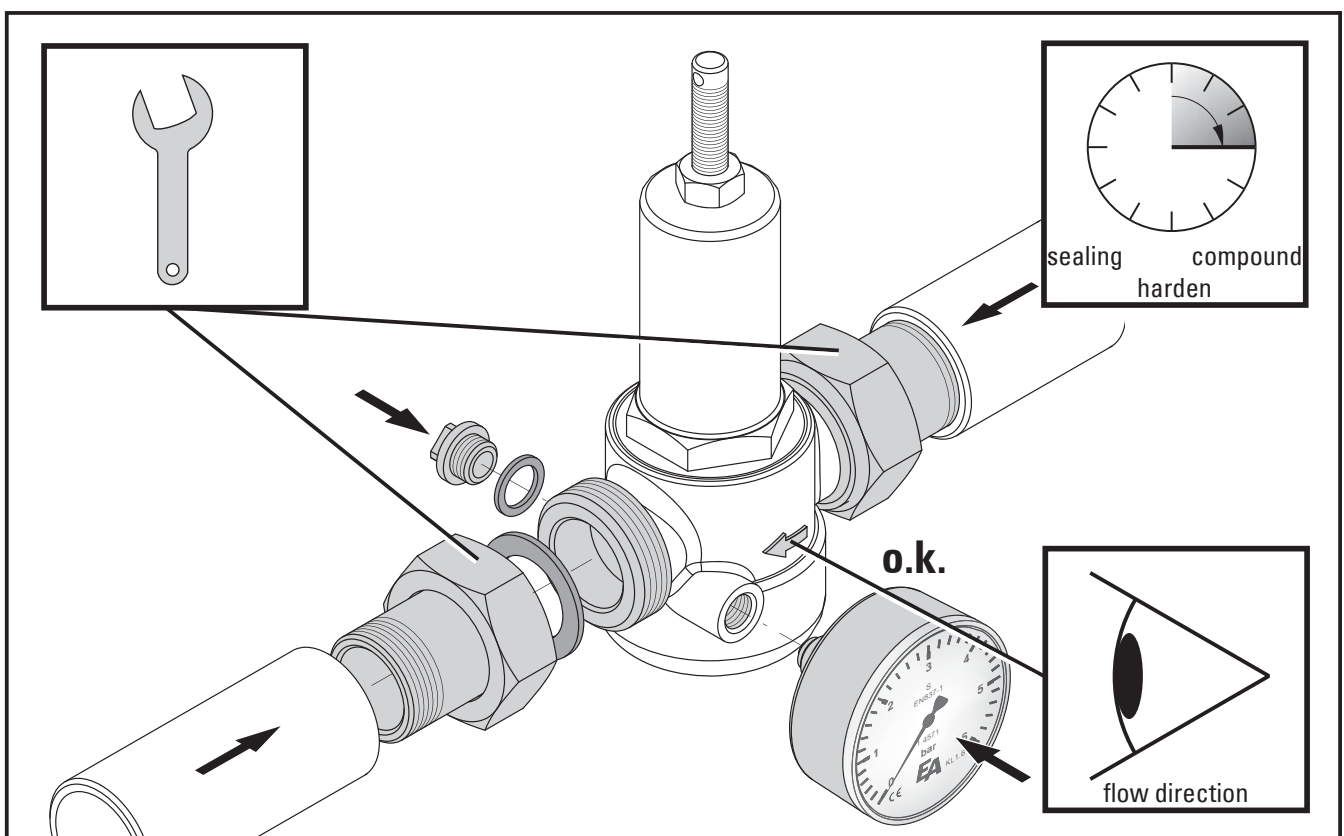

Fig. 5.2 - pressure reducer, mounting with screw pipe connection (Fig. Art. SD220025). Option: manometer Art.MO73xx

Pressure reducer

5.4.3 Mounting with welded connection



By welding the pressure reducer between the pipes you have to disassemble the pressure reducer first, to prevent the damage of the sealings.

5.4.3.1 Disassembly of the pressure reducer



The disassembling and mounting of the pressure reducer should happen with great care in a clean environment. Pollution will reduce the safety and the duration of life of the pressure reducer.



If you will disassemble some pressure reducers, place marks on the parts that you will be able to join the correct parts by a subsequent mounting of the pressure reducers.



Clamp the pressure reducer between a vice carefully. By using guard plates you can prevent the damage of the end of the pressure reducer's body.



Before disassembling the pressure reducer you have to release the spring to prevent the fly around of the pieces. Heavy injuries of persons or damages of the pieces would be the result.



Turn the adjustment screw anti clockwise, until the spring will be totally released.

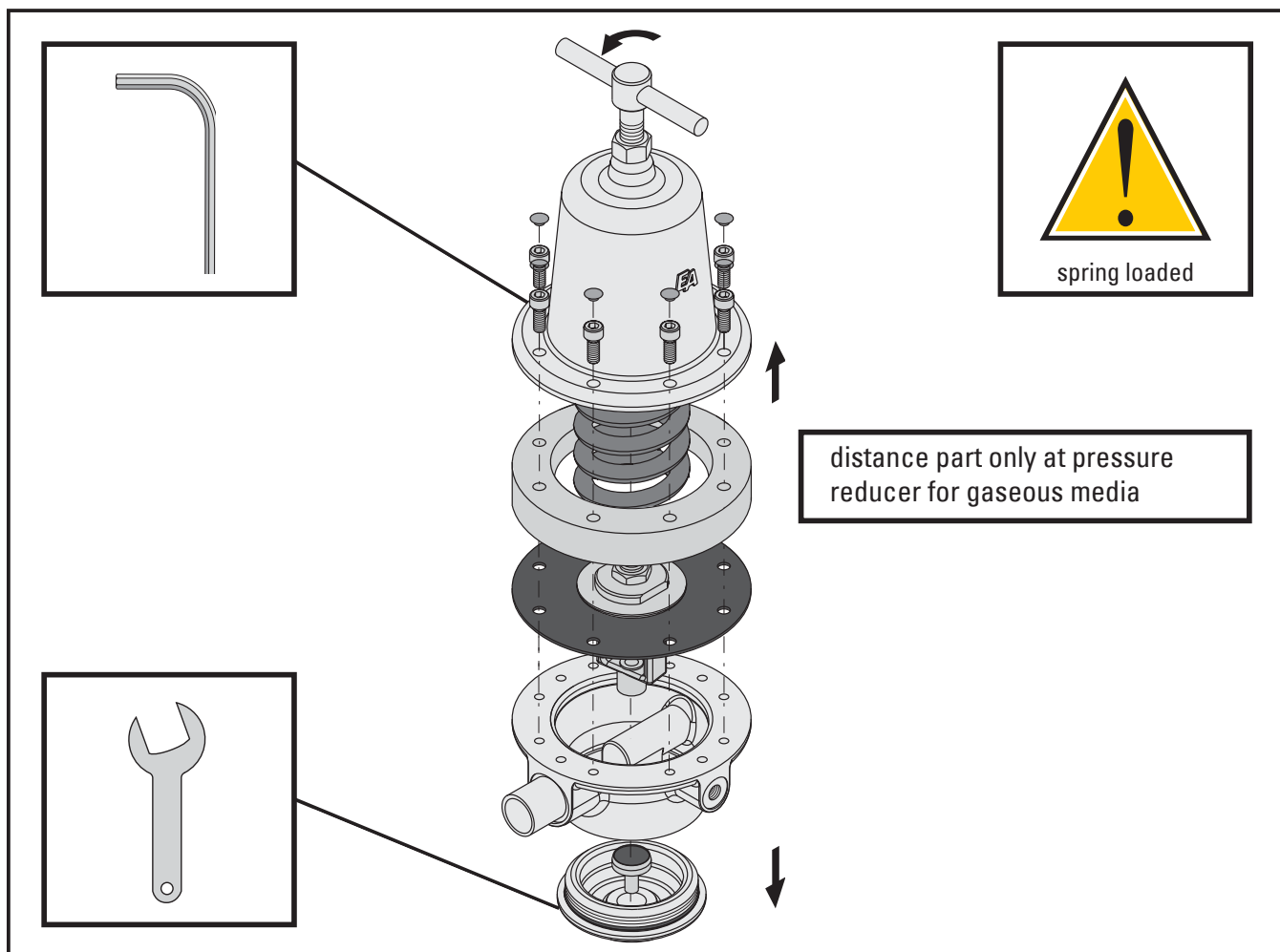







Fig. 5.3 - pressure reducer, mounting with welded connection, disassembling of a pressure reducer (Fig.: Art. DM330362).

-  Pull off the caps from the screws and loosen them crosswise. Pull the screws out of the body of the pressure reducer.
-  Take off the bonnet of pressure reducer and take it by side carefully.
-  Take off all the inner parts of the pressure reducer and take them by side carefully.
-  Turn the body around and screw out the cap with a fit spanner.

5.4.3.2 Welding of the body between two pipes

-  By welding the body of the pressure reducer with the pipes observe appropriate demands and guide lines.



The safety demands by welding are depending on the place and the position of the point of weld. Welding the parts at a serviceable device/machine/plant the potential of danger is as higher as welding the parts in a welding room.



If appropriate, inform the shift foreman / safety engineer or the works manager and the fire brigade of your factory

By welding observe your own national guide lines about safety and prevention of accidents.

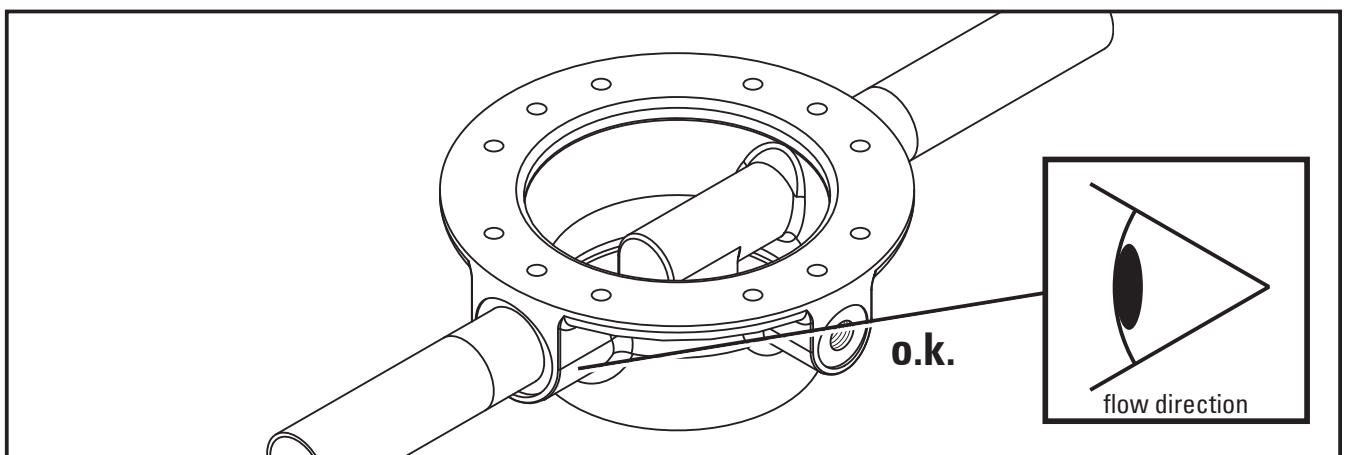

Fig. 5.4 - pressure reducer, welding of the body between two pipes (Fig. shows the body of Art. DM330362).

5.4.3.3 Mounting of the pressure reducer



Before mounting the pressure reducer let the body cool down.



The mounting of the pressure reducer takes place just the other way round to the disassembly of the pressure reducer.



Take care about the correct placement of the sealing and that there will be no pollution on the sealing or the seat.

Pressure reducer

 After mounting check the function of the pressure reducer.

 Check the tightness of all the connections.

5.4.4 Mounting with flanged connection



We assume, that you have mounted the flanges at the end of pipes and they are cooled down. (e.g. welded flanges).

 Push the body of the pressure reducer between the flanges by using the appropriate sealings.

 Aligns the flange borings and put the fit screws through the holes.

 Screw the fit nuts onto the screws and tighten it up crosswise. By doing this consider the maximum torque moment of the screws.

 Check the tightness of all connections.

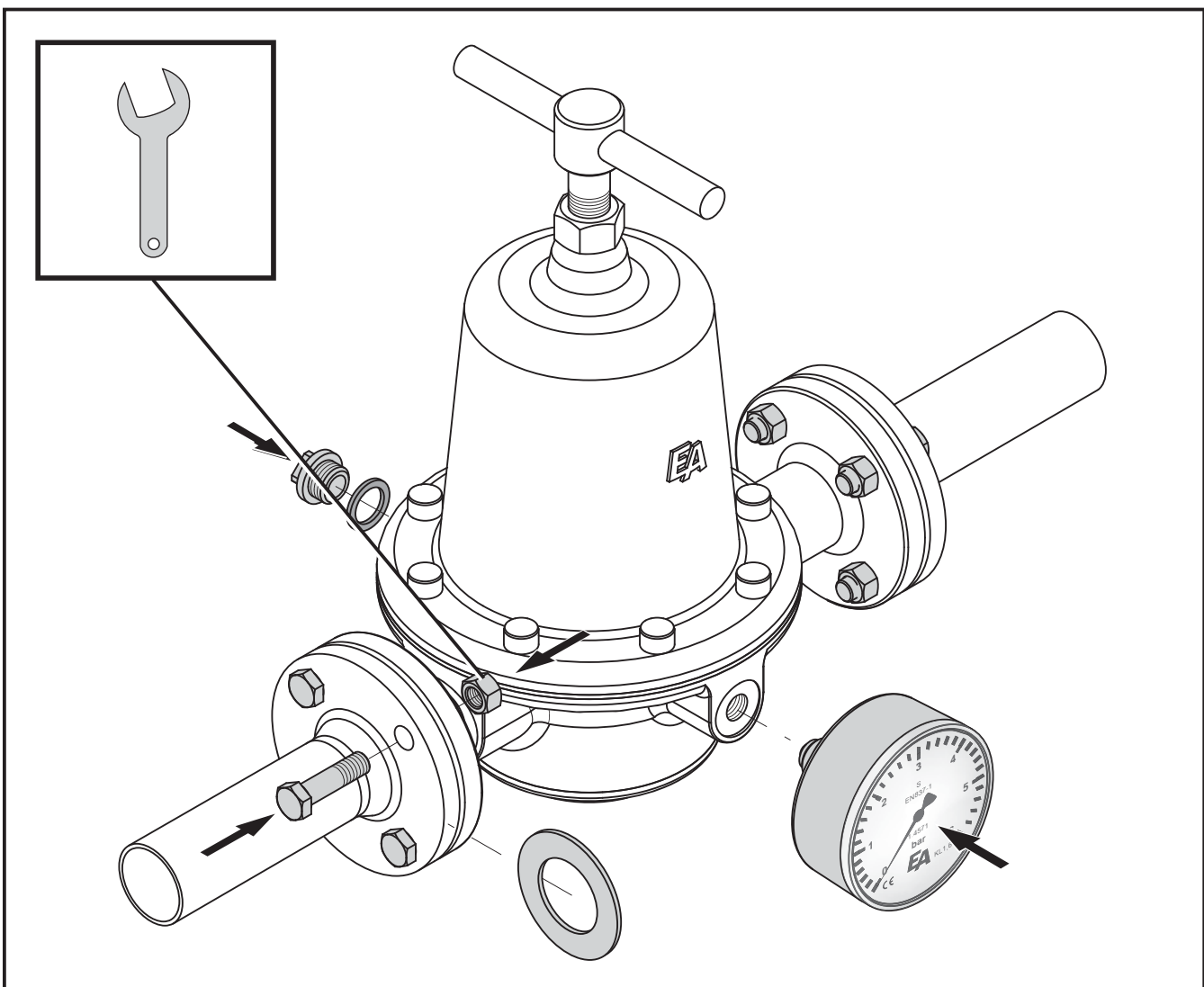

Fig. 5.5 - pressure reducer, mouting with flanged connection (Fig.: Art. DM330302). Option: manometer Art.M073xx

5.5 Maintenance

Before you maintain or shut down the pressure reducer you have to read



→ **Safety advice**

If you have not read the safety advices until now, read these important advices now and turn back to this page.

On normal accounts the pressure reducer is maintenance free. In periodical turns you have to:

- Check the function of the pressure reducer
- Check or clean the mesh (only Art. MB and SD)
- Check the right outlet pressure
- Check the tightness off all the connection

In case of a defect of the pressure reducer make a contact to the supplier. The telephone number will be found on the back or these operation and installation manual.



If you determinate that there is a damage to the pressure reducer switch off the device/ machine/ plant! However before doing this, it is essential to refer to the

→ **Safety advice.**

5.5.1 Cleaning of the mesh (only Art. MB and SD)



Cut off the medium flow on both sides of the pressure reducer and release the pressure in the pressure reducer.



Keep ready some fit tanks to catch up leaking liquids.



Before disassembling the pressure reducer you have to release the spring to prevent the fly around of the pieces . Heavy injuries of persons or damages of the pieces would be the result.



Turn the adjustment screw anti clockwise until the spring is totally released.



Loosen the bonnet with a fit spanner (Art. SD) or a pair of tongs (Art. MB).



Take off the bonnet of pressure reducer and take it by side carefully.



Take off all the inner parts of the pressure reducer and take them by side carefully.



Now the mesh could be taken out of the body of the pressure reducer.

Pressure reducer

By mounting please consider,



- that the cam or peg will be placed exactly above the counter part at the body,
- that the inner parts will not be braced by the placement into the body
- the correct placement of the sealings,
- that there will be no pollution on the sealings.



After mounting check the function of the pressure reducer.



Check the tightness of all connections.

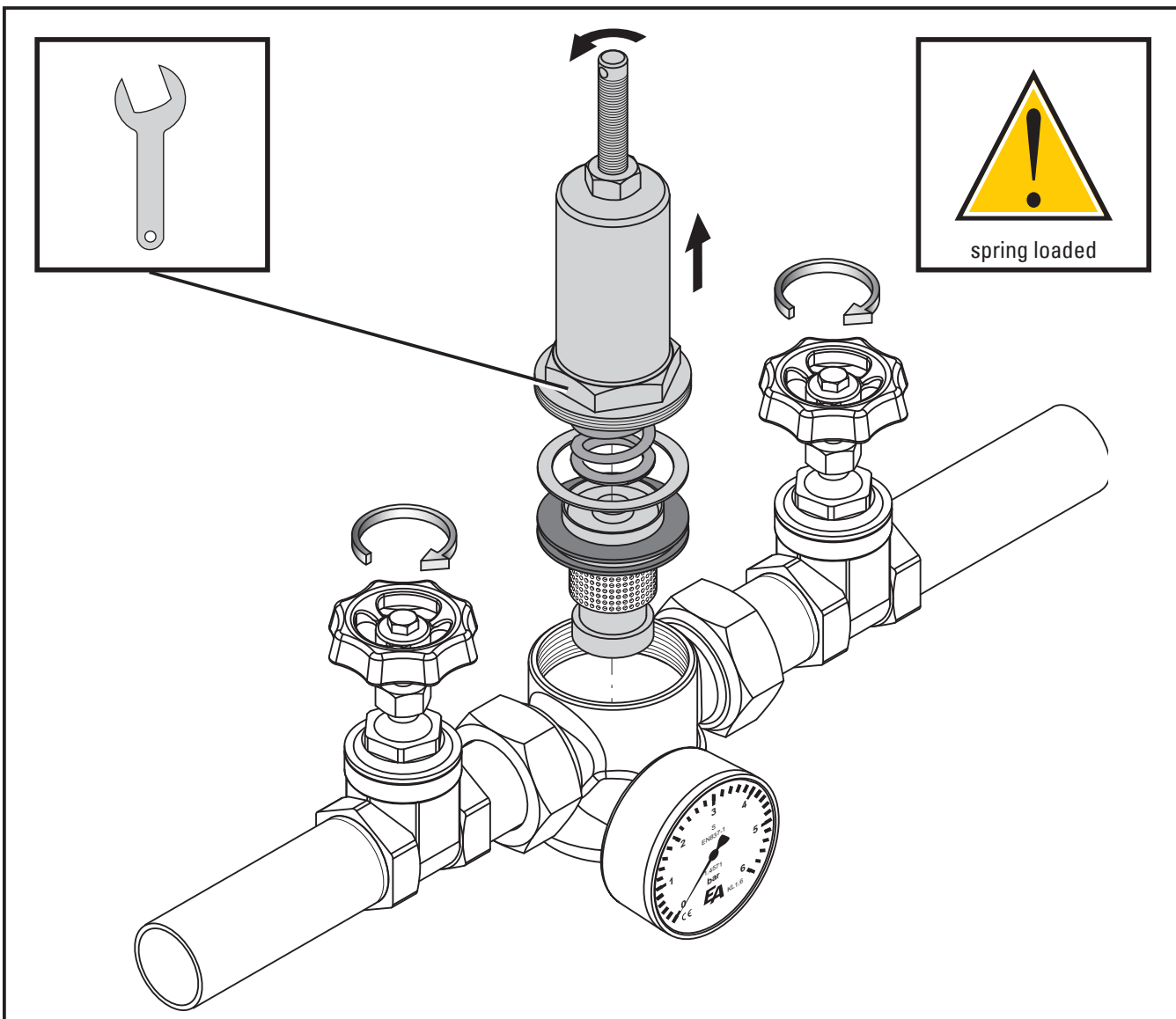

Fig.. 5.6 -pressure reducer, cleaning of the mesh(Art. SD220025). Option: manometer Art.M073xx



Qualität von Anfang an.

(1) **Declaration by the manufacturer**
(2) **as defined by Pressure-Equipment-Directive 97/23/EG**

(3) Herewith we declare that the supplied articles with nominal diameter \leq DN25:

CEA, DF2D5, DG2D1, DG2D2, DG3D2, DG3D3, DM, DW, KA, MBMG2Z, MBTG2S, MBTG2Z, MCAG2S, MEAG2D, MEAG3D, MEAG3S, MEMF2S, MEMG2S, MG, MGAG2D, MGAG3D, MGBG3D, MGMF2S, MGMF2Z, MGMG2S, MGMG2Z, MGTF2S, MGTF2Z, MGUG3D, MHK, NBA, NBK, ND, PS, SM, SW, SONV and all variations of these articles

(4) of the company **END-Automation GmbH & Co. KG**
D-32547 Bad Oeynhausen
Germany

(5) are in conformity with the regulations of Article 3 Part 3 of the directive 97/23/EG.

(6) These products bear no CE mark, but are in line to the good engineering practice designed and manufactured.

(7) Applied harmonized standards, in particular:

DIN EN 12516:2005 Industriearmaturen - Gehäusefestigkeit

(8) On behalf **END-Automation GmbH & Co. KG** Bad Oeynhausen, 01. März 2008



Friedhelm König
Technical Manager

END-Automation GmbH & Co. KG
Oberbecksener Str. 78
32547 Bad Oeynhausen · Germany
Telefon: +49 (0)5731 - 7901-0
Telefax: +49 (0)5731 - 7901-999
<http://www.end.de> · post@end.de



Michael End
Quality Manager



Qualität von Anfang an.

(1) **Declaration of conformity**
(2) **as defined by Pressure-Equipment-Directive 97/23/EG**

(3) Herewith we declare that the supplied articles:

AA, AB, AC, AD, AG, AR, BE, BF, BG, BH, BK, CA, CB, CD, CK, CU, CV, CW, DM, EA, EA, EB, EK, FG, IC, IG, IK, IL, KA, KU, MA, MB, MD, MR, NG, PB, PD, RG, RK, RM, SD, SV, TA, TB, TC, TD, TE, TF, TH, TR, UV, VA, VC, VD, VH, VK, VL, VM, VN, VO, VT, VU, WG, ZA, ZE, ZF, ZG, ZK, ZP, SONV, and all variants.

(4) of the company **END-Armaturen GmbH & Co. KG**
D-32547 Bad Oeynhausen
Germany

(5) are in conformity with the regulations of the directive 97/23/EG.

(6) Applied conformity assessment: Modul H.

(7) Notified body for conformity assessment PED an Quality-Management-System:



Bureau Veritas S.A.
Paris / Frankreich
Kennzeichen 0062

(8) Applied harmonized standards, in particular:

DIN 3840:1982 **Armaturengehäuse**
Festigkeitsberechnung gegen Innendruck

(9) On behalf

Friedhelm König
Technical Manager

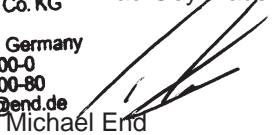

END-Armaturen GmbH & Co. KG
Oberbecksener Str. 78
32547 Bad Oeynhausen · Germany
Telefon: +49 (0)5731 - 7900-0
Telefax: +49 (0)5731 - 7900-80
<http://www.end.de> post@end.de

Bad Oeynhausen, 28. Mai 2002

Michael End
Quality Manager



END-Armaturen GmbH & Co. KG



Qualität von Anfang an.

Qualität von Anfang an.

END-Armaturen GmbH & Co. KG

Oberbecksener Str.78
 D-32547 Bad Oeynhausen
 Postfach (PLZ 32503) 100 341
 Telefon +49 (0) 5731 / 7900-0
 Telefax +49 (0) 5731 / 7900-199
 Internet <http://www.end.de>
 E-Mail post@end.de

END-Automation GmbH & Co. KG

Oberbecksener Str.78
 D-32547 Bad Oeynhausen
 Postfach (PLZ 32503) 100 342
 Telefon +49 (0) 5731 / 7901-0
 Telefax +49 (0) 5731 / 7901-999
 Internet <http://www.end.de>
 E-Mail post@end.de

Watergates GmbH & Co. KG

Oberbecksener Str.70
 D-32547 Bad Oeynhausen
 Postfach (PLZ 32503) 100 321
 Telefon +49 (0) 5731 / 7900-0
 Telefax +49 (0) 5731 / 7900-199
 Internet <http://www.watergates.de>
 E-Mail post@watergates.de



№ 171010101E