



Qualität von Anfang an.

Original Operating Manual Pressure Actuated Valve

DG2D1
DG2D2
DG2D3, DA2D3, DL2D3, DM2D3,
DG3D3, DF3D



acc. to annex VI of the Directive 2006/42/EC



© **END-Automation GmbH & Co. KG**

All rights reserved. No part of this publication may be copied or published by means of printing, photocopying, microfilm or otherwise without prior written consent of **END-Automation GmbH & Co.KG**. This restriction also applies to the corresponding drawings. **END-Automation GmbH & Co. KG** has the right to change parts of the valves at any time without prior or direct notice to the client. The contents of this publication are subject to change without notice.

This publication has been written with great care. However, **END-Automation GmbH & Co. KG** cannot be held responsible, either for any errors occurring in this publication or for their consequences.

The products are specified by the statements in this documentation; no assurance of the properties is given.

END-Automation GmbH & Co. KG
Oberbecksener Straße 78
D-32547 Bad Oeynhausen
Telefon: 05731 / 7901 - 0
Telefax: 05731 / 7901 - 999
Internet: <http://www.end.de>
E-Mail: post@end.de

Edition: 12/09

Chapter	Title	Side
1	Foreword.....	5
2	General advice.....	6
2.1	Validity	6
2.2	Inward monitoring	6
2.3	Complaints	6
2.4	Guarantee	6
2.5	Symbols and their signification	7
3	Safety advice.....	7
3.1	Personal protection.....	7
3.1.1	Safety advice for mounting	7
3.1.2	Safety advice for adjustment / starting.....	8
3.2	Device safety.....	9
4	Device descriptions.....	10
4.1	Device description Pressure Actuated Valve	10
4.2	Types of Pilot cylinder.....	11
4.3	Device variants	12
4.4	Name- plate	13
4.5	Description of function	13
4.5.1	General.....	13
4.5.2	Normally close with flow direction.....	14
4.5.3	Normally close against flow direction	15
4.5.4	Normally open against flow direction	15
4.5.5	Double acting	15
4.5.6	Description of function: Pressure actuated valve (3/2-way).....	16
4.5.6.1	Split function.....	16
4.5.6.2	Mixing function	16
4.6	Description of the options function	17
4.6.1	Pilot valve.....	17
4.6.2	Position indicator.....	17
4.6.2.1	Optical position indicator	17
4.6.2.2	Electrical position indicator	17
4.6.3	Manual override.....	17
4.6.4	Stroke stop.....	17
5	Assembly Instructions.....	18
5.1	Mounting of the valve (threaded connection)	19
5.2	Mounting of the valve (welded connection)	20
5.2.1	Disassembly of the valve top	20
5.2.2	Welding of the body between two pipes	21
5.2.3	Mounting of the valve top	22
5.3	Mounting of the valve (flanged valve).....	23
5.4	Connection of the pilot medium.....	24
5.5	Mounting of pilot valve (Option).....	25
5.5.1	Pneumatical installation of the pilot valve.....	26
5.5.2	Electrical installation of the pilot valve	26
5.6	Electrical installation of a position indicator (Option)	27

5.7	Disassembly.....	28
5.7.1	Electrical disassembly (Option).....	28
5.7.2	Mechanical disassembly.....	28
6.	Adjustment /Starting.....	29
6.1	Stroke stop (Option).....	29
6.2	Starting.....	30
7	Emergency operation with manual override (Option).....	30
8	Failure.....	31
8.1	Failure causes.....	31
9	Maintenance / Cleaning.....	32
9.1	Maintenance.....	32
9.2	Cleaning.....	32
10	Technical data.....	33
10.1	Technical data DG2D1xx.....	33
10.2	Technical data DG2D2xx.....	34
10.3	Technical data DG2D3xx, DA2D3xx, DL2D3xx, DM2D3xx.....	35
10.4	Technical data DG3D3xx.....	36
10.5	Technical data DF3Dxx.....	37

1 Foreword

Dear customer,
Dear assembler / user,

these operating instructions are intended to give you the knowledge which is necessary for you to be able to carry out the mounting and adjustment of an pressure actuated valve DG2D rapidly and correctly.



Please read these instructions carefully and pay particular attention to the advice and warning notes.

Only instructed and qualified mechanic should mount, adjust or maintain the pressure acting valves.

The pressure acting valves will be deliver in several versions relative to

- pilot pressure and pressure range
- operations
- material
- connection type and connection size.

There are also several options available.

With accessories

- it can switch the pilot media
- it can indicate the position of the piston
- it can happen a manual override
- it can stop the stroke

The field of use of this valve is predominantly

- in food and drink industry
- in chemical installations
- in ventilation and blower construction
- in heating and air-conditioning technology
- in industrial fittings
- in water treatment etc.

If you have any questions in relation to the pressure acting valves DG2D, we shall be pleased to answer them.

The telephone number will be found on the inside cover of these operation and installation manual.

Yours

END-Automation GmbH & Co. KG

2 General advice

2.1 Validity

This mounting and installation manual is valid for the standard version of the pressure actuated valves DG2D1xx, DG2D2xx, DG2D3xx, DA2D3xx, DL2D3xx, DM2D3xx, DG3D3xx and DF3D. On the following pages the valves will be named DG2D.

2.2 Inward monitoring

Please check

- directly after delivery the valve for any transport damages and deficiencies
- with reference to the accompanying delivery note the number of parts.

Do not leave any parts in the package.

2.3 Complaints

Claims for replacement of goods which relate to transport damage can only be considered valid if the delivery company is notified without delay.

In case of returns (because of transport damage/repairs), please make a damage protocol and send the parts back to the manufacturer, if possible in the original packaging.

In case of return, please mention the following:

- Name and address of the consignee
- Stock-/ordering-/article-number
- Description of the defect

2.4 Guarantee

For our pressure actuated valve we give a guarantee period in accordance with the sales contract.

The warranty and guarantee rules of **END-Automation GmbH & Co. KG** are applicable.

2.5 Symbols and their Signification



Paragraphs which are identified with this symbol contain very important advices; this also includes advices for averting health risks.
Observe these paragraphs without fail!



Paragraphs which are identified with this symbol contain very important advices; this also includes how to avoid damage to property.
Observe these paragraphs without fail!



This symbol indicates paragraphs which contain comments/advice or tips.



This bullet identifies the description of actions which you should carry out.

3. Safety advice

Depending on the technical circumstances and the time under and at which the valve is mounted, adjusted and commissioned, you must in each case take into account particular safety aspects!

If, for example, the valve works in an operational chemical plant, the potential hazards of commissioning have another dimension from that when this is only being carried out for test purposes in a „dry“ part of the plant in the assembly room.

Since we do not know the circumstances at the time of the mounting/adjustment/commissioning, you may find advice on hazards in the following descriptions which are not relevant to you .

Please observe (only) the advice which applies to your situation!



The partly completed machinery must not be put into service until the final machinery into which it is to be incorporated has been declared in conformity with the provisions of the Directive 2006/42/EC on machinery, where appropriate.

3.1. Personal protection

3.1.1. Safety advice for mounting



We wish to point out expressly that the mounting, the electrical installation and the adjustment of the valves and the accessories must be carried out only by trained specialist personnel having mechanical and electrical knowledge!



**Switch off all the devices / machines / plant affected by mounting or repair.
If appropriate, isolate the devices / machines / plant from the mains.**



Check (for example in chemical plants) whether the switching off of devices / machines / plant will cause potential danger.



If appropriate, in the event of a fault in the valve (in a plant which is in operation) inform the shift foreman / safety engineer or the works manager without delay about the fault, in order, for example, to avoid an outflow / overflow of chemicals or the discharge of gases in good time by means of suitable measures!



Before mounting or repair, relief the pressure from pneumatic / hydraulic devices / machines / plant.



Empty the conduit from medium.



If necessary, set up warning signs in order to prevent the inadvertent starting up of the devices / machines / plant.



Observe the respective relevant professional safety and accident prevention regulations when carrying out the mounting / repair work.



Check the correct functioning of the safety equipment (for example the emergency push off buttons/ safety valves, etc)!

3.1.2 Safety advice for adjustment and starting

As a result of the starting (pneumatic or by hand) of a pressure actuated valve the flow of gases, steam, liquids, etc. may be enabled or interrupted!



Satisfy yourself that, as the result of the starting or the test adjustments of the valve, no potential hazards will be produced for the personnel or the environment!



If necessary, set up warning signs in order to prevent the inadvertent starting up or shutting down of the devices / machines / plant.

By ending mounting check the correct function and the tightness of the valve.



Check the right position and correct function of mounted pilot valves and limit switches



Through suitable measures, prevent actuating links being trapped by moving actuating elements!



Check the right function of all safety devices (for example emergency off push buttons / safety valves, etc.)!



Carry out the starting and the adjustments only in accordance with the instructions discribed in this documentation!



When adjustments are being carried out on an opened and switch on (operational) limit switches or pilot valves, there is the risk that live parts(230V AC~) can be touched!

Therefore the adjustment must be carried out only by the electrician or a person having adequate training, who is aware of the potential hazard.

3.2 Device safety

The pressure actuated valves

- is a quality product which is produced in accordance with the recognized industrial regulations.
- left the manufacturer`s work in a perfect safety condition!



In order to maintain this condition, as installer / user you must carry out your task in accordance with the descriptions in these instructions, technically correctly and with the greatest possible precision!

We assume, as trained specialist you are having mechanical and electrical knowledge !



The valves must be used only for a purpose corresponding to its construction!

The valves must be used within the values specified in the technical data.

The mentioned data are experience values only and describe the general condition of our product. They should be used as a guideline to evaluate the suitability of the non-concrete individual case, but without any guarantee for the suitability given by END-Automation.

The final responsibility to proof and confirm the suitability of our products, for which we confirm the perfect (faultless) quality by our delivery- and payment terms, lies in the dependance with your constructive responsibility to the end-user.



Satisfy yourself that, as the result of the mounting, the starting or as a result of the test adjustments on the valves, no potential hazards will be produced for devices / machines / plant!

Open the valve only to such an extent as described in this documentation!



Do not loose the locking ring of the pilot cylinder or don`t try to disassemble the pilot cylinder.



Do not mount the valve, start the valve or carry out any adjustments on it if the valve, the supply lines or the part of the plant on which it is flange- mounted is damaged !



By ending mounting check the correct function and the tightness of the valve and check the correct function of the pilot valve and limit switches.

4 Device descriptions

4.1 Device description pressure actuated valve

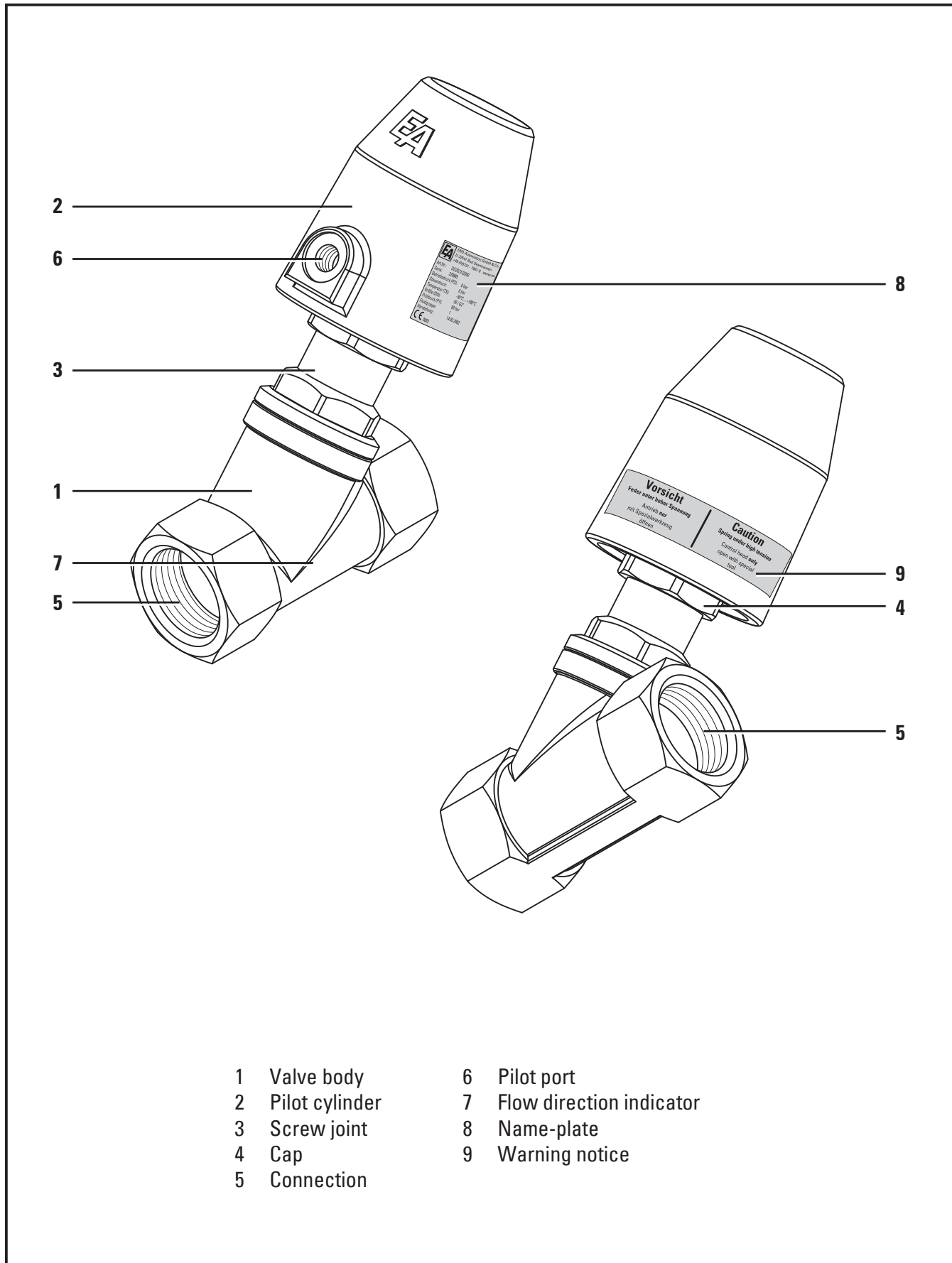

Fig. 4.1 -Device description, front / rear (figure shows DG2D3111025 without options)

4.2 Types of pilot cylinder, NC

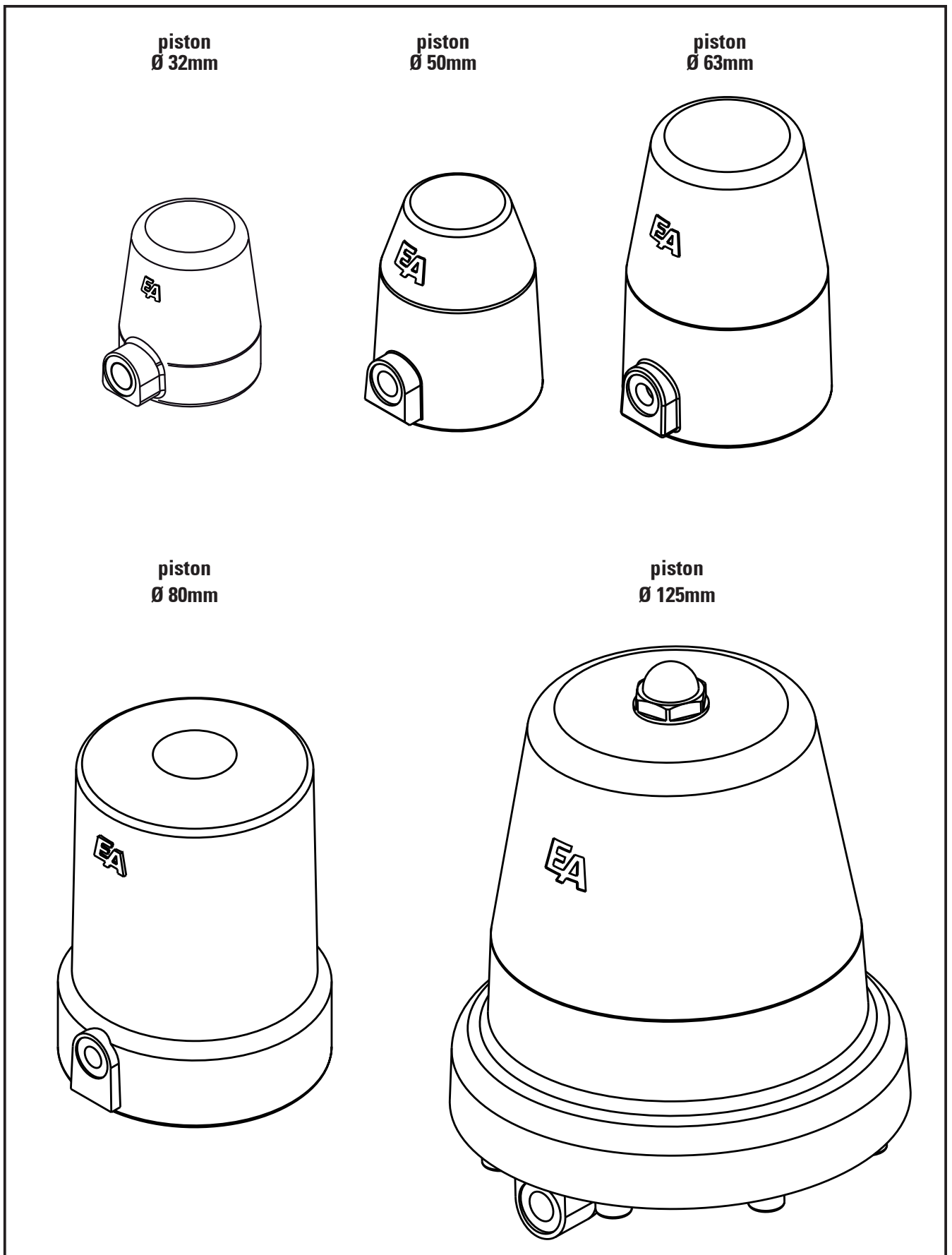

Fig. 4.2 -Types of pilot cylinder, NC (witout options)

4.3 Device variants

The pressure actuated valves DG2D will be delivered in various variants.

The following table explains the composition of the article number to you. These article numbers will be seen on the name plate:

For example: **DG2D3116025/OS**
 Pressure actuated valve, Stainless steel / PTFE, normally close with the flow direction, Stainless steel cylinder, G 1", with optical position indicator

1. Digit Product	2. Digit Connection	3. Digit Ways	4. Digit Operation	5. Digit Body material
D = Pressure actuated valve	G = B.S.P. thread DIN ISO 228 T1 A = Welded connection DIN 3293 L = Welded connection ISO 4200 M = Welded connection DIN 11850-R2 F = flanges acc. to DIN 2531 / 2533 / 2545	2 = 2/2-ways 3 = 3/2-ways	D = direct acting	1 = brass 2 = bronze 3 = stainless steel 4 = Carbon steel 5 = GG (grey cast iron) 6 = GGG (ductile iron) 7 = Light alloy 8 = Plastic
6. Digit Seals material seat / stem	7. Digit Operation	8. Digit Piston- Ø	9. - 11. Digit Connection	
1 = PTFE / PTFE 2 = PTFE / NBR 3 = PTFE / FKM 4 = PTFE / EPDM 5 = NBR / PTFE 6 = NBR / NBR 7 = FKM / FKM 8 = FKM / PTFE	for 2/2-way-version: 1 = Normally close with the flow direction 2 = Normally close against the flow direction 3 = Normally open against flow direction 4 = Double acting for 3/2-way-version: 1 = split function 2 = mixing function	brass cylinder 0 = Ø 32 mm 1 = Ø 50 mm 2 = Ø 80 mm 3 = Ø 125 mm (aluminium alloy) 4 = Ø 100 mm stainless steel cylinder 5 = Ø 50 mm 6 = Ø 80 mm 7 = Ø 125 mm (aluminium alloy) 8 = Ø 100 mm 9 = Ø 32 mm	006 = G 1/8 008 = G 1/4 010 = G 3/8 015 = G 1/2 020 = G 3/4 025 = G 1 032 = G 1 1/4 040 = G 1 1/2 050 = G 2 065 = G 2 1/2 080 = G 3 100 = G 4 125 = others sizes 150 = on request	threaded connection flanged and welded connection DN 15 DN 20 DN 25 DN 32 DN 40 DN 50 DN 65 DN 80 DN 100 DN 125 DN 150
12. - 20. Digit Options				
ES = electric / mechanic position indicator FL = flanged connection PN 16 HB = stroke stop HN = manual override HY = hygienic version HO = stroke stop and optical position indicator	NI = inductive proximity limit switch OF = free of oil and grease OG = without valve body OS = optical position indicator NS = contactless position indicator (Reed- contact) V = for vacuum VD = for vacuum and pressure			

4.4 Name-plate

The pressure acting valves DG2D will be provided with a name-plate, which permits a definite identification of the valves and shows the most important technical data to you. The name-plate should not be displaced or changed.



Fig. 4.3 - Name-plate

Art.Nr.	Article number of the valve (see also chapter 4. „device variants“)
Serie	Order- or production-number
Betriebsdruck (PS)	Max. admissible working pressure of the valve [bar]
Steuerdruck	Recommend pilot pressure of the valve [bar]
Temperatur (TS)	Temperature range of the valve
Größe (DN)	Connecting size of the valve
Prüfdruck (PT)	Testing pressure of the valve
Fluidgruppe	Allowed fluid group of the valve
Herstellung	Date of manufacturing

A potential fixed CE- mark relates to the Pressure Equipment Directive 97/23/EG.

4.5 Description of function

4.5.1 General

A slanting seat in the valve body will be closed with or against the flow direction by a valve disk. The valve disk is connected with the piston by a stem. It's dynamical sealing and guidance happens by a screw joint between valve body and pilot cylinder. The slanting valve design renders a highly flow rate by low dirtyness.

Pressure actuated valves would be actuated with the a piston by a neutral pilot media (air, water, oil). It works in a pressure range from 0 bar up to the max. nominal pressure which you can see in the pressure table. The flow direction is fixed and signed on the valve.

Description of function



The electrical control signal will be changed into the pressure media control by an optional available solenoid valve. The figure 4.4 shows a directly mounted solenoid valve type MGAG3D.

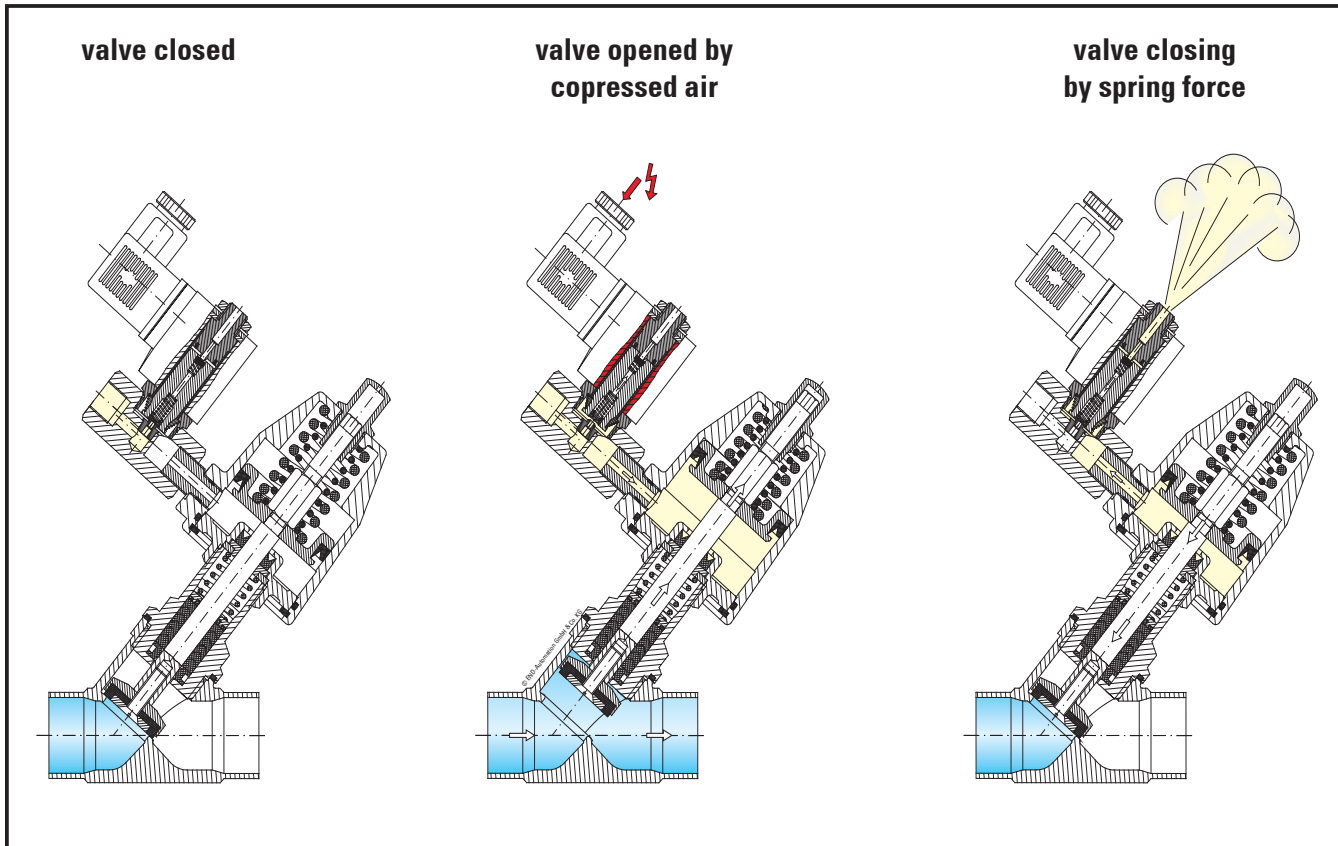

Fig. 4.4 - Description of function (Options: optical position indicator, solenoid valve)

4.5.2 Normally close with the flow direction

The in neutral position closed valve obtains this function by a spring, which acts in close direction. By feeding with compressed air the pilot pressure moves the piston against the spring and lift up the valve disk from the seat. Therefore the valves open.

Because the valve closes with the flow direction, the nominal pressure supports the closing process and seals the valve disk against the seat additionally. If the media flows through the valve with a high speed the valve could close too fast and this could cause pressure shocks in the pipes.

We recommend the use of this operation mode only at gaseous media. The using of liquid media could cause pressure shocks in the pipe.

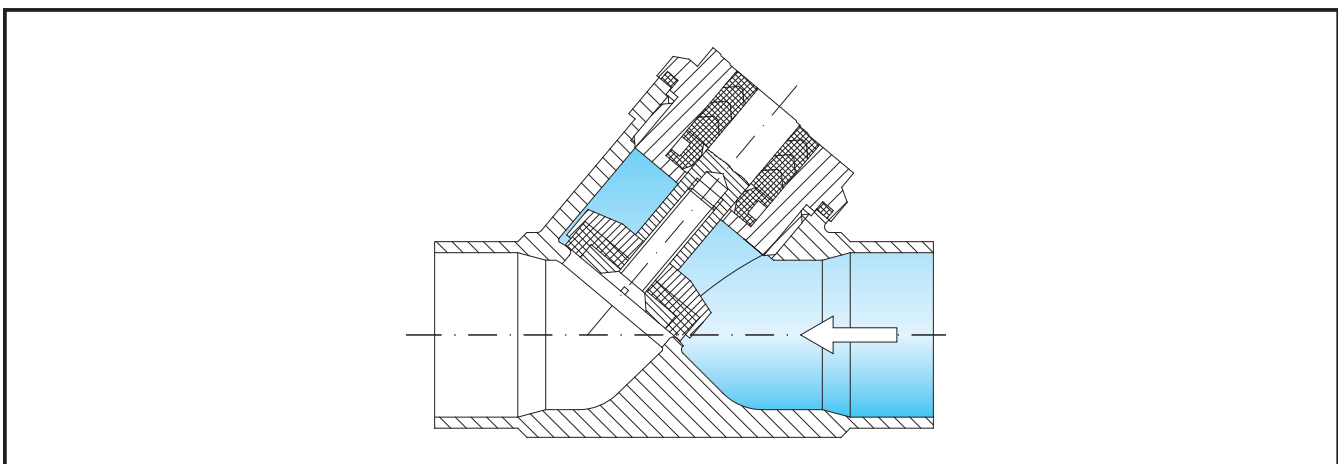

Fig. 4.5 - Description of function - Normally close with the flow direction

4.5.3 Normally close against the flow direction

The in neutral position closed valve obtains this function by a spring, which acts in close direction. By feeding with compressed air the pilot pressure moves the piston against the spring and lift up the valve disk from the seat. Therefore the valves open.

The valve closes against the flow direction only by the spring force. Therefore the valve closes slowly and prevents pressure shocks in the pipes.

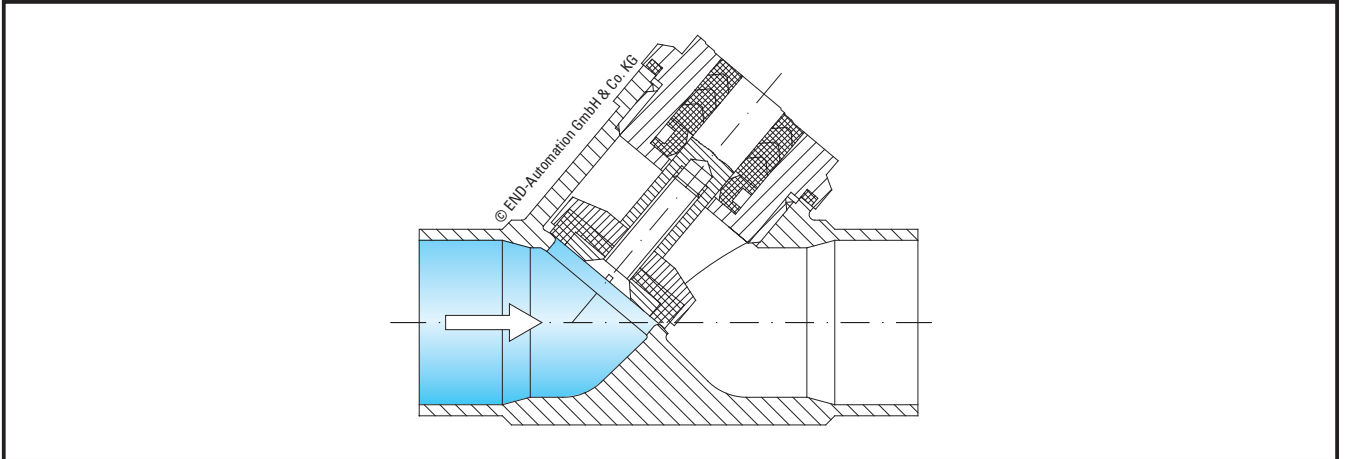

Fig. 4.6 - Description of function - Normally close against the flow direction

4.5.4 Normally open, close against the flow direction

The in neutral position opened valve obtains this function by springs mounted under the piston. The valve closes against the flow direction only by the pilot pressure.

4.5.5 Double acting

The valve closes against the flow direction only by the pilot pressure. The valve opens with the flow direction only by the pilot pressure.

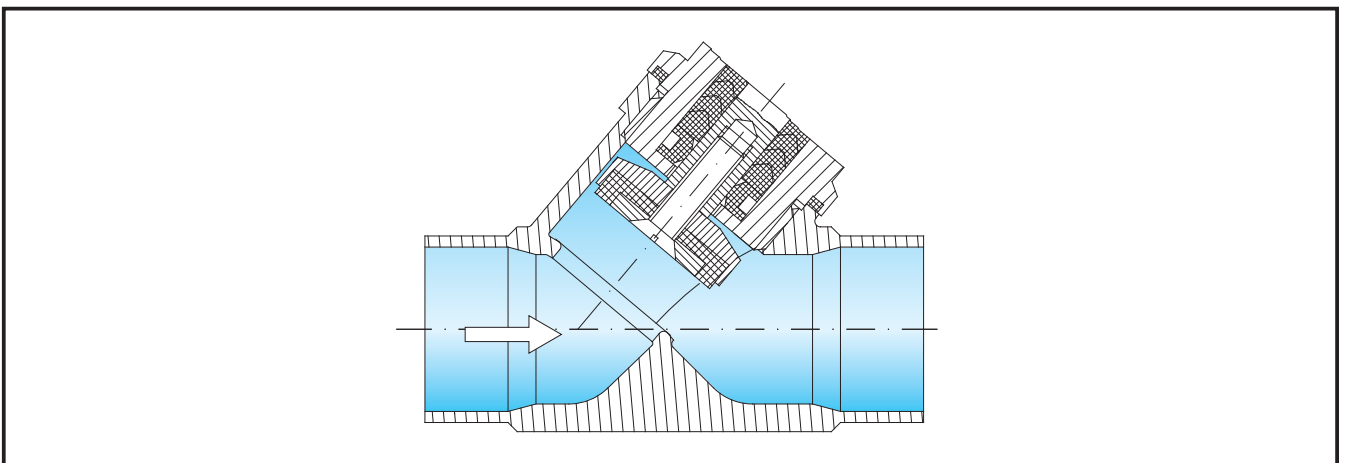

Fig. 4.7 - Description of function - Normally open, close against flow direction; Double acting

4.5.6 Description of function: Pressure actuated valve (3/2-way)

A straight seat in the valve body will be closed with or against the flow direction by a valve disk. The valve disk is connected with the piston by a stem. Its dynamical sealing and guidance happens by a screw joint between valve body and pilot cylinder. The 3/2-way pressure actuated valve renders two functions:

1. split function
2. mixing function

Pressure actuated valves would be actuated with a piston by a neutral pilot media (air, water, oil). It works in a pressure range from 0 bar up to the max. nominal pressure which you can see in the pressure table. The flow direction is fixed and signed on the valve.

4.5.6.1 Split function

At this function the valve will be pressurized by the inlet port P. In case of the position of the piston the medium flows from the inlet port to one of the outlet ports. ($P \blacktriangleright A / P \blacktriangleright B$)

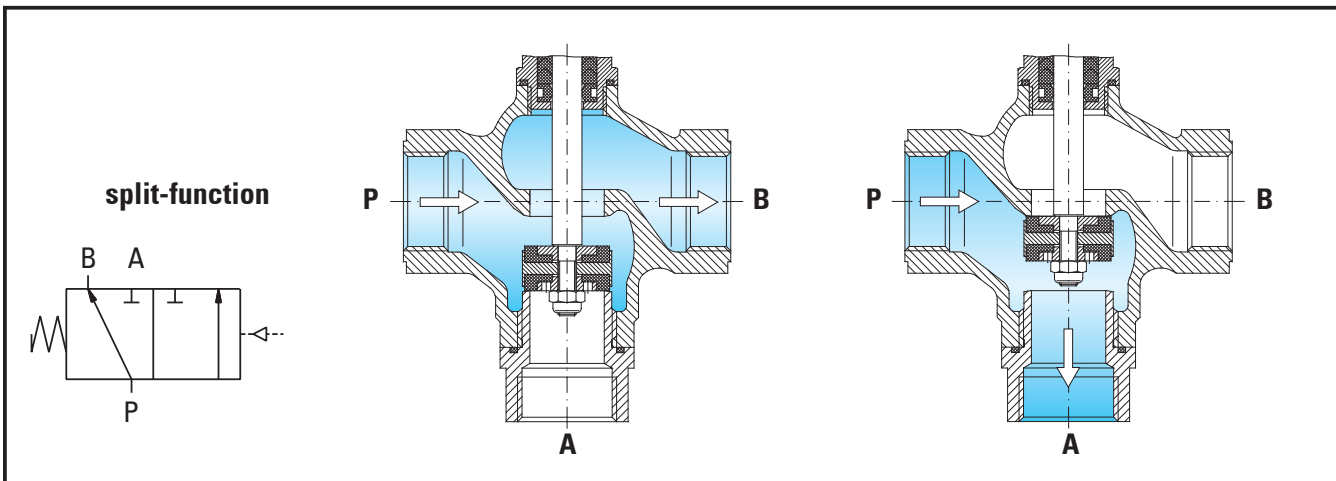

Fig. 4.8 - Description of function: split function

4.5.6.2 Mixing function

At this function the valve will be pressurized by two ports (P_1 / P_2). In case of the position of the piston the medium flows from one of the two inlet ports to the outlet port. ($P_1 \blacktriangleright A / P_2 \blacktriangleright A$)

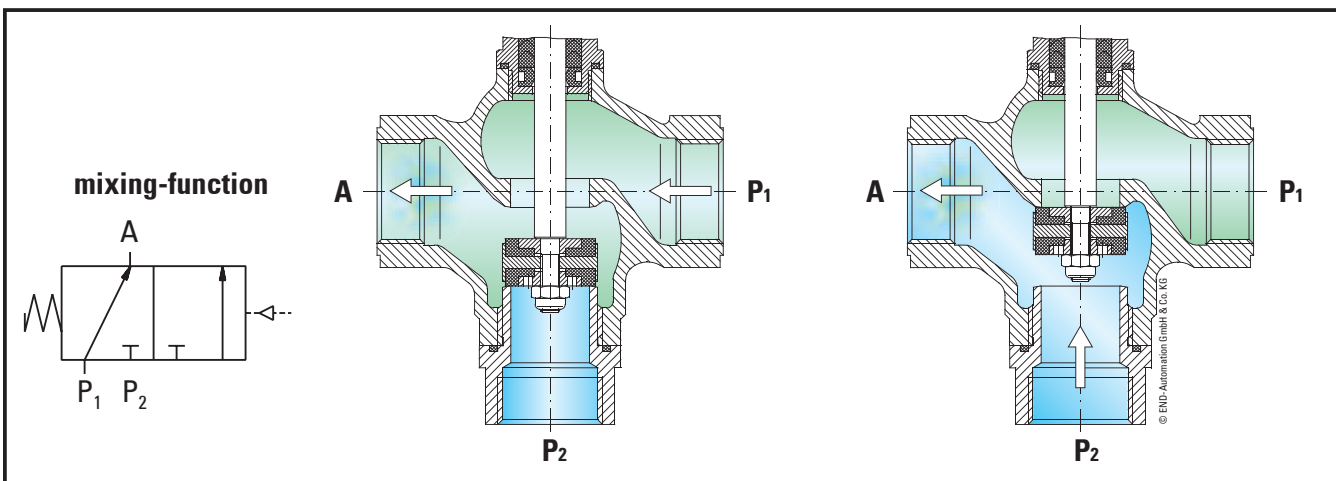

Fig. 4.9 - Description of function: mixing function

4.6 Description of options function

4.6.1 Pilot valve (Option)

The 3/2- ways pilot valve which is necessary to control the pressure actuated valve will be mounted directly on the pilot cylinder or in an external control box. For double acting valves it is necessary to install a 4/2- or 5/2-ways pilot valve. The valve position will be selected by feeding compressed air. The actuating time will be controlled by throttle valves.

4.6.2 Position indicator (Option)

The signal of the position of the pressure actuated valve can be indicate in different ways: by an optical position indicator or by an electrical position indicator.

4.6.2.1 Optical position indicator (Option)

On the stem there is a red pin mounted, which indicates the position of the valve on top of the pilot cylinder. The hole for the red pin in the pilot cylinder is covered by a clear plastic cap. You can see the pin in the position „open“.

4.6.2.2 Electrical position indicator (Option)

The electrical position indicator indicates the position of the valve over a long distance or sends a electrical signal to a control box. For this there are several position indicators available: electric-mechanic position indicator, contactless position indicator (Reed- contact) or inductive proximity limit switch.

By the different variants one or both valve positions can be indicated.

4.6.3 Manual override (Option)

By the option „Manual override“ the pressure actuated valve can be opened or closed by a hand wheel. By turning the hand wheel the stem of the valve lift up the valve disk from the seat or senk down the valve disk. See also chapter 9. „Emergency operation with manual override“.

4.6.4 Stroke stop (Option)

You are able to limited the stroke in the valve by a stroke stop. Therefore you can regulate the flow rate of the valve.

5. Assembly Instructions

The mounting of the pressure actuated valve restricts to

- the mechanical mounting into the prescribed pipes
- the connection of the hose for the pilot medium with the pilot port
- the electrical mounting of accessories, e.g.. pilot valve or limit switch.

The installation of the pressure actuated valve is as you desired.



In the following description we assume, that you have read the former chapters attentive. We also assume that you will observe the safety advices and warnings from chapter 3. „safety advice“ during the mounting / disassembly.

If you have not read chapter 3.„Safety advices“ until now, read these important advices now and turn back to this page!

The mounting and the electrical installation must be carried out only by trained specialest personnel having mechanical and electrical knowledge!



The following figures are showing the pressure actuated valves without any options! Perhaps the valve mounting by you is equiped with options!

Your device variant you can see at the name-plate on the pilot cylinder of the valve. For their meaning see also chapter

→ **4.3 „Device variants“.**

The mechanical installation are the same by all variants. It differs only by the type of connection.





Observe the flow direction, specified on the valve body.

Before mounting the valve clean up the pipes. Pollution will be reduce the safety and the lifetime of the valve. If necessary mount a Y- strainer in front of the valve.

Avoid strains of the valve body by non align pipes.

The electrical installation conforms to the installed options.

5.1 Mounting of the valve (threaded connection)

-  Before lay on sealing compounds, check the hardly screwing by the pipes into the valve body.
-  Lay on the correct sealing compounds on the pipes end. By using PTFE- ribbon or hemp seals observe the screw direction. Don't use sealing compounds which are not prescribed for your employment.
-  Screw the pipes into the connection ends of the valves. Don't use the pilot cylinder as a lever.
-  Strike up the pipes with pressure after that time the manufacturer of the sealing compounds pre-tends for harden it.
-  Check the tightness at all connections.

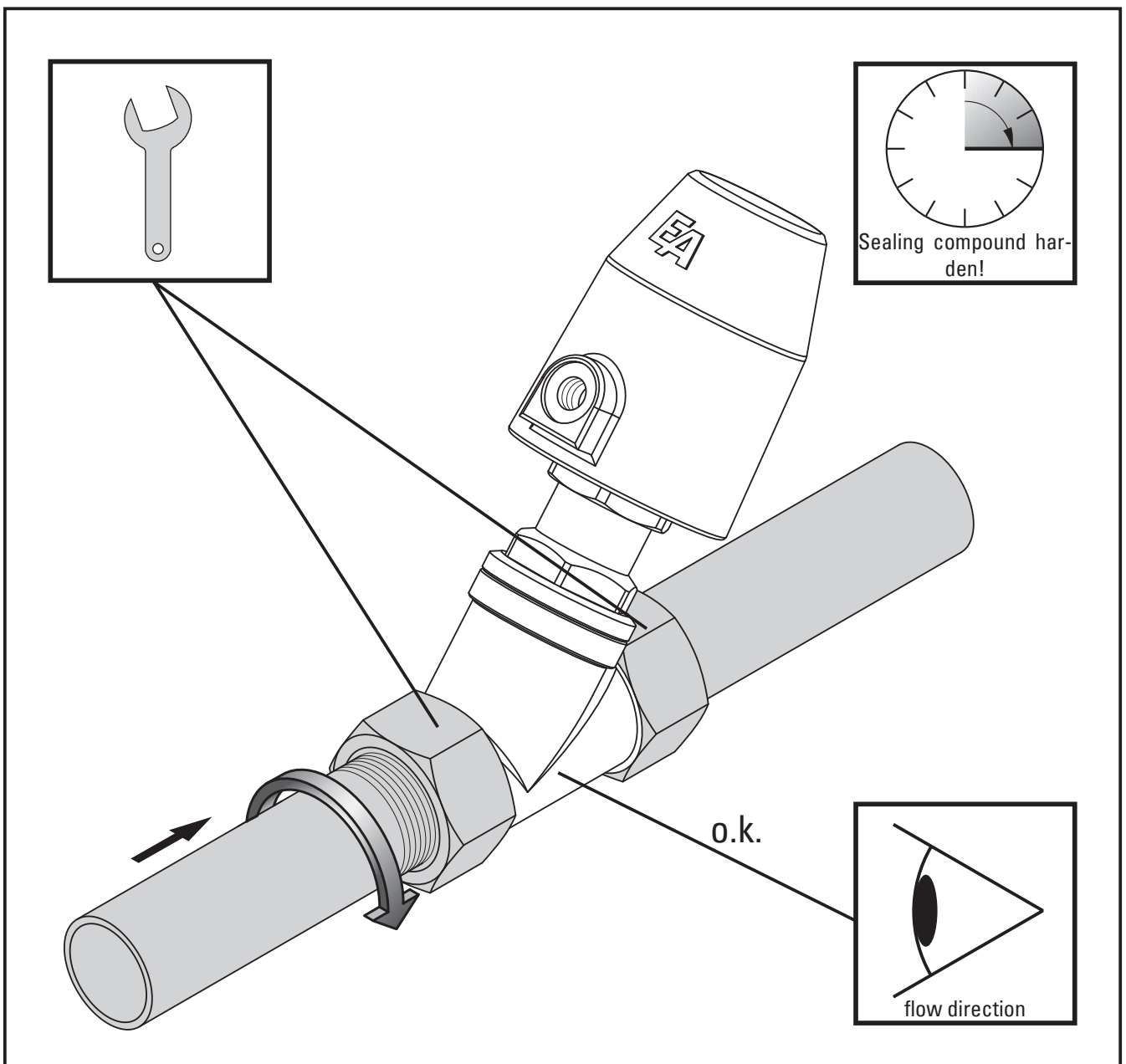

Fig. 5.1 - Mounting / disassembly - threaded connection

5.2 Mounting of the valve (welded connection)



By welding the valve between the pipes you have to disassemble the valve top first, to prevent the damage of the seals.

5.2.1 Disassembly of the valve top



Clamp the valve between a vice carefully. By using guard plates you can prevent the damage of the ends of the body.



At valves with the function „normally close“ we recommend to lift up the valve disk from the seat (see also chapter 4.2 „Device variants“). Therefore you have to screw a appropriate hose connector into the pilot port and to connect it with a compressed air hose. By feeding the hose with compressed air with a maximum pressure of 6 bar the valve disk will lift up from the seat.



Loosen the valve top with a fit spanner. The spanner have to put on to the hexagon nut of the screw joint. Never put the spanner on to the hexagon nut of the bonnet of the pilot cylinder.



Screw out the valve top of the valve body and take it by side carefully. Place a mark on the body and the pilot cylinder that you will be able to join the correct parts by a subsequent mounting of valve.

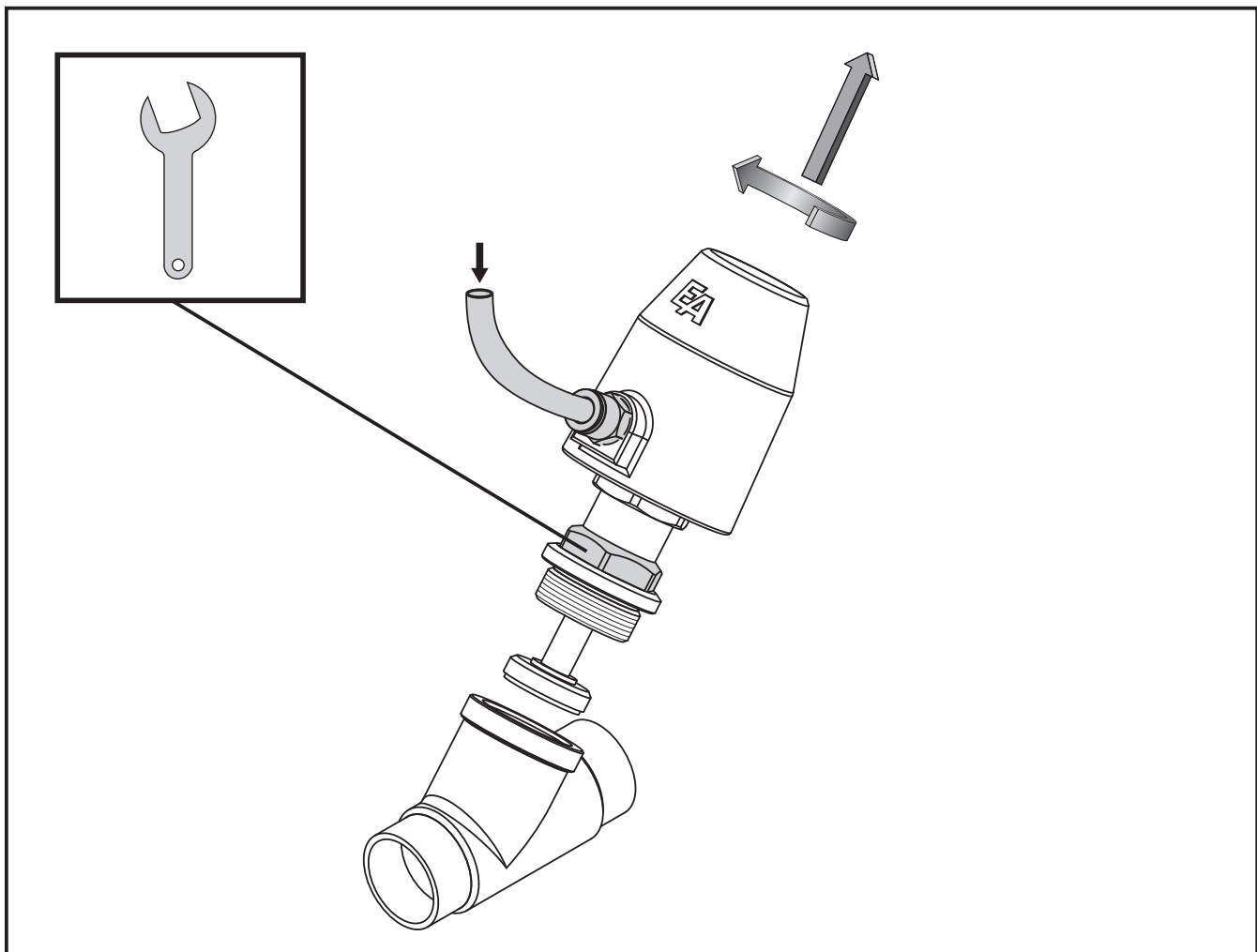

Fig. 5.2 -Mounting / disassembly - welded connection, disassembly of valve top

5.2.2 Welding of the body between two pipes



By welding the valve body with the pipes observe appropriate demands and guide lines.



The safety demands by welding are depending on the place and the position of the point of weld. Welding the parts at a serviceable device/machine/plant the potential of danger is as higher as welding the parts in a welding room.

If appropriate, inform the shift foreman / safety engineer or the works manager and the fire brigade of your factory

By welding observe your own national guide lines about safety and prevention of accidents.

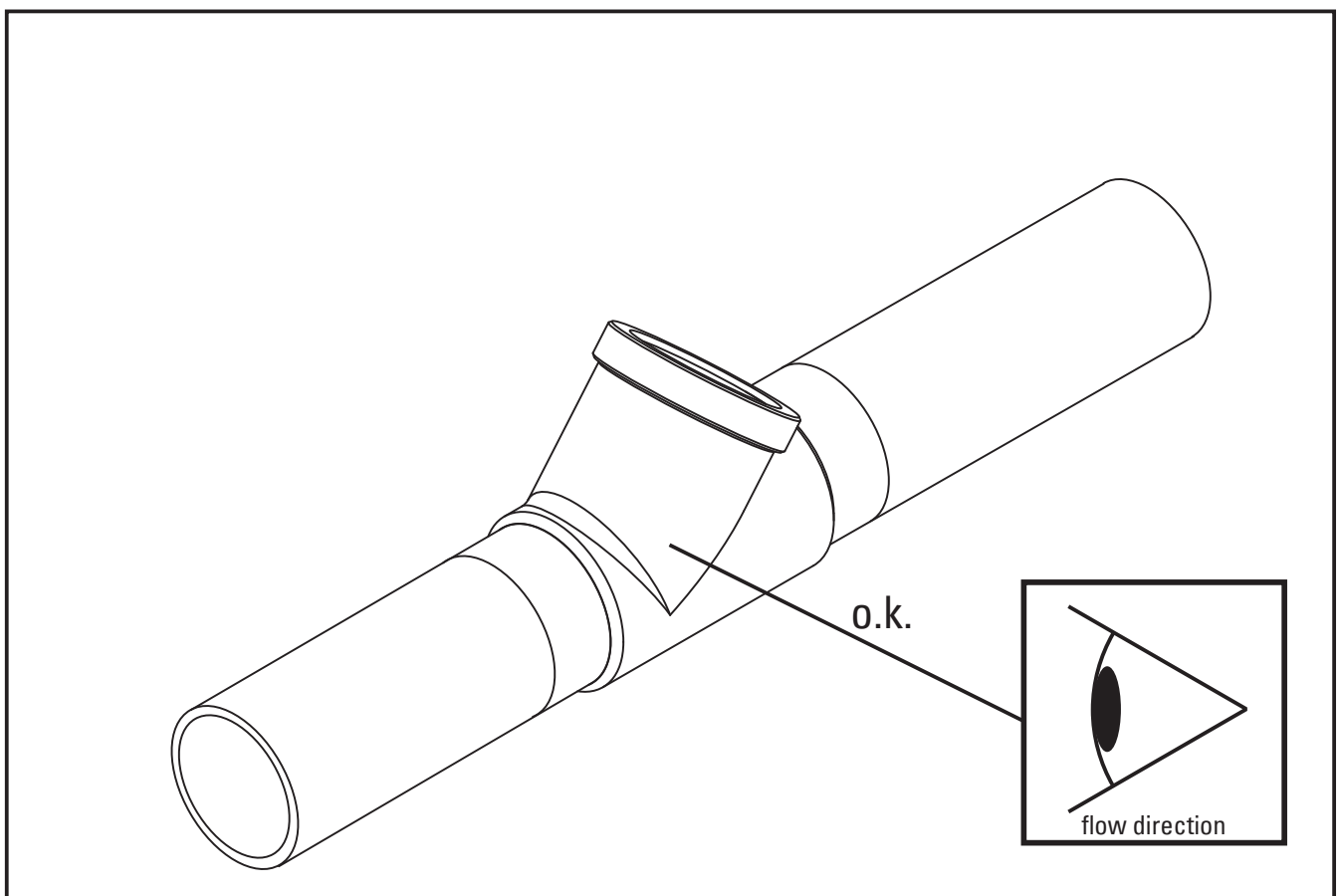

Fig. 5.3 - Mounting / disassembly - welded connection, welding of the body

5.2.3 Mounting of the valve top



Before mounting the valve top let the valve body cool down.



Screw the valve top into the body. If necessary attach the valve tops to the bodies.



Take care about the correct placement of the sealing into the screw joint and that there will be no pollution on the sealing or the seat.



Tighten the valve top with a fit spanner. The spanner have to put on to the hexagon nut of the screw joint. Never put the spanner on to the hexagon nut of the bonnet of the pilot cylinder.



Let off the compressed air to get the valve disk in its neutral position.



Check the tightness at all connections.

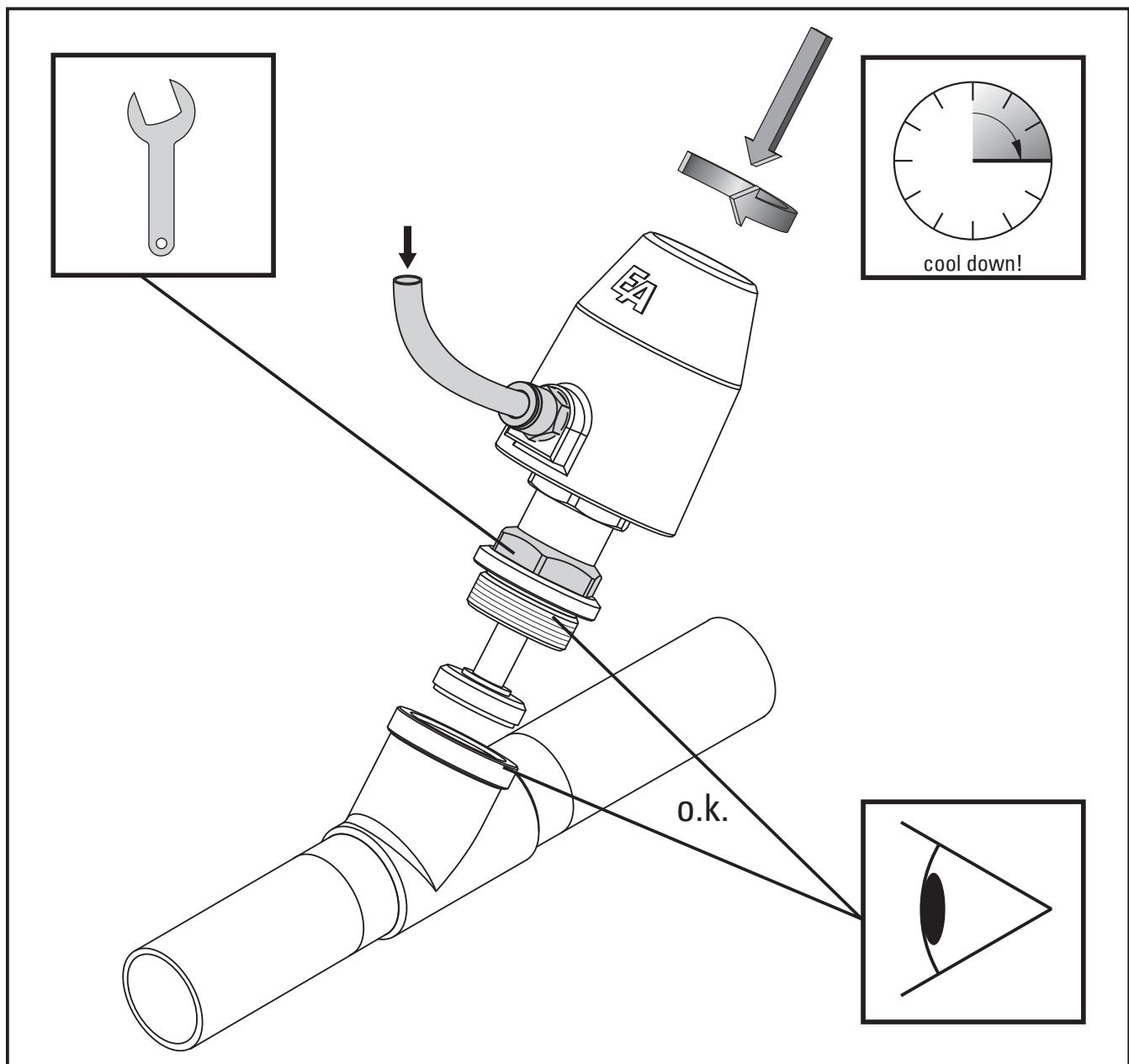

Fig. 5.4 - Mounting / disassembly - welded connections, mounting of the valve top

5.3 Mounting of the valve (flanged connection)



We assume, that you have mounted the flanges at the end of pipes and they are cooled down. (e.g. welded flanges).



Push the valve body between the flanges by using the appropriate sealings.



Aligns the flange drill holes and put the fit screws through the holes.



Screw the fit nuts onto the screws and tighten it up crosswise. By doing this observe the maximum torque moment of the screws.



Check the tightness at all connections.

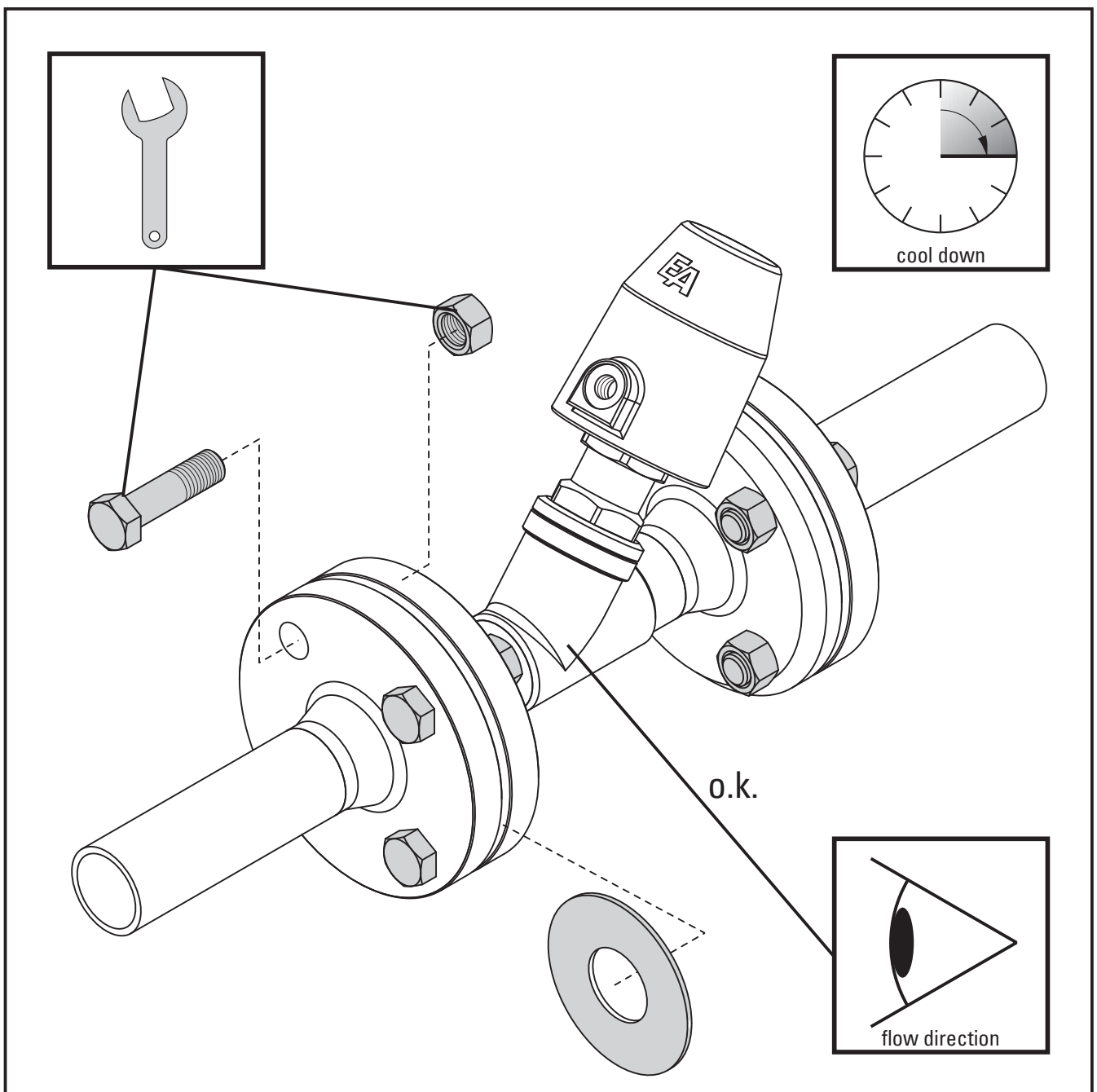

Fig. 5.5 - Mounting / disassembly - flange connection

5.4 Connection of the pilot medium

By choosing the pilot media observe the the specification in chapter

→ 10 „Technical data“.



You have to screw a appropriate hose connector into the pilot port.



By using liquid sealing compounds take care that no surplus sealing compound will flow into the pilot cylinder.



Feeds the pilot hose with pressure after the time will has gone by the manufacturer prescribes to harden the sealing compound.



Connect the pilot medium hose with the hose connector. Use only the correct hose for your appli-
cation.



Fasten the hose into the hose connector.



By laying the hose take care, that the hose will not be creased, squeezed or sheared or that the hose will be laid over edges. Also take care that there will be no pressure or traction on the hose.



Lay the hoses to their starting positions as appropriate, in conduits or cable ducts.



Check the tightness at all connections.

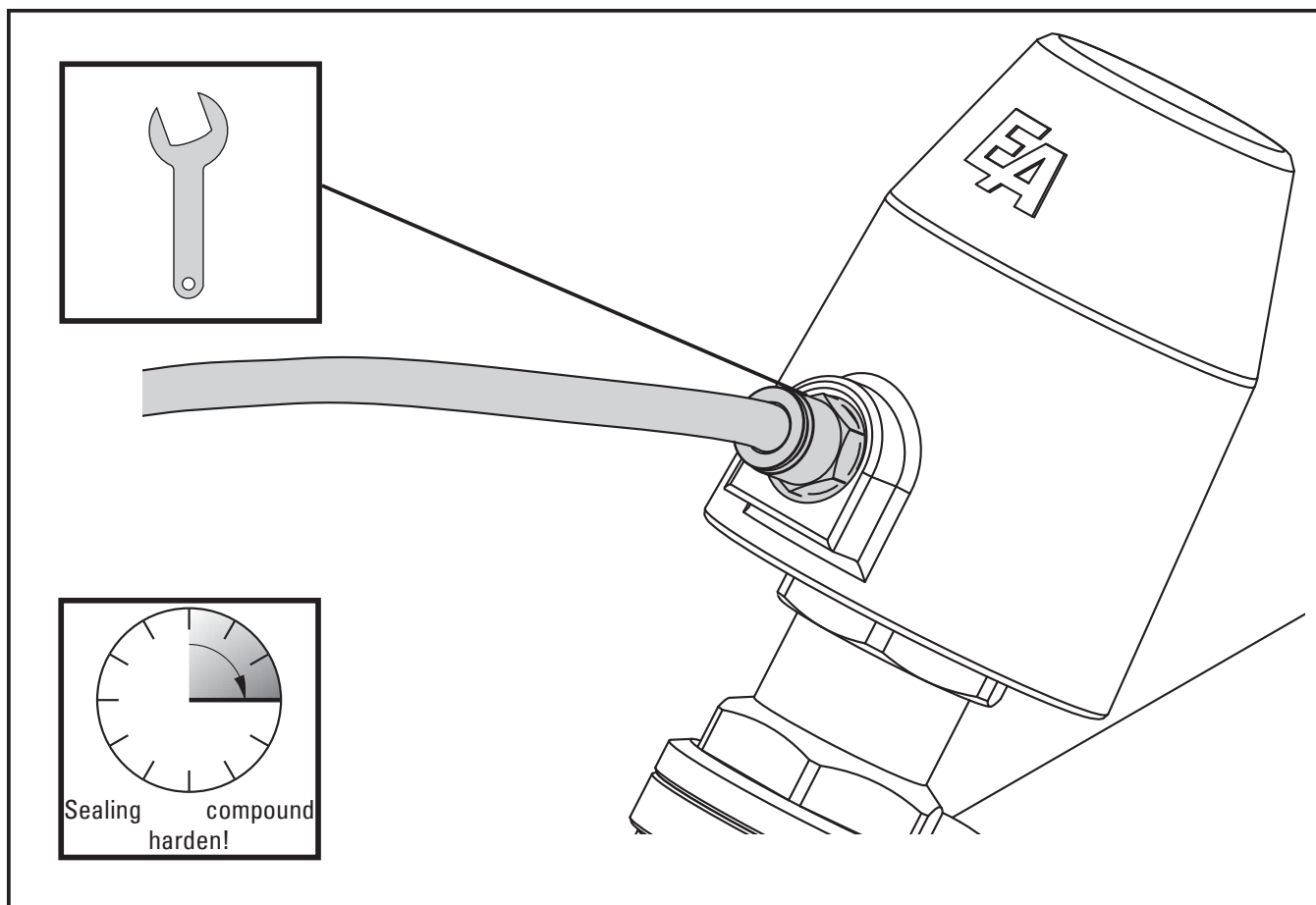

Fig. 5.6 - Mounting / disassembly - Connection of the pilot medium

5.5. Mounting of a pilot valve (Option)

5.5.1 Pneumatically installation of a pilot valve

If your pressure actuated is equipped with a pilot valve by the manufacturer, the fittings are sealed.



If the solenoid valve is an additional delivery, the solenoid valve must be screw in the pilot port of the pressure actuated valve.



A sealing is on the male thread, other sealing compounds are not necessary.



By tighten the solenoid valve use a suitable spanner. Don't use the solenoid valve as a lever.



The connection of the pilot media ensues by the devices of chapter

→ 5.4 „Mounting of the connector of the pilot medium“,



by screwing the threaded connection of the hose into the free thread connection of the pilot valve

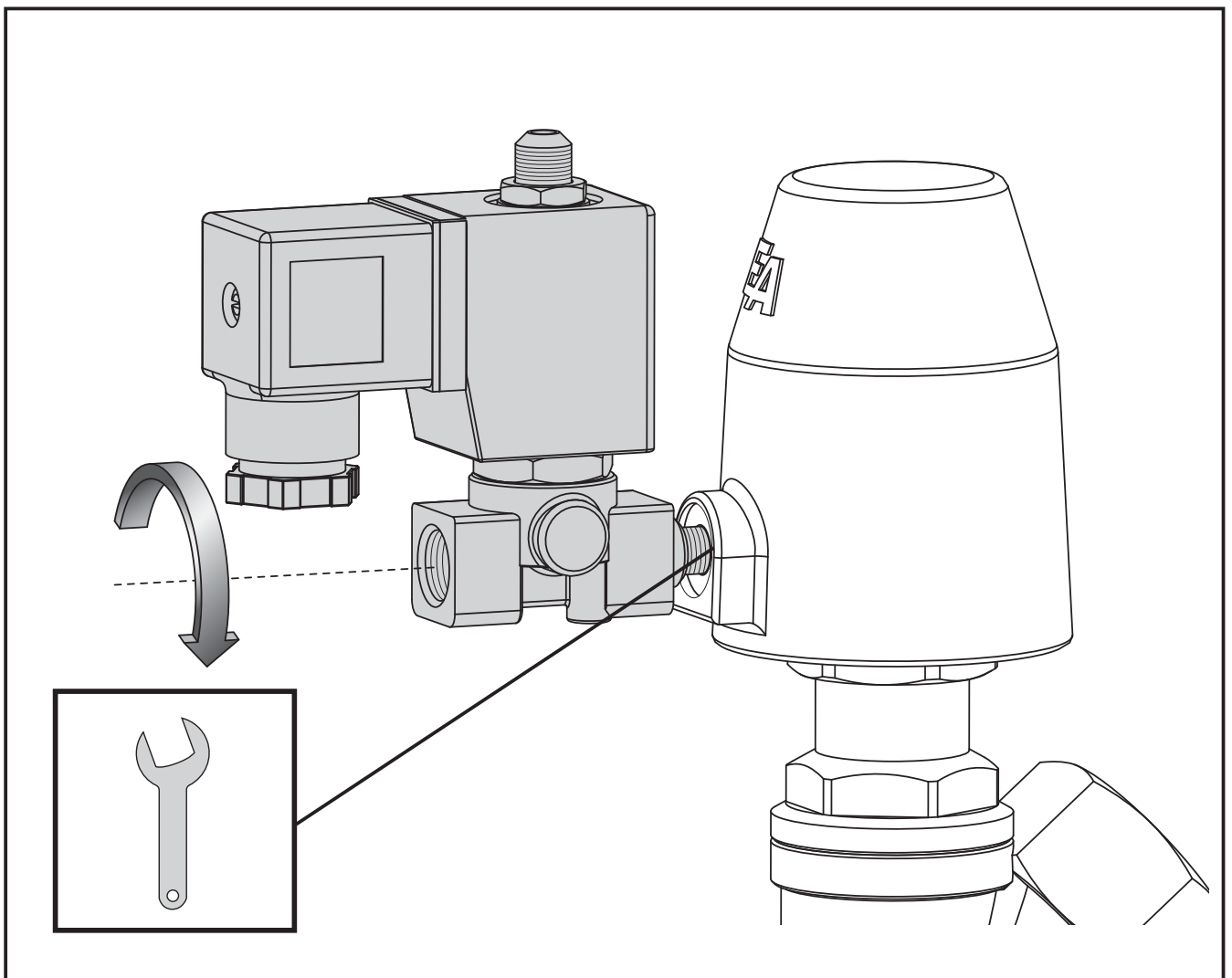

Fig. 5.7 - Mounting / disassemble - Mounting of a pilot valve

5.5.2 Electrical installation of a pilot valve



Turn out the screw from the plug and push up the plug from the valve. Now open the plug.



By electrical installation of the pilot valve use only the prescribed cable type.



Remove the sheaths of the cable and remove the isolation of the leads. In case of leads with stranded conductors, provide the ends in each case with a wire end sleeve.



Lead the cable through the PG screw fitting.



Put the leads end into the terminals and tighten the screw. The correct joining you will see in the wiring diagram.



Take care that no bare lead stand out from the terminals thus preventing the danger of a shock or a short circuit.



Mount the plug. Take care that no lead will be squeezed. The cover of the body can be fixed with 90° turn.



Screw up the PG screw fitting so firmly that the strain relief is effective and the cable feed-through corresponds to the prescribed degree protection.



Put the plug onto the pilot valve and tighten the screw. Take care about the correct position of the plug contacts.

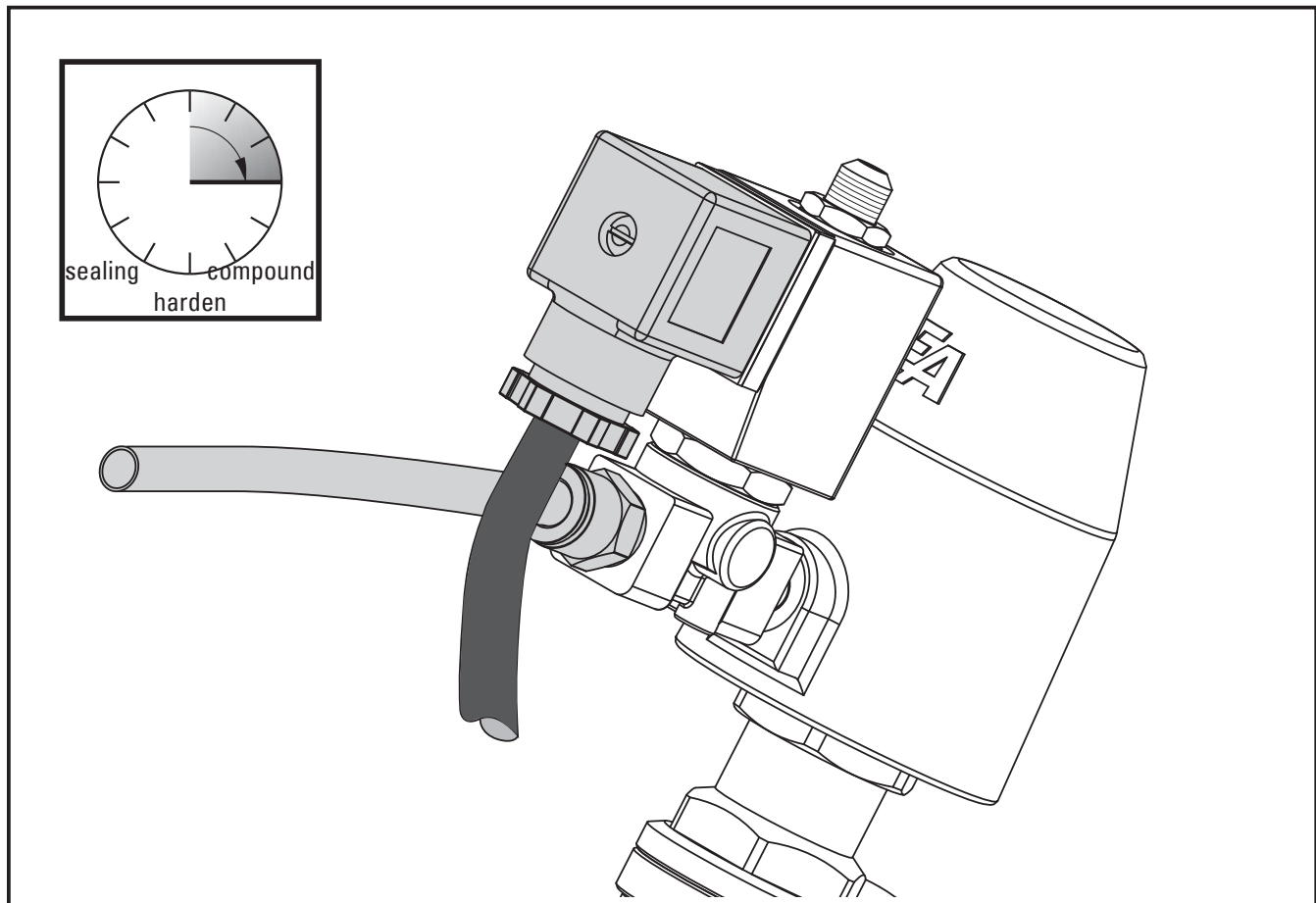

Fig. 5.8 - Mounting / Disassembly - Mounting of a pilot valve, pneumatically and electrical installation

5.6 Electrical installation of a position indicator (Option)



This chapter describe only the installation of the electrical-/mechanical limit switches. The other limit switches will have a connecting cable as standard. In this case the installation must correspond to the environmental conditions.



Open the the housing of the limit switch , by turning out the screws from the cap.



Turn out one fastener and substitute it with a PG screw fitting.



By electrical installation of the limit switch use only the prescribed cable type.



Remove the sheaths of the cable and remove the isolation of the leads. In case of leads with stranded conductors, provide the ends in each case with a wire end sleeve.



Lead the cable through the PG screw fitting.



Put the leads end into the terminals and tighten the screws. The correct joining you will see in the wiring diagram.



Take care that no bare lead stand out from the terminals thus preventing the danger of a shock or a short circuit .



Screw up the PG screw fitting so firmly that the strain relief is effective and the cable feed-through corresponds to the prescribed degree of protection.



Mount the cap of the limit switch. Take care that on lead will be squeezed. Tighten the screws of the cap.

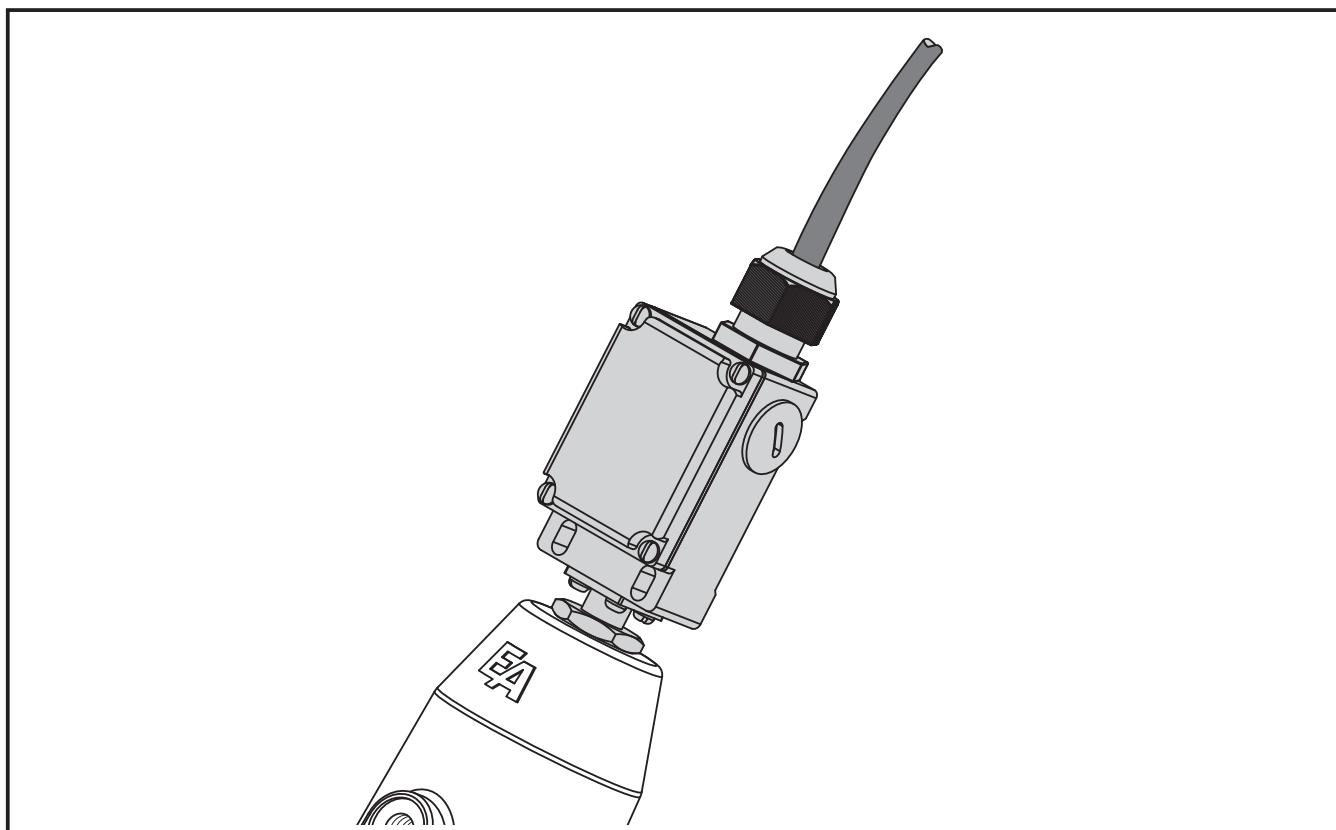

Fig. 5.8 - Mounting / Disassembly - electrical installation of a position indicator

5.7 Disassembly

Although the disassembly of a pressure actuated valve in principle proceeds in the reverse sequence to the mounting; some essential points should be clarified!

- Will the valve to be disassembled be replaced immediately by another?
- Could the valve remain in the pipe?
- If appropriate, does the production process of the plant need to be stopped?
- Is it necessary to inform specific personnel about the disassembly? etc.



Switch off the power and pilot media supply of the device / machine / plant.

Stop the medium. Never remove the armature under pressure.



If necessary, set up warning signs in order to prevent

- **the inadvertent starting up of the devices / machines / plants, or**
- **the switching on of the pilot media supply, or**
- **the switching on of the medium.**



Keep ready some fit tanks to catch up leaking liquids.

5.7.1 Electrical disassembly (Option)



Switch off the power supply and take care to prevent the inadvertent switching on.



Open the housing cover by turning out the screws.



Loosen the screws of the terminal and pull the leads out of the terminals.



Loosen the PG screw fittings and pull the cable out of the device.



Isolate the bare leads end if the cables are not also being disassembled or are not to be immediately reconnected to another actuator.

5.7.2 Mechanical disassembly



Switch of the pilot media, release the pressure in the pipes and take care to prevent the inadvertent switching on.



Loosen the fitting of the pilot medium and take away the pipe of the pilot medium.



Close the pipe of the pilot medium if the pipe is not also being disassembled or is not to be immediately reconnected to another device.



Check up the remaining of the valve body in the pipe. If the valve body must be disassembled loose the flanged connection or screw the pipes out of the valve body.



Don't use the top of the valve as a lever.



Also close the pipes if the pipes are not also being disassembled or are not to be immediately reconnected to another valve.

6. Adjustment

Before starting the pressure actuated valve DG2D, you have to read



→ 3.Safety advice

If you have not do this until now, read these important advices now and turn back to this page..

The following description base on the supposition, that the pressure actuated valve is mounted.

6.1 Stroke stop (Option)

If your pressure actuated valve will have an stroke stop, you are able to limited the stroke in the valve. Therefore you can regulate the flow rate of the valve.



Loosen the locking nut with a spanner.



Turn the set screw:

- clockwise, to decrease the flow rate,
- counter-clockwise, to increase the flow rate.



Check the adjustment and if necessary correct it.



Save the set screw by tighten the locking nut. Make sure, that the set screw does not turn.

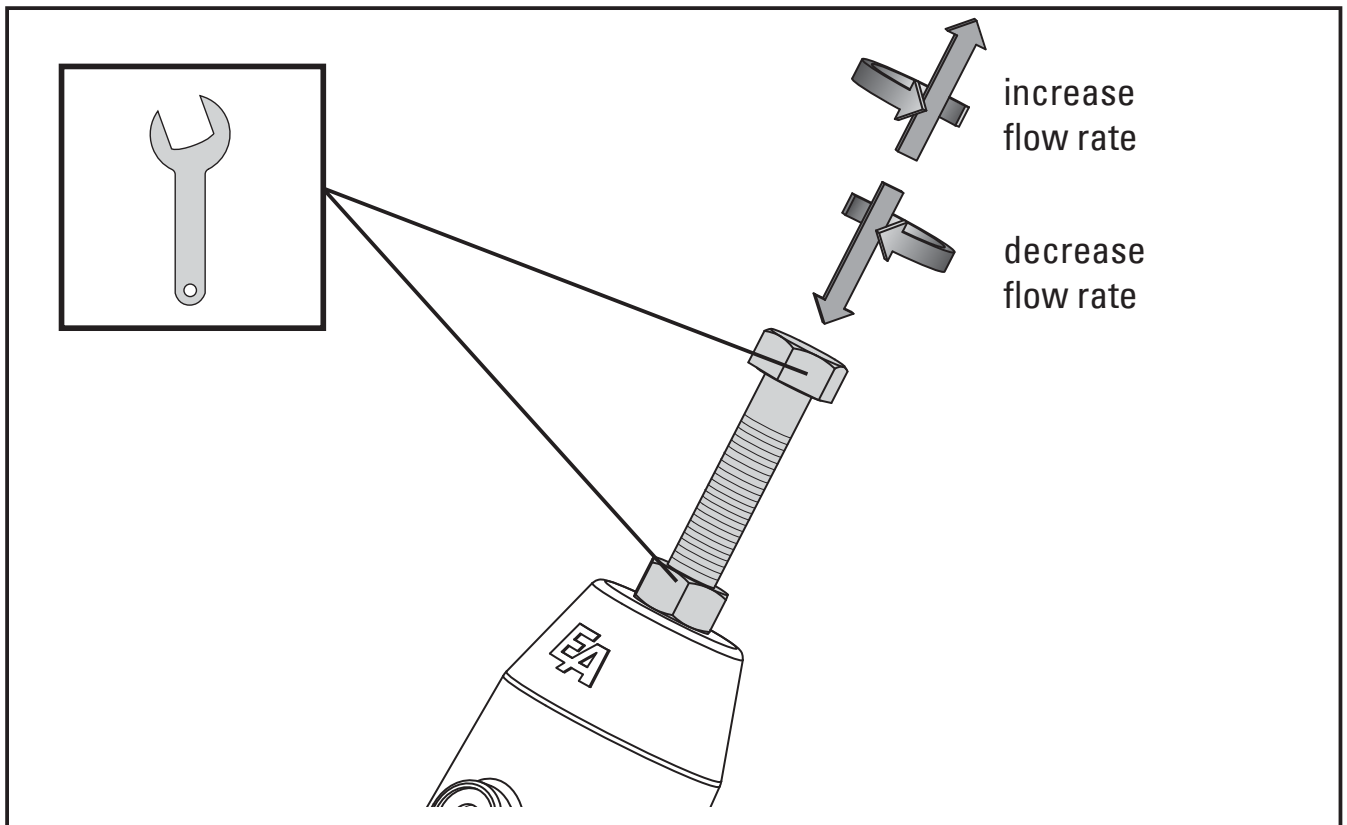

Fig. 6.1 - Adjustment / starting - Adjustment of the stroke stop

6.2 Starting

Before starting the pressure actuated valve DG2D, you have to read



→ 3.Safety advice

If you have not do this until now, read these important advices now and turn back to this page.



The starting of a pressure actuated valve, which is mounted in a plant (e.g. in a refinery or in a chemical plant) should only happen in accordance with the instructions of the hole plant!



Switch on the supplying with compressed air and the voltage of control.



Actuate the pressure actuated valve by hand with the control and check the correct function of the valve.



Check all pipe connections for tightness.



Check all the pilot lead for tightness.



Check the function of the accessory units.

7 Emergency operation with manual override (Option)



If your pressure acting valve will have a manual override, the valve could be open by hand in case of a breakdown of the pilot pressure or the pilot power supply.



The manual override should only be actuated, if there is no pilot pressure in the valve. While automatic running the hand wheel must be set in the closed position.



If necessary, inform the shift foreman / safety engineer or the manager about the disturbance without delay in order, for example, to avoid an outflow / overflow of chemicals or a discharge of gases in good time by means of suitable measures!



The following description based on a view looking on the top of the pilot cylinder of the pressure acting valve.



Turn the hand wheel clockwise to close the valve.



Turn the hand wheel counter-clockwise to open the valve.

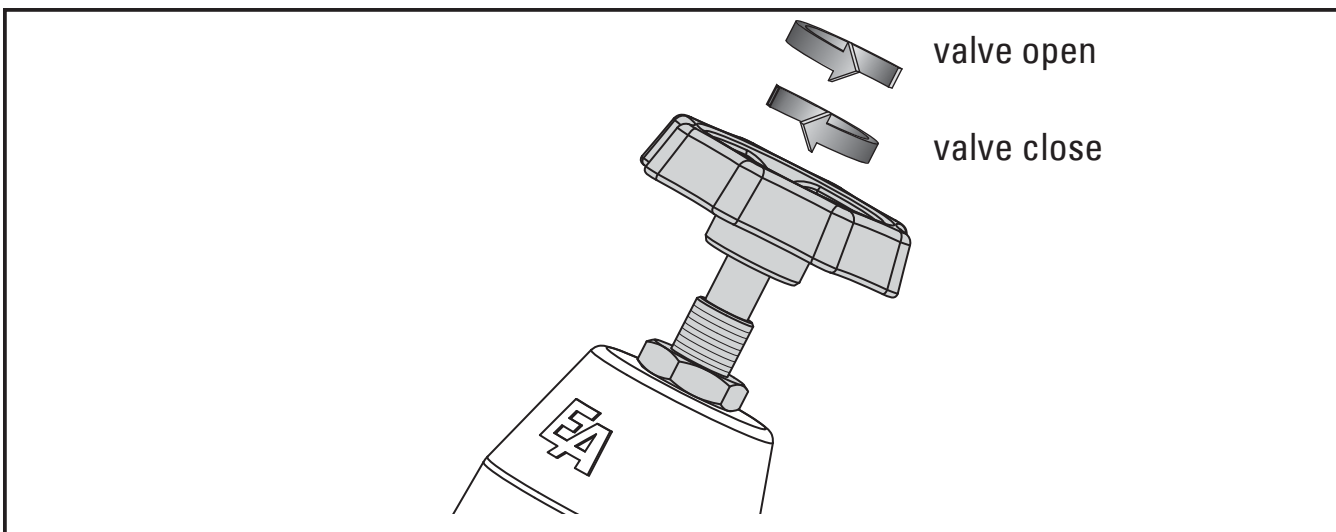

Fig. 7.1 - Emergency operation

8 Failure



If during, the test run or during operation a functional fault of the pressure actuated valve should occur you are requested to open the valve (in an emergency) with the (optional) manual override by hand.

For this observe chapter:

→ 7. Emergency operation with manual override



If necessary, inform the shift foreman / safety engineer or the manager about the disturbance without delay in order, for example, to avoid an outflow / overflow of chemicals or a discharge of gases in good time by means of suitable measures!

Next, using the following list (8.1 Failure causes), attempt to find the reason for the causes of the failure and, if it lies within your capabilities, to correct this.



Do not try to repair the pressure actuated valve!

Isolate the failed pressure actuated valve from the power supply and disconnect the pilot pressure port!

In case of defect in the valve make contact with the supplier.

The telephone number will be found on the back cover of these mounting and installation manual.

8.1 Failure causes

- Is the power supply to the control switched on?
- Is the device for the compressed-air switched on?
- Are the leads from the controller to the pressure actuated valve undamaged?
- Are the leads from the controller to the pilot valve undamaged?

9 Maintenance / Cleaning

9.1 Maintenance

On normal accounts the pressure actuated valve DG2D is maintenance free.



Check in regular turns the tightness of the pressure actuated valve DG2D.

In case of a defect in the valve make contact with the supplier. The telephone number will be found on the back cover of these operation and installation manual.



If you determinate that there is a damage to the valve, isolate it from the pilot pressure and the power supply. However, before doing this, it is essential to refer to the

→ **Safety advice (Chapter 3).**

9.2 Cleaning



Clean the body of the valve as required using a slightly moistened, soft cloth and a normal household cleaner.



Do not use any abrasive corrosive or flammable cleaning agents!



Do not use any high pressure cleaning devices!



Prevent moisture or liquid penetrating into the interior of the pilot cylinder.

10 Technical data

10.1 Technical data DG2D1xx

DESIGN	Seat valve with disk sealing
OPERATION	<ol style="list-style-type: none"> 1. Normally close with flow direction. Opened by pilot pressure. (please observe the advice on page 14) 2. Normally close against flow direction. Opened by pilot pressure 3. Normally open. Closed by pilot pressure against flow direction 4. Double acting Opened and closed by pilot pressure
MATERIAL	Body: Brass Inner parts: Stainless steel, Brass Pilot cylinder: Brass Stem sealing: NBR
CONNECTION	threaded connection G ^{1/2} up to G 3 (DIN ISO 228 T1)
PILOT PORT	G ^{1/8} (DIN ISO 228 T1)Piston-Ø: 50mm - 80mm G ^{1/4} (DIN ISO 228 T1)Piston-Ø: 125mm
PILOT PRESSURE	2 - 10 bar
MEDIA	neutral gases and liquids up to 400 mm ² /s
TEMPERATURE RANGE	-10°C up to +90°C
AMBIENTE TEMPERATURE	max. +60°C
PILOT MEDIA	Air, water (oil on request)
INSTALLATION	as desired
OPTIONS	Optical position indicator, electrical position indicator, manuel override, stroke stop, free of oil and grease, vacuum version

MEDIA PRESSURE see table, pressure specifications in [bar]

Operation	Normally close with the flow direction					Normally close against the flow direction					Normally open against the flow direction			
	Piston-Ø [mm]					Piston-Ø [mm]					Piston-Ø [mm]			
Connection	32	50	63	80	125	32	50	63	80	125	50	63	80	125
G ^{1/2}	16	16	-	-	-	10	16	-	-	-	16	-	-	-
G ^{3/4}	12	16	-	-	-	6	12	-	-	-	16	-	-	-
G 1	6,5	16	16	16	-	3	8	16	16	-	16	16	16	-
G 1 ^{1/4}	-	10	16	16	-	-	4	10	16	-	8	15	16	-
G 1 ^{1/2}	-	8	12	16	-	-	2	8	16	-	6	10	16	-
G 2	-	5	8	16	16	-	0,5	4,5	8	12	3	6	12	16
G 2 ^{1/2}	-	-	4,5	7	16	-	-	2	2,5	6	-	3	5	16
G 3	-	-	3	5	12	-	-	1	1,5	4	-	2	3	10

10.2 Technical data DG2D2xx

DESIGN	Seat valve with disk sealing
OPERATIONS	<ol style="list-style-type: none"> 1. Normally close with the flow direction Opened by pilot pressure (please observe the advice on page 14) 2. Normally close against flow direction Opened by pilot pressure 3. Normally open against flow direction Closed by pilot pressure 4. Double acting Opened and closed by pilot pressure
MATERIALS	Body: bronze, from G 2 ¹ / ₂ brass Inner parts: Stainless steel, brass Pilot cylinder: brass nickel-plated Stem sealing: PTFE
CONNECTION	threaded connection G ¹ / ₂ up to G 3 (DIN ISO 228 T1)
PILOT PORT	G ¹ / ₈ (DIN ISO 228 T1)Piston-Ø: 50mm - 80mm G ¹ / ₄ (DIN ISO 228 T1)Piston-Ø: 125mm
PILOT PRESSURE	2 - 10 bar
MEDIA	neutral gases and liquids up to 400 mm ² /s
TEMPERATURE RANGE	-30°C up to +180°C
AMBIENTE TEMPERATURE	max. +60°C
PILOT MEDIA	air, water (oil on request)
INSTALLATION	as desired
OPTIONS	Optical position indicator; electrical position indicator; position indication by inductive proximity switch; manual override; stroke stop; free of oil and grease; hygienic version (food)

MEDIA PRESSURE see table, pressure specifications in [bar]

Operation	Normally close with the flow direction					Normally close against the flow direction					Normally open against the flow direction			
	Piston-Ø [mm]					Piston-Ø [mm]					Piston-Ø [mm]			
Connection	32	50	63	80	125	32	50	63	80	125	50	63	80	125
G ¹ / ₂	16	16	-	-	-	10	16	-	-	-	16	-	-	-
G ³ / ₄	12	16	-	-	-	6	12	-	-	-	16	-	-	-
G 1	6,5	16	16	16	-	3	8	16	16	-	16	16	16	-
G 1 ¹ / ₄	-	10	16	16	-	-	4	10	16	-	8	15	16	-
G 1 ¹ / ₂	-	8	12	16	-	-	2	8	16	-	6	10	16	-
G 2	-	5	8	16	16	-	0,5	4,5	8	12	3	6	12	16
G 2 ¹ / ₂	-	-	4,5	7	16	-	-	2	2,5	6	-	3	5	16
G 3	-	-	3	5	12	-	-	1	1,5	4	-	2	3	10

10.3 Technical data DG2D3xx, DA2D3xx, DL2D3xx, DM2D3xx, DF2D3xx

DESIGN	Seat valve with disk sealing
OPERATIONS	<ol style="list-style-type: none"> 1. Normally close with flow direction Opened by pilot pressure (please observe the advice on page 14) 2. Normally close against flow direction Opened by pilot pressure 3. Normally open against flow direction Closed by pilot pressure 4. Double acting Opened and closed by pilot pressure
Material	Body: Stainless steel Inner parts: Stainless steel Pilot cylinder: Stainless steel or brass chrome-plated SK125: Al or stainless steel Stem sealing: PTFE
CONNECTION	threaded connection G $\frac{1}{2}$ up to G 3 (DIN ISO 228 T1) butt weld DN 15 up to DN 80 (ISO 4200, DIN 11850-R2, DIN3239 - only up to DN50) flanges PN 40 (DN65 + DN80 : PN 16) flanges PN 16 - DN65 will be delivered in 4-hole execution!
PILOT PORT	G $\frac{1}{8}$ (DIN ISO 228 T1)Piston-Ø: 50mm - 80mm G $\frac{1}{4}$ (DIN ISO 228 T1)Piston-Ø: 125mm
PILOT PRESSURE	2 - 10 bar, standard 6 - 10 bar, others on request
MEDIA	gases and liquids up to 400 mm ² /s (aggressive media on request)
TEMPERATURE RANGE	-30°C up to +180°C
AMBIENTE TEMPERATURE	max. +80°C
PILOT MEDIA	Air, water (oil on request)
INSTALLATION	as desired
OPTIONS	Optical position indicator; electrical position indicator; position indication by inductive proximity switch; manual override; stroke stop; free of oil and grease; hygienic version (food)
MEDIA PRESSURE	see table, pressure specifications in [bar]

Operation	Normally close with the flow direction					Normally close against the flow direction					Normally open against the flow direction			
	Piston-Ø [mm]					Piston-Ø [mm]					Piston-Ø [mm]			
Connection	32	50	63	80	125	32	50	63	80	125	50	63	80	125
G $\frac{1}{2}$ DN 15	16	25	40	-	-	10	25	-	-	-	40	40	-	-
G $\frac{3}{4}$ DN 20	12	25	40	-	-	6	12	-	-	-	25	40	-	-
G 1 DN 25	6,5	18	25	40	-	3	8	18	32	-	16	25	40	-
G $1\frac{1}{4}$ DN 32	-	10	16	30	-	-	4	10	20	-	8	15	25	-
G $1\frac{1}{2}$ DN 40	-	8	12	20	-	-	2	8	15	-	6	10	18	-
G 2 DN 50	-	5	8	14	30	-	0,5	4,5	8	12	3	6	12	30
G $2\frac{1}{2}$ DN 65	-	-	4,5	7	16	-	-	2	2,5	8,5	-	3	5	16
G 3 DN 80	-	-	3	5	12	-	-	1	1,5	6	-	2	3	10

10.4 Technical data DG3D3xx

DESIGN	Seat valve with disc sealing
OPERATIONS	1. Split function 2. Mixing function
MATERIAL	Body: Stainless steel 1.4408 Inner parts: Stainless steel Pilot cylinder: Brass chrome-plated / Stainless steel Stem sealing: PTFE
CONNECTION	Threaded connection G ^{1/2} ... G 2 (DIN ISO 228 T1)
PILOT PORT	G ^{1/8} (DIN ISO 228 T1)
PILOT PRESSURE	2 ... 10bar (standard 6 ... 10bar) others on request
MEDIA	gases and liquids up to 400 mm ² /s
TEMPERATURE RANGE	-20°C ... +180°C
AMBIENTE TEMPERATURE	max. +60°C
PILOT MEDIA	Air, water (oil on request)
INSTALLATION	optional, observe flow direction
OPTIONS	Optical position indicator, electrical position indicator, manual override, free of oil and grease, vacuum-version
MEDIA PRESSURE	see table, pressure specifications in [bar]

Max. media pressure [bar] at 6 bar pilot pressure				
Connection	Piston- Ø			
	50 [mm]	63 [mm]	80 [mm]	125 [mm]
["]				
G ^{1/2}	10	22	-	-
G ^{3/4}	8	18	30	-
G 1	5	12	25	-
G 1 ^{1/4}	-	4	12	16
G 1 ^{1/2}	-	4	8	12
G 2	-	2,5	5	8

10.5 Technical data DF3Dxx

DESIGN	Seat valve with disc sealing
OPERATIONS	1. Split function 2. Mixing function
MATERIAL	Body: GG-25 Inner parts: Brass and stainless steel Pilot cylinder: Brass chrome-platede / Aluminium alloy with brass cylinder (Sk-Ø 125) Stem seal: PTFE
CONNECTION	Flanges PN16 Flanges PN16 - DN65 will be delivered in 4-hole execution
PILOT PORT	G 1/8 (DIN ISO 228 T1)
PILOT PRESSURE	2 ... 10bar (standard 6 ... 10bar) others on request
MEDIA	gases and liquids up to 400 mm ² /s
TEMPERATURE RANGE	-10°C ... +180°C
AMBIENT TEMPERATURE	max. +60°C
PILOT MEDIA	Air, water (oil on request)
INSTALLATION	optional, observe flow direction
OPTIONS	on request
MAX. MEDIA PRESSURE	Body made of GG-25: max. 16 bar (at 6 bar pilot pressure)



Qualität von Anfang an.

(1) **Declaration in conformity**
(2) **as defined by Pressure-Equipment-Directive 97/23/EG**

(3) Herewith we declare that the supplied articles:

DG2D, DG3D, DA2D, DL2D, DM2D, DF2D, DF2Z and all variations of these articles

(4) of the company **END-Automation GmbH & Co. KG**
D-32547 Bad Oeynhausen
Germany

(5) are in conformity with the regulations of the directive 97/23/EC.

(6) Applied conformity assessment PED: Modul H

(7) Notified body for conformity assessment PED and Quality-Management-System:



Bureau Veritas S.A.
Paris / Frankreich
Kennzeichen 0062

(8) Applied harmonized standards, in particular:

DIN 3840:1982

**Armaturengehäuse
Festigkeitsberechnung gegen Innendruck**

(9) on behalf

Friedhelm König
Technical manager



END-Automation GmbH & Co. KG
Oberbecksener Str. 78
32547 Bad Oeynhausen · Germany
Telefon: +49 (0)5731 - 7901-0
Telefax: +49 (0)5731 - 7901-98
<http://www.end.de> post@end.de

Bad Oeynhausen, 28. Mai 2002

Michael End
Quality manager



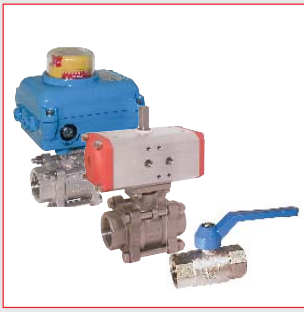

Qualität von Anfang an.

Qualität von Anfang an.

END-Armaturen GmbH & Co. KG
 Oberbecksener Str.78
 D-32547 Bad Oeynhausen
 Postfach (PLZ 32503) 100 341
 Telefon +49 (0) 5731 / 7900-0
 Telefax +49 (0) 5731 / 7900-199
 Internet <http://www.end.de>
 E-Mail post@end.de

END-Automation GmbH & Co. KG
 Oberbecksener Str.78
 D-32547 Bad Oeynhausen
 Postfach (PLZ 32503) 100 342
 Telefon +49 (0) 5731 / 7901-0
 Telefax +49 (0) 5731 / 7901-999
 Internet <http://www.end.de>
 E-Mail post@end.de

Watergates GmbH & Co. KG
 Oberbecksener Str.70
 D-32547 Bad Oeynhausen
 Postfach (PLZ 32503) 100 321
 Telefon +49 (0) 5731 / 7900-0
 Telefax +49 (0) 5731 / 7900-199
 Internet <http://www.watergates.de>
 E-Mail post@watergates.de



N° INT80209DE