



*Qualität von Anfang an.*

# Installation and Operation

**SE Series Electric Actuator**

**as**

**EL**



END-Armaturen GmbH & Co. KG

Postfach (PLZ 32503) 100 341 · Oberbecksener Str. 78 · D-32547 Bad Oeynhausen · Telefon (05731) 7900-0 · Telefax (05731) 7900-80 · <http://www.end.de>

## EA Electric Actuators.....

EA electric actuators are the most advanced actuators of their type on the market today, this achievement is due to many years of improvement and development. Basic actuators provide all the features normally required for modern plant automation and a wide range of control options are available to tailor actuators to individual applications.

The basic operation of EA valve actuators is the same for all sizes. Models EL20 through EL2500 feature a disengageable manual override. Torque switches are standard on models EL100 - EL2500. A double reduction worm/worm gear system is utilized on models EL20 to EL150. The EL200 through EL2500 utilize an extra spur gear reduction on the motor shaft.

## Where to Find Information

	Page
Installation Tips	2
Parts and Materials	
- EL20	4
- EL55	6
- EL100/150	8
- EL200/350	10
- EL500/800	12
- EL1200/1600	14
- EL2500	16
Installation, Setting and Calibration	
- Mechanical Limit Stop Setting	18
- Limit Switch Setting	19
- Potentiometer	20
- Speed Controller	21
- Position Transmitter, 2 Wire	22
- Position Transmitter, 4 Wire	24
- Positioner	26
- Plug and Socket	29
- Local Control Station	31
Disassembly and Re-assembly	33
Trouble Shooting	34
Wiring Diagrams	35
- Index	35
- Basic Actuators	36
- Kit Options	38
Notes and Up-dates	42
Dimensions and Performance data	43

# Installation

---

## CAUTION

Do not attempt to store, install, or operate your EL actuator without taking account of the following;

## ELECTRICAL WIRING

The control circuitry feeding the actuator must not allow power to be supplied to both “open” and “close” motor windings at the same instance in time. For example, when power is applied to the “open” terminal, the “close” terminal must be isolated from the power supply and vice versa. Failure to do so will result in the motor overheating.

If several actuators are controlled from a common control switch, which has only a D.P.D.T. type electrical contact on it, then the result can be that the actuators will run in different directions.

For example: An open/stop/close switch with only D.P.D.T. contacts on it controls three actuators. When the switch is turned to the open control position, all three actuators will start to run open. If any one of the three actuators reaches its open position before the other two it can receive power via the common D.P.D.T. contacts and the other actuators close motor winding, resulting in that actuator running closed.

When several actuators are required to be controlled in parallel with one 3-position switch, that switch must have separate contacts for each actuator being controlled.

## Also:

1. Use wire with proper gauge and insulation. (follow standards prescribed by the relevant electrical code)
2. Actuator chassis must be correctly grounded.
3. Use appropriate conduit or cable glands for weather proof or explosion proof applications.
4. Follow the wiring diagram to ensure proper connection of power and control voltage to the actuator.
5. Make all splices or connections using the correct pin connector or terminal strip.
6. Always connect anti condensation heater.

## STORAGE

### Warehouse Storage

1. Actuators should be stored in a clean, dry warehouse free from excessive vibration and rapid temperature change.
2. Actuators should not be stored on any floor surface.
3. In areas of high humidity the actuator should have a packet of desiccant placed in the motor compartment. (this will absorb excessive moisture)

### On Site Storage

1. Actuators should be stored in a clean, dry location free from excessive vibration and rapid temperature change.
2. Ensure all actuator covers are in place and securely fastened.
3. If power is not available, place a packet of desiccant in the motor compartment. (replace cover and securely fasten)
4. Replace plastic conduit plugs with appropriate pipe plugs.

Failure to follow proper storage guidelines will void warranty.

## DO

1. Keep motor compartment clean and dry.
2. When applicable connect the compartment heater. (not fitted on EL20)
3. Check unit wiring and ensure it coincides with the proper wiring diagram.
4. Power supply should be free from excessive voltage transients (spikes).
5. Control lines should be shielded properly.
6. CAUTION: Shut off incoming power before installing or repairing any electrical device.
7. Check motor nameplate to be certain that the actuator voltage is the same as your incoming voltage.
8. Schedule a periodic maintenance check of all actuators to prolong life and ensure proper performance. (we suggest check for correct opening and closing once a month)
9. Set open and close limit switches manually, in accordance with instructions. (see page 19)
10. Be sure and lubricate unit during reassembly. (see LUBRICATION)
11. Check limit switch setting prior to motor operation if the actuator has been repaired or disassembled.

## DON'T.

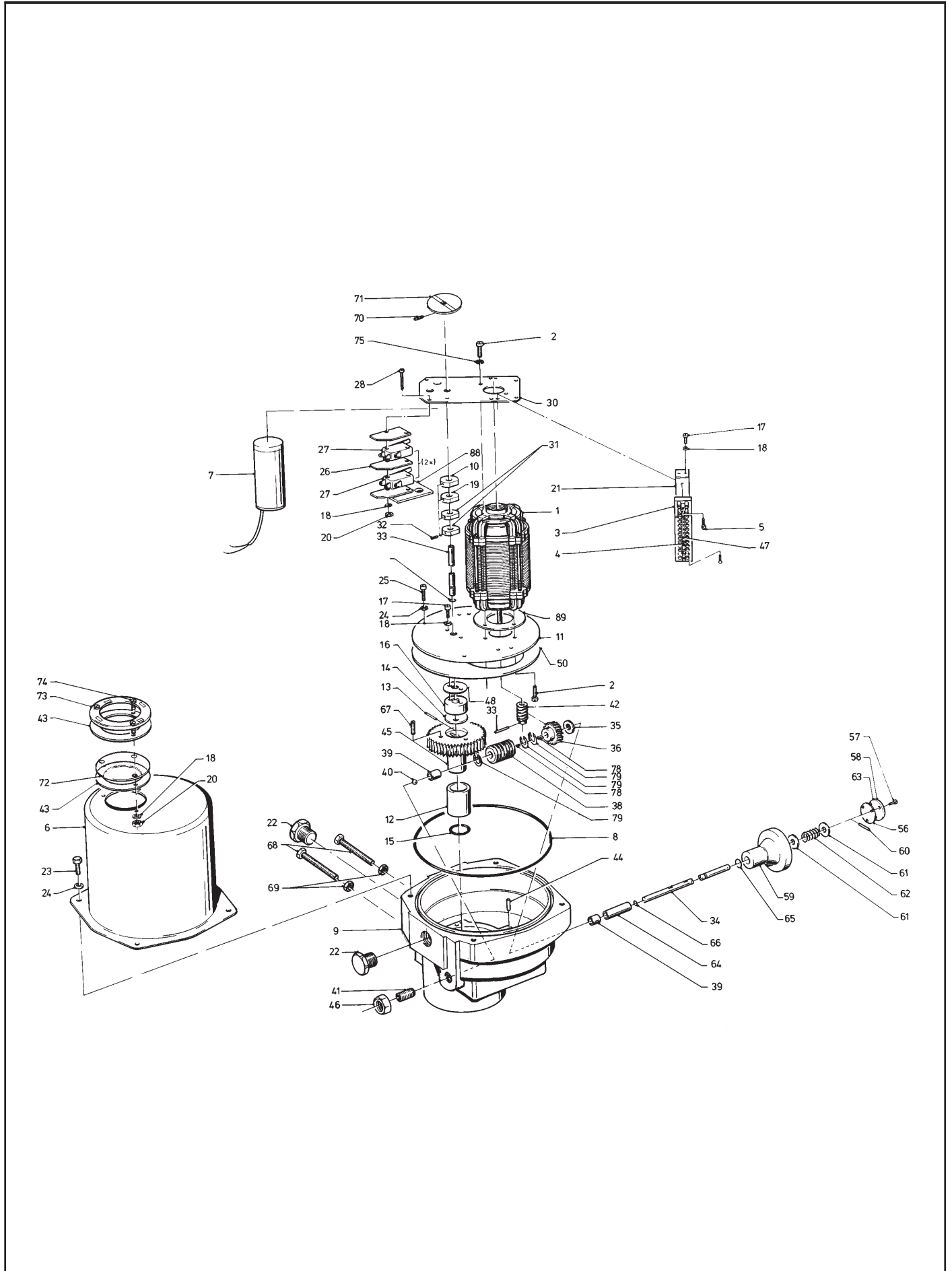
1. CAUTION: Do not attempt to install or repair any electric device without shutting off incoming power.
2. Do not operate valve without first setting limit switches and checking direction of motor rotation.
3. Release torque before disassembling gear train components or the actuator from the valve.
4. Do not adjust torque switch settings. (these are factory set and need no adjustment)
5. Do not use a cheater or extension bar on the handwheel. (this could result in damage to the valve assembly or cause physical injury)
6. Do not alternately start and stop motor to seat or un-seat a valve. If properly sized, the running torque of the actuator should seat the valve in normal operation.

## LUBRICATION

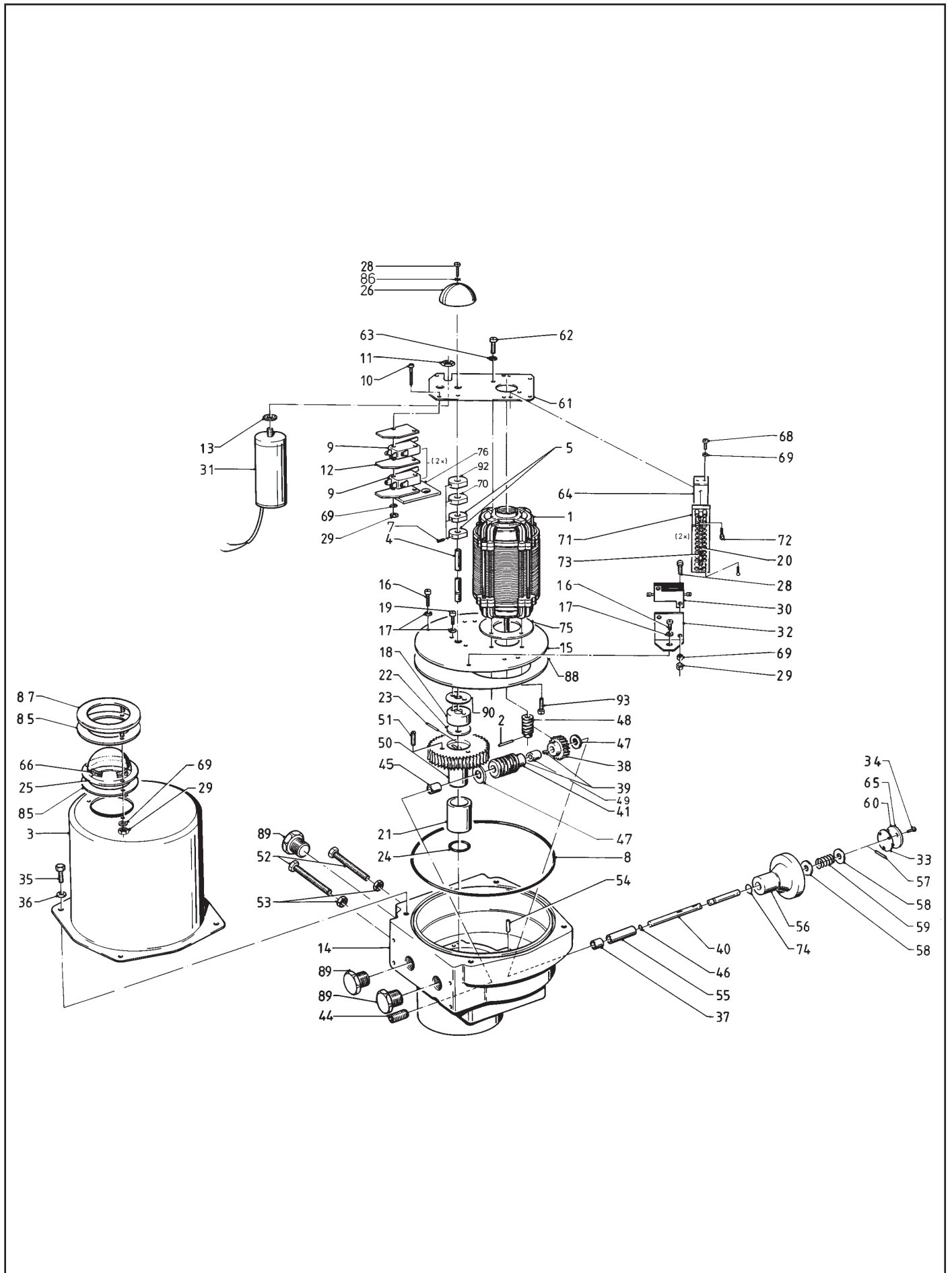
EA utilizes a totally sealed and permanently lubricated gear case. The actuator can be mounted in any position. It is not unusual to find a very small amount of lubricant weeping around shaft seals. This situation can occur during long periods of storage. This lubrication will not affect operation and should simply be wiped up with a clean cloth. Once equipment has begun operating, this weeping should disappear.

The actuator gearbox is filled with FINA CERAN M (MO S<sub>2</sub>). This standard lubricant has been proven extremely reliable. Should the gearbox be disassembled, repack with EP370 or any good quality mineral based gear grease.

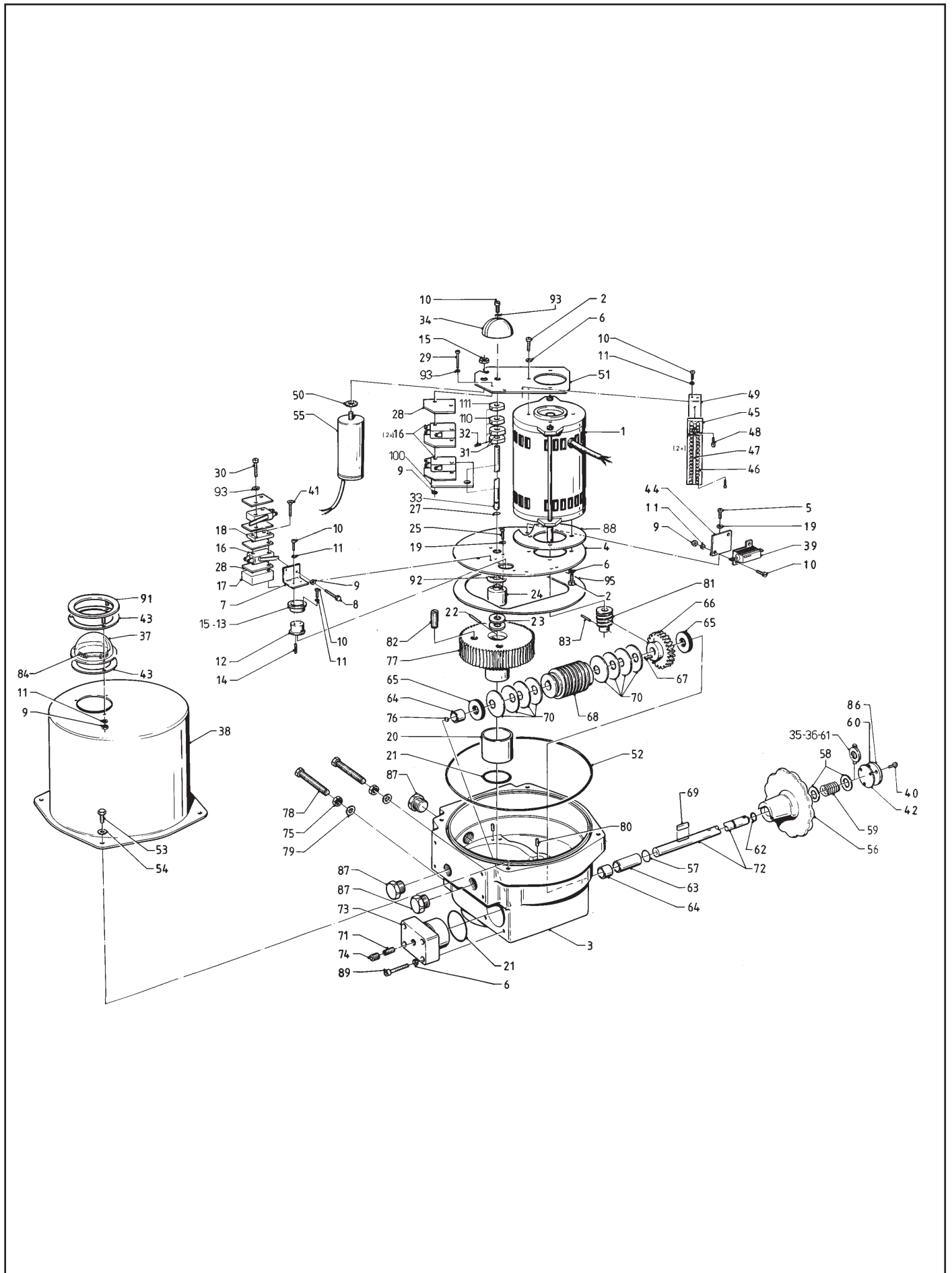
- ie. DROPPING POINT: > 300 °C.  
BASE: Calcium Sulphate.  
CLASSIFICATION :NLGI Class 1.



PC.NO.	QTY.	DESCRIPTION.	MATERIAL.	PC.NO.	QTY.	DESCRIPTION.	MATERIAL.
1	1	Motor		71	1	Dial	Steel
2	4	Screw	Steel	72	1	Window	Lexan
3	1	Terminal Block		73	1	Window Holder	Steel
4	1	Marking Tag		74	3	Screw	Steel
5	2	Screw	Steel	75	4	Lockwasher	Steel
6	1	Cover	Steel	77	4	Washer	Steel
7	1	Capacitor		78	2	Key	Steel
8	1	O-Ring		79	3	Retaining Ring	Steel
9	1	Housing	Aluminium	88	1	Support Plate L.S.	Steel
10	1	Limitswitch Cam	Aluminium	89	1	Gasket Motor	
11	1	Motor Support Plate	Steel				
12	1	Drive Sleeve Bearing	Steel				
13	1	Pin	Steel				
14	1	Spring	Steel				
15	1	O-Ring	Buna				
16	1	Top Bearing	Steel				
17	4	Screw	Steel				
18	11	Lockwasher	Steel				
19	1	Limitswitch Cam	Aluminium				
20	7	Hex Nut	Steel				
21	1	Terminal Bracket	Steel				
22	2	Blindstop	Bronze				
23	4	Screw	Steel				
24	9	Lock Washer	Steel				
25	5	Screw	Steel				
26	5	Isolation Plate					
27	4	Micro Switch					
28	2	Screw	Steel				
29	2	Lock Washer	Steel				
30	1	Limitswitch Bracket	Steel				
31	2	Limitswitch Cam	Aluminium				
32	4	Screw	Steel				
33	1	Indicator Shaft	Steel				
34	1	Wormshaft	Steel				
35	1	Thrustbearing	Steel				
36	1	Worm Wheel	Bronze				
38	1	Worm	Steel				
39	2	Bearing	Steel				
40	1	Ball	Steel				
41	1	Screw	Steel				
42	1	Worm	Steel				
43	2	Gasket Window	Rubber				
44	2	Pin	Steel				
45	1	Drive Sleeve	Cast Iron				
46	1	Hex nut	Steel				
47	1	Sticker Terminal					
48	1	Gasket Top Bearing					
50	1	Gasket Motor Support Plate					
53	1	Pin	Steel				
56	1	Gasket Handwheel					
57	3	Screw	Steel				
58	1	Sticker Open-close					
59	1	Handwheel	Aluminium				
60	1	Pin	Steel				
61	2	Washer Handwheel	Steel				
62	1	Spring	Steel				
63	1	Handwheel Cover	Steel				
64	1	Bushing	Steel				
65	1	O-Ring	Buna				
66	1	O-Ring	Buna				
67	2	Screw	Steel				
68	2	Screw					
69	2	Hex Nut	Steel				
70	1	Screw					



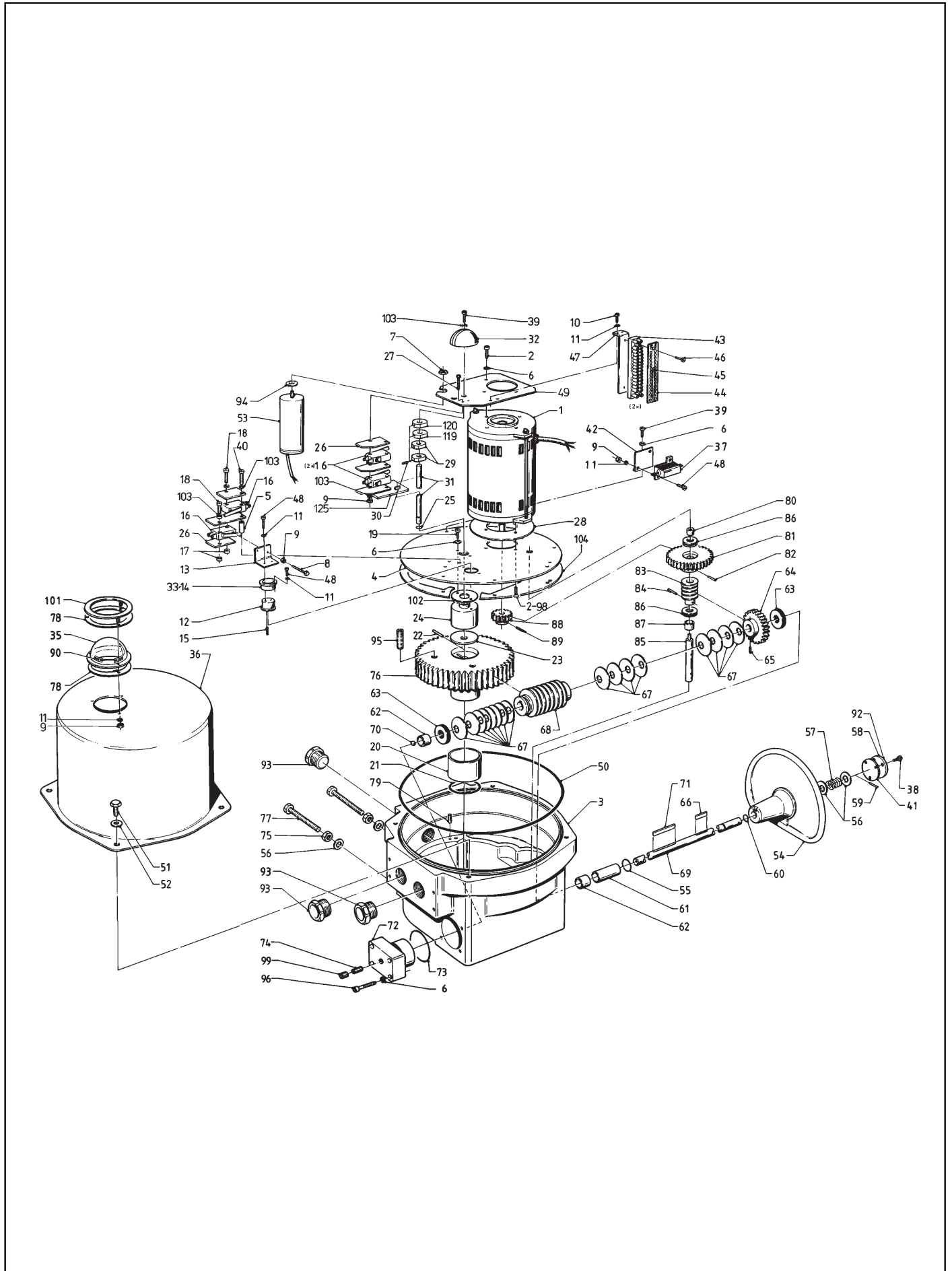
PC.NO.	QTY.	DESCRIPTION.	MATERIAL.	PC.NO.	QTY.	DESCRIPTION.	MATERIAL.
1	1	Motor		68	4	Screw	
2	1	Pin Spiral	Steel	69	9	Lock Washer	
3	1	Cover	Steel	70	1	Limitswitch Cam green	Aluminium
4	1	Indicator Shaft	Steel	71	2	Terminal Block	
5	2	Limit Switch cam	Aluminium	72	4	Screw	
7	4	Screw	Steel	73	2	Marking Tag	
8	1	O-Ring	Buna	74	1	O-Ring	Buna
9	4	Micro Switch		75	1	Sticker Terminal	
10	2	Screw		76	1	Support Plate Switch	Steel
11	1	Nut		85	2	Window gasket	Rubber
12	5	Insulation plate		86	1	Tooth Washer	
13	1	Tooth Washer		87	1	Window Holder	Steel
14	1	Housing	Aluminium	88	1	Motor support plate gasket	
15	1	Motor Support plate	Steel	89	3	Blindstop	
16	7	Screw		90	1	Top Bearing gasket	
17	9	Lock Washer		92	1	Limitswitch Cam Red	Aluminium
18	1	Bearing	Steel	93	4	Screw	
19	2	Screw					
20	1	Sticker Terminal					
21	1	Bearing	Steel				
22	2	Curved Spring washer	Steel				
23	1	Pin Spiral					
24	1	O-Ring	Buna				
25	1	Window	Lexan				
26	1	Dial					
27	1	Motor Gasket					
28	3	Screw					
29	7	Nut					
30	1	Heater					
31	1	Capacitor					
32	1	Heater Bracket	Steel				
33	1	Handwheel gasket					
34	3	Screw					
35	4	Screw					
36	4	Lock Washer					
37	1	Bearing	Bronze				
38	1	Worm Wheel	Bronze				
39	2	Key					
40	1	Worm Shaft	Steel				
41	1	Worm	Steel				
42	1	Retaining Ring	Steel				
44	1	Endcap	Aluminium				
45	1	Bearing	Steel				
46	1	O-Ring	Buna				
47	1	Thrust Bearing	Steel				
48	1	Worm	Steel				
49	1	Spacer	Steel				
50	1	Drive Sleeve	Bronze				
51	2	Screw					
52	2	Screw					
53	2	Nut					
54	2	Dowel Pin					
55	1	Handwheel bearing	Brass				
56	1	Handwheel	Aluminium				
57	1	Pin Spiral					
58	2	Washer					
59	1	Spring					
60	1	Handwheel Cover					
61	1	Limit Switch Bracket	Steel				
62	2	Screw					
63	2	Lock Washer					
64	2	Terminal Bracket					
65	1	Sticker Open/Close					
66	1	Window Sticker					



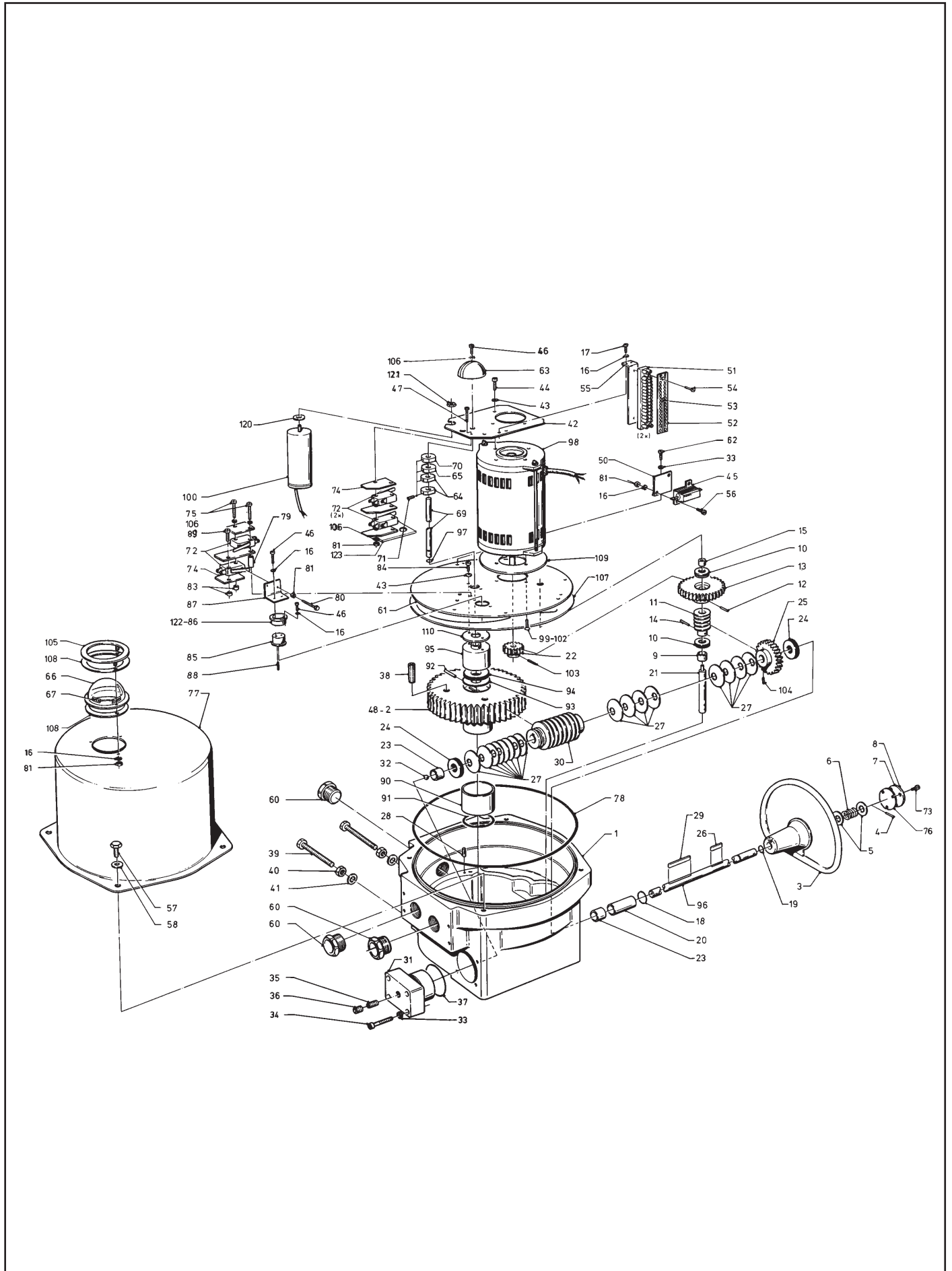
# EL-100/150

# Parts and Materials

PC.NO.	QTY.	DESCRIPTION.	MATERIAL.	PC.NO.	QTY.	DESCRIPTION.	MATERIAL.
1	1	Motor		67	1	Key	Steel
2	7	Screw		68	1	Worm	Steel
3	1	Housing	Aluminium	69	1	Key	
4	1	Motor Support Plate	Steel	70	8	Torque Spring	
5	7	Screw		71	1	Screw	Steel
6	11	Lock Washer		72	1	Worm Shaft	Steel
7	1	Torque Switch Bracket	Steel	73	1	Wormcap	Aluminium
8	2	Screw		74	1	Screw	
9	9	Nut		75	3	Nut	
10	11	Screw		76	1	Ball	Steel
11	13	Lock Washer		77a	1	Drive Sleeve (EL-100)	Cast Iron
12	1	Torque Switch Collar		77b	1	Drive Sleeve (EL-150)	Bronze
13	1	Torque Switch Bush Bearing	Brass	78	2	Screw	
14	1	Dowel Pin		79	2	Plain Washer	
15	1	T.S. Gasket		80	2	Dowel Pin	
16	6	Micro Switch		81	1	Worm	Steel
17	1	Torque Switch Spacer		82	2	Slotted set screw	
18	1	Adaptor		83	1	Pin Spiral	Steel
19	9	Lock Washer		84	1	Window Sticker	
20	1	Drive Sleeve Bearing	Steel	86	1	Sticker Open/Closed	
21	2	O-Ring	Buna	87	3	Blindstop	
22	1	Pin Spiral		88	1	Motor Gasket	
23	2	Top Spring		89	4	Screw	
24	1	Top Bearing	Steel	91	1	Window Holder	
25	2	Screw		92	1	Topbearing gasket	
28	9	Insulation Plate		93	6	Tooth Washer	
29	2	Screw		94	1	Retaining Ring	
30	4	Screw		95	1	Motor support plate gasket	
31	2	Limit Switch Cam	Aluminium	100	1	Support Plate Switch	Steel
32	4	Screw		110	1	Limitswitch Cam Green	Aluminium
33	1	Indicator Shaft	Steel	111	1	Limitswitch Cam Red	Aluminium
34	1	Dial					
35	1	Shimring					
36	1	Retaining Ring					
37	1	Window	Lexan				
38	1	Cover	Steel				
39	1	Heater					
40	3	Screw					
41	2	Screw					
42	1	Handwheel gasket					
43	2	Window gasket					
44	1	Heater Bracket					
45	2	Terminal Block					
46	2	Marking Tag					
47	2	Sticker Terminal No's					
48	4	Screw					
49	2	Terminal Bracket					
50	1	Lock Washer					
51	1	Limit Switch Bracket	Steel				
52	1	O-Ring	Buna				
53	4	Screw					
54	4	Lock Washer					
55	1	Capacitor					
56	1	Handwheel	Aluminium				
57	1	O-ring	Buna				
58	1	Washer					
59	1	Spring					
60	1	Handwheel Cover					
61	1	Clutch Ring	Steel				
62	1	O-Ring	Buna				
63	1	Handwheel Bearing	Bronze				
64	2	Worm Bearing	Bronze				
65	2	Thrust Bearing	Steel				
66	1	Wormwheel	Bronze				



PC.NO.	QTY.	DESCRIPTION.	MATERIAL.	PC.NO.	QTY.	DESCRIPTION.	MATERIAL.
1	1	Motor		65	1	Screw	
2	5	Screw		66	1	Key	
3	1	Housing	Aluminium	67	16	Torque Spring	
4	1	Motor Support Plate	Steel	68	1	Worm	Steel
5	1	T.Sw. Spacer	Steel	69	1	Worm Shaft	Steel
6	8	Lock Washer		70	1	Ball	Steel
7	1	Hexnut	Steel	71	1	key	
8	2	Screw		72	1	Worm Cap	Aluminium
9	3	Nut		73	1	O-Ring	Buna
10	4	Screw	Steel	74	1	Screw	
11	13	Lock Washer		75	2	Nut	
12	1	Torque Switch Collar	Aluminium	76 a	1	Drive Sleeve (EL-200)	Cast iron
13	1	Torque Switch Bracket	Steel	76 b	1	Drive Sleeve (EL-350)	Bronze
14	1	Torque Switch Bearing	Brass	77	2	Screw	
15	1	Dowel Pin		78	2	Window gasket	
16	6	Micro Switch		79	2	Dowel Pin	
17	2	Torque Switch Spacer		80	1	Bearing	Bronze
18	2	Screw		81	1	Worm Shaft Gear	Steel
19	2	Screw	Steel	82	1	Pin Spiral	Steel
20	1	Drive Sleeve Bearing	Steel	83	1	Worm	Steel
21	1	O-Ring	Buna	84	1	Pin Spiral	Steel
22	1	Pin Spiral	Steel	85	1	Worm Shaft	Steel
23	1	Top Spring		86	2	Thrust Bearing	Steel
24	1	Top Bearing	Steel	87	1	Bearing	Bronze
25	1	O-Ring	Buna	88	1	Motor Pinion	Steel
26	9	Insulation plate		89	1	Pin Spiral	
27	2	Screw		90	1	Window Sticker	
28	1	Motor Gasket		92	1	Sticker Open/Closed	
29	2	Limit Switch cam	Aluminium	93	3	Blindstop	
30	4	Screw		94	1	Washer	Steel
31	1	Indicator Shaft	Steel	95	2	Screw	
32	1	Dial		96	4	Screw	
33	1	Gasket T.S.		98	1	Screw	Steel
34	1	Screw		99	1	Screw	
35	1	Window	Lexan	100	3	Screw	
36	1	Cover	Steel	101	1	Window holder	Steel
37	1	Heater		102	1	Topbearing gasket	
38	3	Screw		103	7	Toothwasher	
39	6	Screw		104	1	Motor support plate gasket	
40	1	Screw	Steel	119	1	Limitswitch Cam Green	Aluminium
41	1	Handwheel gasket		120	1	Limitswitch Cam Red	Aluminium
42	1	Heater Bracket	Steel	125	1	Support Plate Switch	Steel
43	2	Terminal Block					
44	2	Marking Tag					
45	2	Terminal Sticker					
46	4	Screw					
47	2	Terminal Bracket	Steel				
48	6	Screw					
49	1	Limit Switch Bracket	Steel				
50	1	O-Ring	Buna				
51	4	Screw					
52	4	Lock Washer					
53	1	Capacitor					
54	1	Handwheel	Aluminium				
55	2	O-Ring	Buna				
56	4	Washer					
57	1	Handwheel Spring	steel				
58	1	Handwheel Cover					
59	1	Pin Spiral					
60	1	O-Ring	Buna				
61	1	Handwheel Bearing	Bronze				
62	2	Worm Bearing	Bronze				
63	2	Thrust Bearing	Steel				
64	1	Worm Wheel	Bronze				

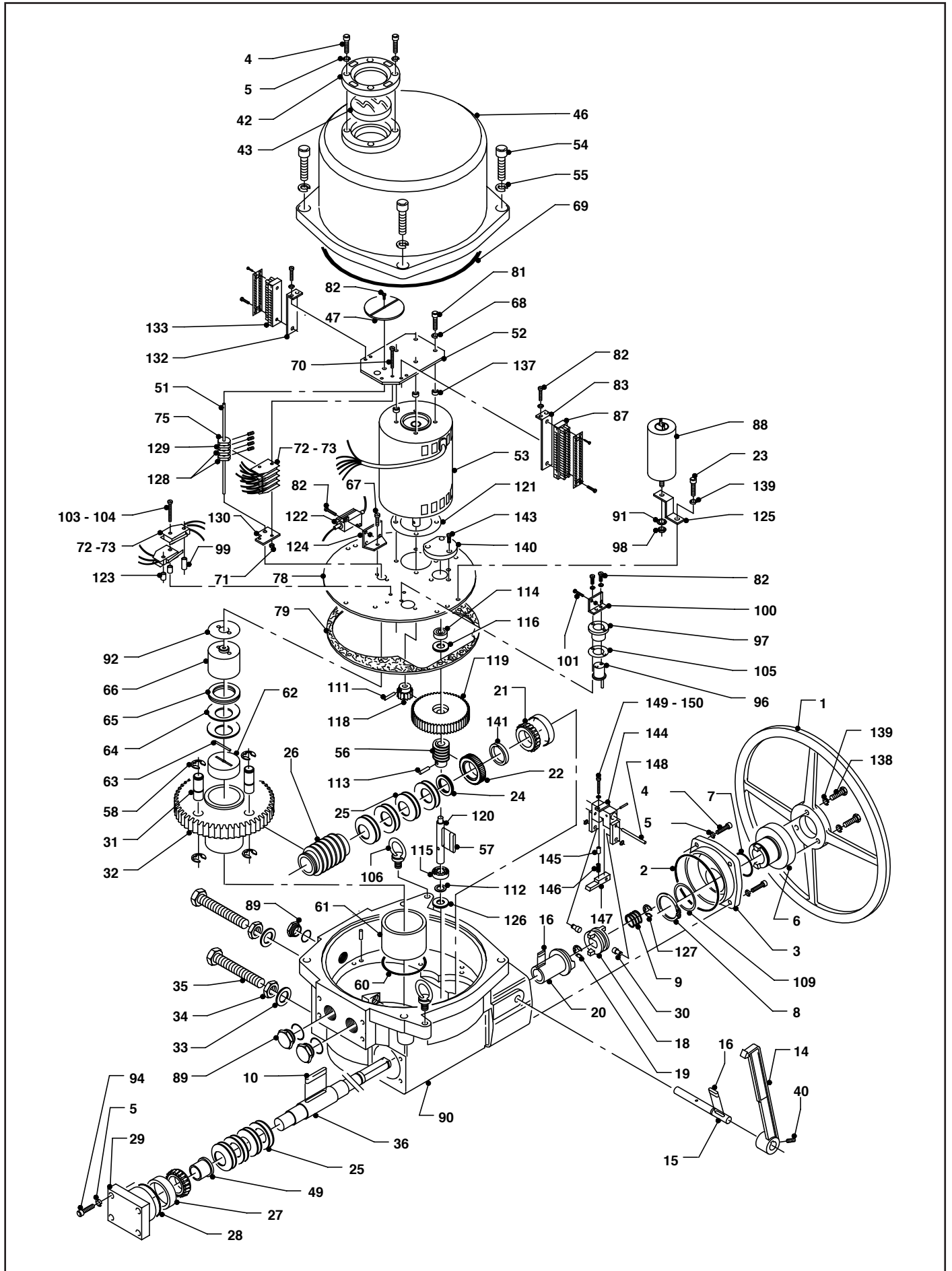


# EL-500/800

# Parts and Materials

PC.NO.	QTY.	DESCRIPTION.	MATERIAL.	PC.NO.	QTY.	DESCRIPTION.	MATERIAL.
1	1	Housing	Aluminium	64	2	Limitswitch Cam	Aluminium
2 a	1	Drive Sleeve (EL-500)	Cast iron	65	1	Limitswitch Cam Green	Aluminium
2 b	1	Drive Sleeve (EL-800)	Bronze	66	1	Window	Lexan
3	1	Handwheel	Aluminium	67	2	Window Sticker	
4	1	Pin		69	1	Indicator Shaft	Steel
5	2	Washer		70	1	Limit Switch Cam Red	Aluminium
6	1	Spring		71	4	Screw	
7	1	Handwheel Cover		72	6	Micro Switch	
8	1	Sticker Open/Close		73	3	Screw	
9	1	Bearing	Bronze	74	9	Insulation plate	
10	2	Thrust Bearing	Steel	75	2	Screw	
11	1	Worm		76	1	Handwheel gasket	
12	1	Pin		77	1	Cover	Steel
13	1	Worm Shaft Gear	Delrin	78	1	O-Ring	Buna
14	1	Pin		79	1	Torque Switch spacer	
15	1	Bearing	Bronze	80	2	Screw	
16	14	Lock Washer		81	9	Nut	
17	4	Screw	Steel	83	2	Torque Switch Spacer	
18	1	O-Ring	Buna	84	2	Screw	
19	1	O-Ring	Buna	85	1	Torque Switch Collar	Aluminium
20	1	Handwheel Bearing	Brass	86	1	Torque Switch Bearing	Brass
21	1	Worm Shaft	Steel	87	1	Torque Switch Bracket	Steel
22	1	Motor Pinion	Delrin	88	1	Dowel Pin	
23	2	Worm Shaft Bearing	Bronze	90	1	Drive Sleeve Bearing	Steel
24	2	Thrust Bearing	Steel	91	1	O-Ring	Buna
25	1	Worm Wheel	Bronze	92	1	Pin Spiral	Steel
26	1	Key		93	2	Drive Sleeve Spring	Steel
27a	16	Torque Spring (EL 500)	Steel	94	1	Thrust Bearing	Steel
27b	24	Torque Spring (EL 800)	Steel	95	1	Top Bearing	Steel
28	2	Dowel Pin		96	1	Worm Shaft	Steel
29	1	Key		97	1	O-Ring	Buna
30	1	Worm	Steel	98	1	Motor	
31	1	WormCap	Aluminium	99	2	Screw	
32	1	Ball	Steel	100	1*	Capacitor	
33	15	Lock Washer		103	1	Pin	
34	4	Screw		104	1	Screw	
35	1	Screw		105	1	Window holder	Steel
36	1	Screw		106	7	Tooth Washer	
37	1	O-Ring	Buna	107	1	Motor support plate gasket	
38	2	Screw		108	2	Window gasket	Rubber
39	2	Screw		109	1	Motor gasket	
40	2	Nut		110	1	Topbearing gasket	
41	2	Washer		111	1	Toothwasher	
42	1	Limit Switch Bracket	Steel	112	1	Hex nut	
43	4	Lock Washer		120	1	Washer	Steel
44	4	Screw		121	1	Nut	Steel
45	1	Heater		122	1	Torque Switch Gasket	
46	8	Screw	Steel	123	1	Support Plate Switch	Steel
47	2	Screw					
48	1	Bung Drive Sleeve	Steel				
49	1	Dowel Pin	Steel				
50	1	Heater Bracket	Steel				
51	2	Terminal Block					
52	2	Marking Tag					
53	2	Terminal Sticker					
54	4	Screw					
55	2	Terminal Bracket	Steel				
56	8	Screw					
57	4	Screw					
58	4	Lock Washer					
60	3	Blindstop					
61	1	Motor Support Plate	Steel				
62	7	Screw					
63	1	Dial					

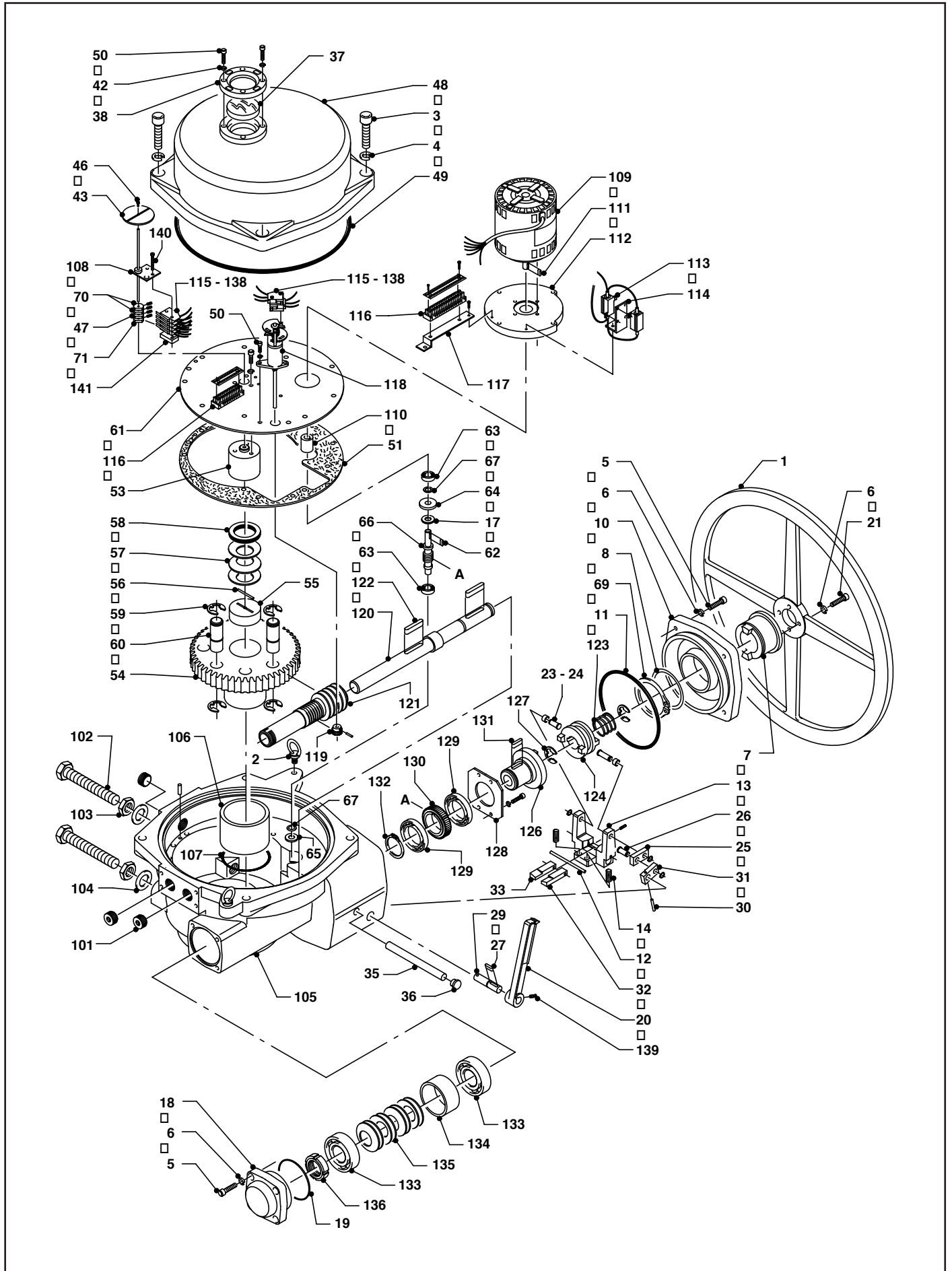
\* Capacitor quantity varies with size and voltage



# EL-1200/1600

# Parts and Materials

PC.NO.	QTY.	DESCRIPTION.	MATERIAL.	PC.NO.	QTY.	DESCRIPTION.	MATERIAL.
1	1	Handwheel	Aluminium	79	1	Gasket Motor Support Plate	
2	1	O-Ring	Buna	81	4	Screw	Steel
3	1	Handwheel Cap	Aluminium	82	13	Screw	Steel
4	7	Screw	Steel	83	1	Terminal Bracket	Steel
5	12	Lockwasher	Steel		4	Screw	Steel
6	1	H.W. Adaptor	Aluminium	87	1	Terminal Block	
7	1	O-Ring	Buna	88	1	Capacitor	
8	1	Retaining Ring	Steel	89	3	Blindplug	
9	1	Spring	Steel	90	1	Housing	Aluminium
10	3	Key	Steel	91	1	Toothwasher	Steel
15	1	Declutch Shaft	Steel	92	1	Gasket Top Bearing	
16	2	Key	Steel	94	4	Screw	Steel
18	1	Clutch	Steel	96	1	T.S. Collar	Aluminium
19	1	Retaining Ring	Steel	97	1	T.S. Bush Bearing	Bronze
20	1	Worm Gear Sleeve	Steel	98	1	Hex Nut	Steel
21	1	Bearing	Steel	99	1	Spacer	Steel
22	1	Wormwheel	Bronze	100	1	T.S. Bracket	Steel
23	7	Screw	Steel	101	2	Screw	Steel
24	1	Bearing	Steel	103	2	Screw	Steel
25	16	Spring EL1200	Steel	104	1	Screw	Steel
25a	16	Spring EL1600	Steel	105	1	Gasket Torque Switch	
26	1	Worm EL1200	Steel	106	2	Lifting Bolt	Steel
26a	1	Worm EL1600	Steel	109	1	Shim Ring	Steel
27	1	Bearing	Steel	111	1	Pin	Steel
28	1	O-Ring	Buna	112	1	Shim Ring	Steel
29	1	Endcap	Aluminium	113	1	Pin	Steel
30	2	Declutch Rivet	Steel	114	1	Ball Bearing	
31	2	Pin	Steel	115	1	Ball Bearing	
32	1	Drive Sleeve EL1200	Cast Iron	116	1	Thrust Bearing	
32a	1	Drive Sleeve EL1600	Bronze	118	1	Motor Pinion	Steel
33	2	Washer	Steel	119	1	Worm Shaft Gear	Steel
34	2	Hex nut	Steel	120	1	Worm Shaft	Steel
35	2	Screw	Steel	121	1	Gasket Motor	
36	1	Wormshaft	Steel	122	1	Heater	
40	1	Screw	Steel	123	2	T.S. Spacer	Steel
42	1	Window Holder	Steel	124	1	Heater Bracket	Steel
43	1	Window	Glass	125	1	Capacitor Bracket	Steel
46	1	Cover	Aluminium	126	1	Thrust Bearing	Steel
47	1	Dial	Steel	127	1	Retaining Ring	Steel
49	1	Bearing	Bronze	128	2	Limitswitch Cam	Aluminium
51	1	Indicator Shaft	Steel	129	1	Limitswitch Cam	Aluminium
52	1	Limitswitch Bracket	Steel	130	1	Support Plate Limitswitch	Steel
53	1	Motor		132	1	Terminal Bracket	Steel
54	4	Screw	Steel	137	4	Spacer	Steel
55	4	Lockwasher	Steel	138	3	Screw	Steel
56	1	Worm	Steel	139	10	Lockwasher	Steel
57	1	Key	Steel	140	1	Bearing Cap	Steel
58	4	Retaining Ring	Steel	141	1	Wormwheel Ring	Bronze
60	1	O-Ring	Buna	143	3	Screw	Steel
61	1	Bearing	Steel	144	1	Declutch Fork	Steel
62	1	Bung D.S.	Steel	145	1	Spring Declutch	Steel
63	1	Pin	Steel	146	1	Spacer	Steel
64	2	Spring	Steel	147	1	Latch	Steel
65	1	Bearing	Steel	148	1	Latch screw	Steel
66	1	Top Bearing	Steel	149	1	Screw	Steel
67	2	Screw	Steel	150	1	Lockwasher	Steel
68	6	Lockwasher	Steel				
69	1	O-Ring	Buna				
70	2	Screws	Steel				
71	6	Hex Nut + Lockwasher	Steel				
72	7	Isolation Plate					
73	6	Microswitch					
75	1	Limitswitch Cam	Aluminium				
78	1	Motor Support Plate	Steel				



PC.NO.	QTY.	DESCRIPTION.	MATERIAL.	PC.NO.	QTY.	DESCRIPTION.	MATERIAL.
1	1	Handwheel	Aluminium	105	1	Housing	Aluminium
2	2	Lifting Bolt	Steel	106	1	Bearing	
3	4	Screw	Steel	107	1	O-Ring	Buna
4	4	Lockwasher	Steel	108	1	Support Plate Limitswitch	Steel
5	8	Screw	Steel	109	1	Motor	
6	12	Lockwasher	Steel	110	1	Motor Bushing	Steel
7	1	Handwheel Adaptor	Aluminium	111	1	Key	Steel
8	1	O-Ring	Buna	112	1	Adaptor	Steel
10	1	Handwheel Cap	Aluminium	113	2	Heater	
11	1	O-Ring	Buna	114	1	Heater Bracket	Steel
12	1	Latch Shaft	Steel	115	6	Micro Switch	
13	1	Declutch Fork	Steel	116	2	Terminal Block	
14	2	Spring Declutch	Steel	117	1	Terminal Bracket	Steel
17	4	Plain Bearing		118	1	Torque Switch Compleet	
18	1	Spring Pack Cover	Aluminium	119	1	T.S. Pinion + Rol Pin	
19	1	O-Ring	Buna	120	1	Wormshaft	Steel
20	1	Declutch Lever	Aluminium	121	1	Wormshaft Bush	Steel
21	4	Screw	Steel	122	2	Key	Steel
23	2	Declutch Rivet	Steel	123	1	Spring	Steel
24	3	Retaining Ring	Steel	124	1	Clutch	Steel
25	1	Declutch Link	Steel	126	1	Worm Gear Sleeve	Steel
26	2	Declutch Rivet	Steel	127	2	Retaining Ring	Steel
27	1	Key	Steel	128	1	Bearing Plate	Steel
29	1	Shaft Declutch Lever	Steel		4	Screw + Washer	Steel
	1	O-Ring Shaft Decl.	Buna	129	2	Ball Bearing	
30	1	Pin Declutch Lever	Steel	130	1	Wormwheel	Bronze
31	1	Declutch Link	Steel	131	1	Key	Steel
32	1	Latch Left	Steel	132	1	Retaining Ring	Steel
33	1	Latch Right	Steel	133	2	Bearing	Steel
35	1	Declutch Shaft	Steel	134	1	Torque Limiter Sleeve	Steel
36	2	Cover Plug		135	8	Spring	Steel
37	1	Window	Glass	136	1	Lock Nut	Steel
38	1	Window Holder	Steel	138	8	Isolation Plate	
42	2	Screw	Steel	139	1	Screw	Steel
43	1	Dial	Steel	140	2	Threaded Rod	Bronze
46	1	Screw + Washer	Steel	141	1	Spacer	Aluminium
47	1	Limitswitch Cam	Aluminium				
48	1	Cover	Aluminium				
49	1	O-Ring	Buna				
50	15	Screw	Steel				
51	1	Gasket					
	1	Indicator Shaft	Steel				
53	1	Top Bearing	Steel				
54	1	Drive Sleeve	Bronze				
55	1	Bung Drive Sleeve	Steel				
56	1	Pin	Steel				
57	3	Spring	Steel				
58	2	Bearing					
59	4	Retaining Ring	Steel				
60	2	Stop Pin	Steel				
61	1	Motor Support Plate	Steel				
62	1	Key	Steel				
63	2	Bearing					
64	1	Plain Washer	Steel				
65	1	Bearing					
66	1	Wormshaft	Steel				
67	2	Shim Ring	Steel				
69	1	Retaining Ring + Shim Ring					
70	2	Limitswitch Cam	Aluminium				
71	1	Limitswitch Cam	Aluminium				
101	3	Blindplug	Steel				
102	2	Screw	Steel				
103	2	Hex Nut	Steel				
104	2	Washer	Steel				

# Mechanical Limit stop - Setting

---

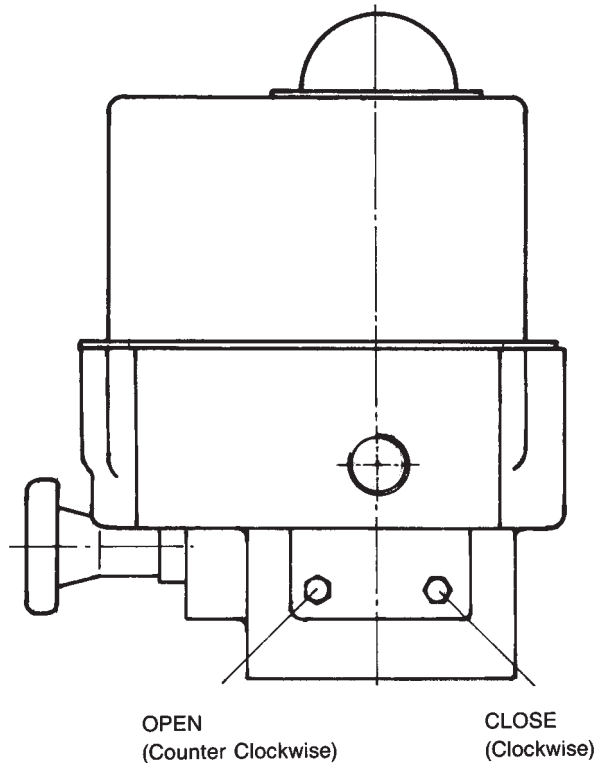


fig. 2a.

## Location of Limit Stops

All EI-series electric actuators are equipped with a manual override feature and a Stroke Adjustment System. The purpose of this system is to limit the stroke of the valve while under manual control.

On torque switch equipped actuators the limit stops may be used to provide a greater degree of stroke precision than by limit switches. ie. for high performance butterfly valves.

After the actuator has been fitted on a valve and the end of travel limit switches have been set, the mechanical stops can be set as follows:

Before beginning please note:

### Important.

- ◆◆ For torque seated applications the mechanical stops do not need setting in the positions that torque seating is required and the stop screws should be backed off approx. 2 turns from the fully closed or open position. This to prevent the torque switch from tripping on the stop screws and not on the valve seat.

## Procedure

1. With actuator mounted to a valve, electrically or manually move the valve away from the fully open position.
2. Turn the open stop screw out (ccw) 4 turns.
3. Manually operate the actuator to the full open position.
4. Now turn the open stop screw in (cw) until an obstruction is felt (do not force) then backoff 1/2 turn and lock the stop screw with the locknut.
5. Follow the same procedure at the closed end of travel and adjust the "close" stop screw the same way.

# Limit Switch Setting

Set mechanical stops before setting limit switches. The end of travel limit switches have been factory set for approximately 90° of valve travel. They will however coincide with the exact end of valve travel positions.

The switches should be adjusted after the actuator is installed on the valve and after the mechanical stops have been set.

The switches and their operating cams are located under the limit switch bracket which is fixed to the top of the motor.

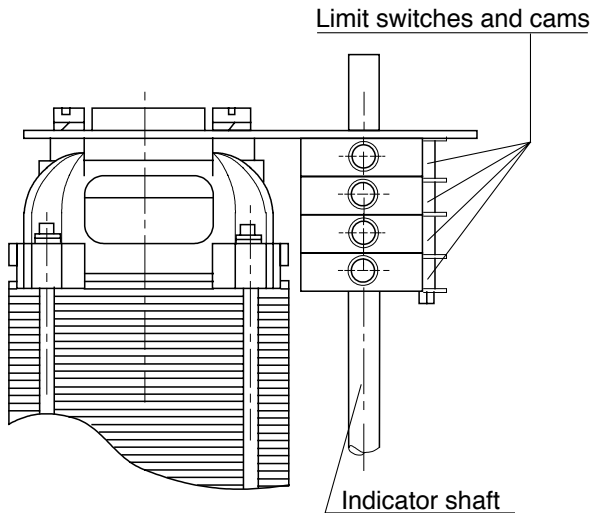


fig. 1a. Location of Limit Switches

Before beginning please note:

### Important

- ◆◆ The motor is de-energized once the flatted side of the cam is in contact with the limit switch actuator arm, and the switch is no longer depressed.

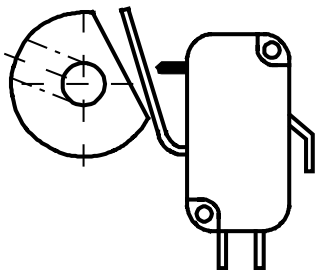


fig. 1b. Switch Break Position

### Also

- ◆◆ Capacitor may be removed from the limit switch bracket for better access.
- ◆◆ For more precise setting you can leave the allen wrench in the cam during setting procedure.

### Procedure

1. Remove actuator cover.
2. The limit switches are marked "1" for close and "2" for open.

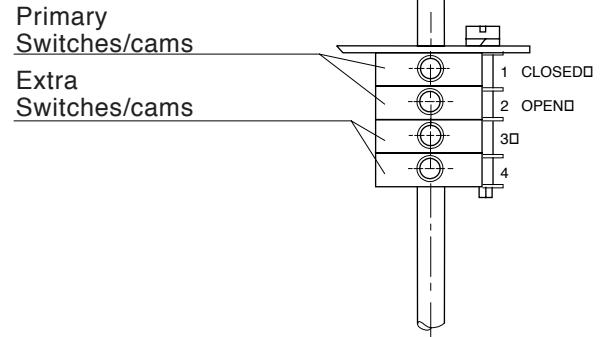


fig. 1c. Switch Functions.

### CCW (Open) switch setting

3. Manually or electrically rotate actuator/valve to the desired position.
4. **REMOVE ELECTRICAL POWER.**
5. Using a 2mm allen wrench loosen set screw on cam.
6. Rotate green cam until switch lever arm rides on the curved portion of the cam. (fig 1d).

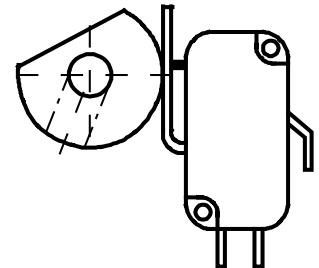


fig. 1d. Initial Position

7. Rotate cam counter-clockwise until the switch trips. This can be detected by a slight audible "click", or use a battery powered test light across terminal 8 and 10.
8. Tighten set screws.
9. Electrically cycle the actuator to check switch setting.

### CW (Close) limit switch setting

10. Manually or electrically rotate actuator/valve to the desired position.
11. **REMOVE ELECTRICAL POWER.**
12. Using a 2mm allen wrench loosen set screw on cam.
13. Rotate red cam until switch lever arm rides on the curved portion of the cam (fig 1d).
14. Rotate cam clockwise until the switch trips. This can be detected by a slight audible "click", or use a battery powered test light across terminal 5 and 7.
15. Tighten set screws.
16. Electrically cycle the actuator to check switch settings.

# Potentiometer - Installation Instructions

- POT

The potentiometer itself is fixed on the limit switch bracket and is driven by a pair of gears from the indicator shaft.

**Before starting check "POT" kit to ensure that all parts are available.  
Always verify if potentiometer value suits your requirement prior to mounting in actuator.**

Pc.Nr.	Qty	Description
3	1	Drive pinion (large).
4	1	Potentiometer pinion (small).
5	1	Potentiometer spacer.
6	1	Potentiometer.

3. Mount potentiometer (6) on limit switch bracket using nut and spacer (5).
4. Slide potentiometer pinion (4) (small) onto pot. shaft and tighten screw.
5. Slide drive pinion (3) (large) over indicator shaft.
6. Ensure that end of travel limit switches have been set correctly and actuator is in mid position. Turn potentiometer shaft in mid position and tighten drive pinion screw onto the indicator shaft (do not overtighten).

## Procedure

1. Remove actuator cover (1).
2. Remove dial (2).

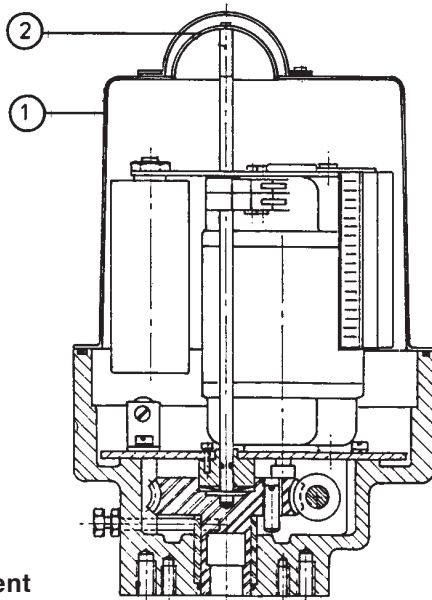


Fig. 1. General Arrangement

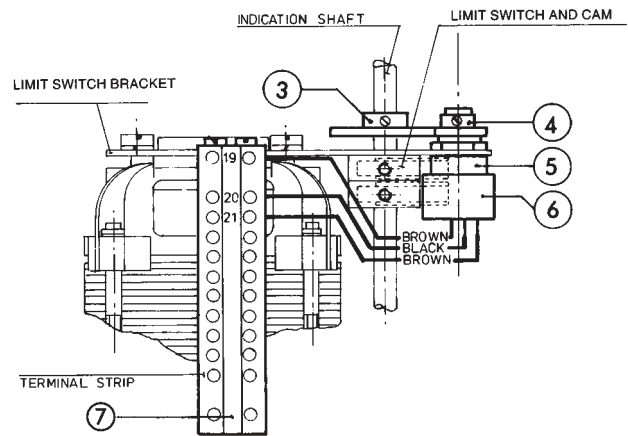


Fig. 2. Potentiometer detail

7. Replace dial (1) and align in the proper position. Replace actuator cover and fasten bolts securely taking care that the "O" ring is properly located in the "O" ring groove.

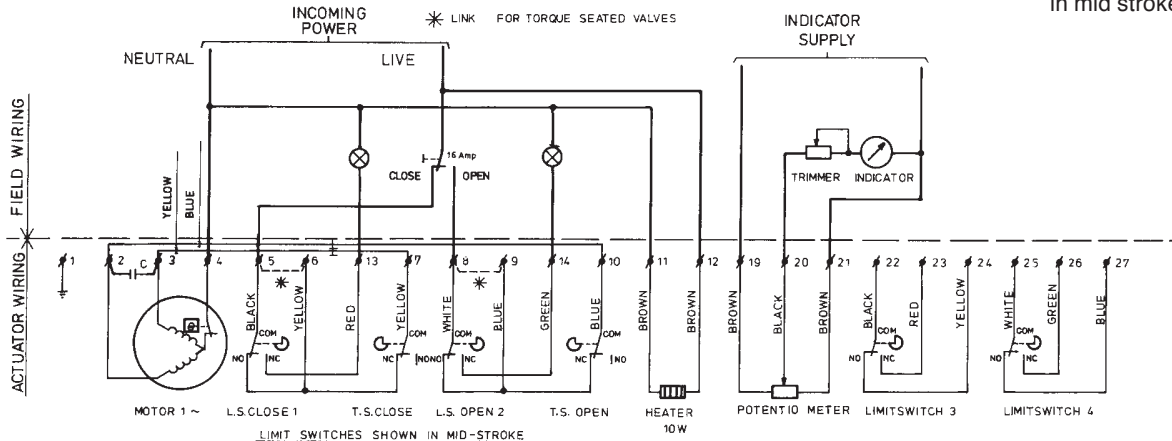
## EL100-114

### IMPORTANT

Each actuator must be powered through its own individual switch or relay contacts to avoid cross feed between two or more actuators.

### MOTOR WIRING

EL 100/ 150 2=BLUE 3=BLACK 4=BROWN EL 200 / EL1200 2=BLACK 3=BLUE 4=BROWN



EL 100-1600 shown, EL 55 is the same except that it has no torque switches. Limit switches are shown in mid stroke.

Dec.'96

# Speed controller - Installation Instructions

- SC/ESC

The speed controller board is fixed on the limit switch bracket on top of the motor.

**Before starting check the kit to ensure that all parts are available and the speed controller card voltage is the same as the actuator voltage.**

There are two versions : 110 - 250V AC  
: 24V DC

Pc.Nr.	Qty	Description	Used on
9	3	Print spacer	EL 55
9	3	Spacer	EL 100 -1600
10	1	Speed controller board	EL 55 -1600

## Procedure

1. Remove actuator cover (1).
2. Remove dial (2).

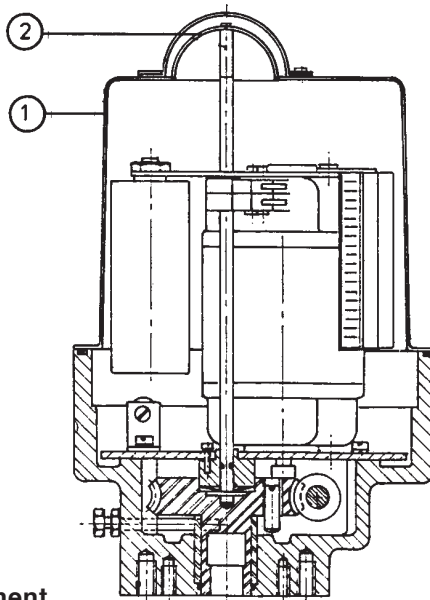


Fig. 1. General Arrangement

- 3a. For EL 55.  
Insert three spacers (9) into the limit switch bracket and place speed control board so that the spacers locate correctly in the three holes in the circuit board. Press firmly into place.
- 3b. For EL 100 through 800 only.  
Mount speed control board on limit switch bracket using 3 screws and 3 plastic spacers (the screws engage with 3 nuts welded to top motor plate).

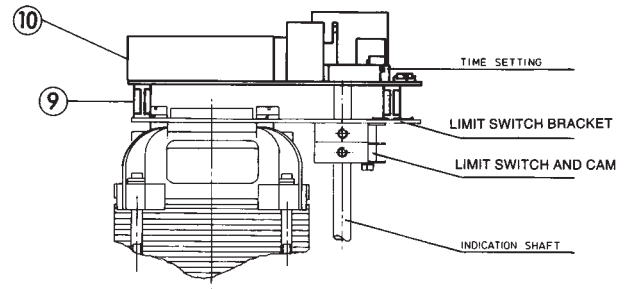
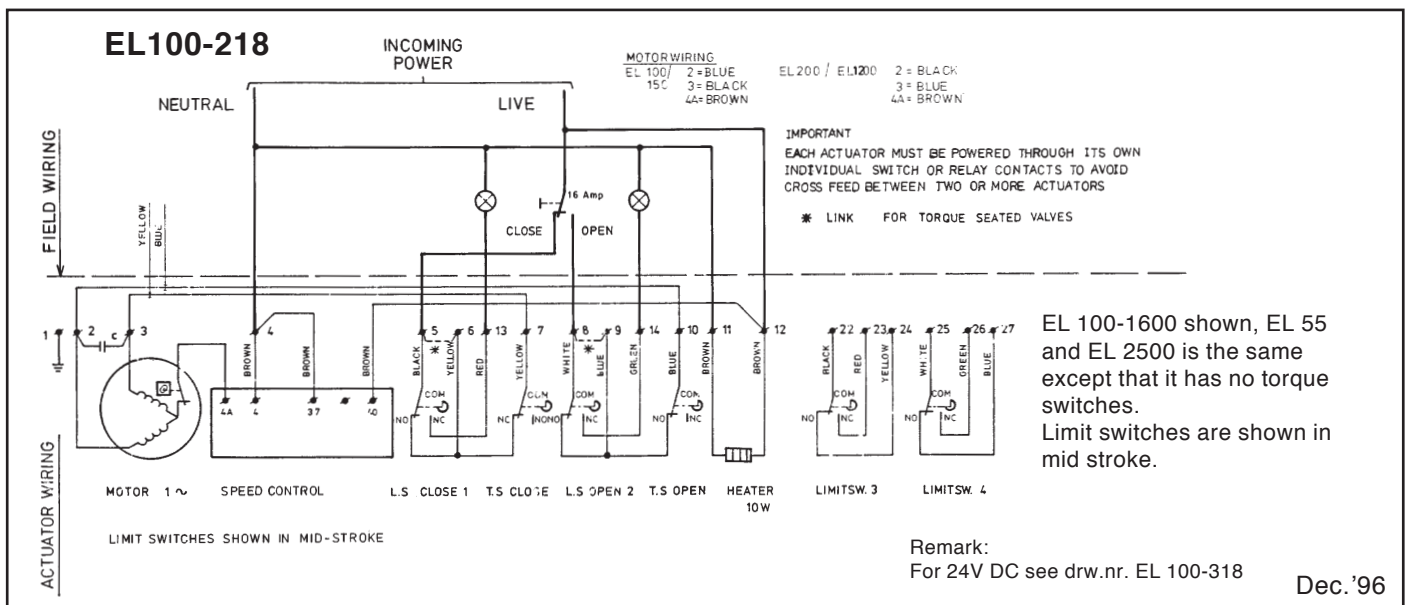


Fig. 2. Speed controller detail

4. Connect speed control terminal 40 (brown) to terminal 12.
5. Remove violet motor lead from terminal 4 and crimp to the violet wire connected to terminal 4a on the speed control board. Then connect the violet wire connected to terminal 4 on the speed control board to terminal 4 on the main actuator terminal strip.
6. Connect power supply to the actuator. This must be the correct voltage as shown on the actuator name plate.
7. Pre-set pot "Speed Adjustment Control" fully CW (fastest) and operate actuator to verify correct operation. "Speed Adjustment Control" may now be adjusted CCW to achieve desired operating time.
8. Replace dial (1). Replace actuator cover and fasten bolts securely taking care that the "O" ring is properly located in the "O" ring groove.



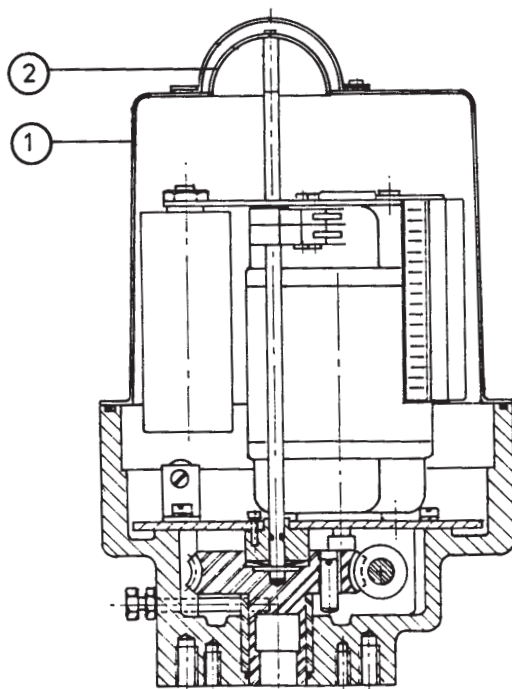
The position transmitter card is fixed on top of the limit switch bracket with the potentiometer fixed to the bracket itself, the drive for this is by a pair of gears from the indicator shaft.

**Before starting check "PT2" kit to ensure that all parts are available.**

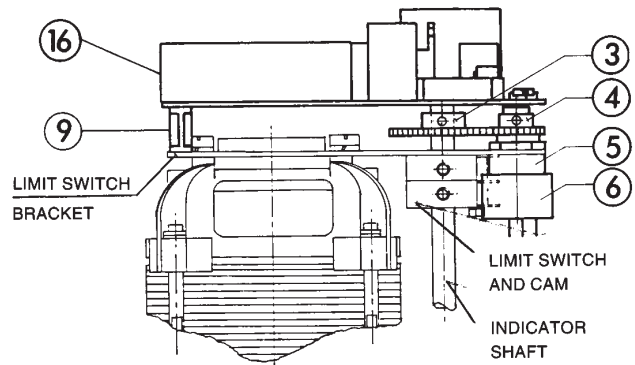
Pc.Nr.	Qty	Description	Used on
3	1	Drive pinion (large).	EL 55 - EL 2500
4	1	Pinion (small).	EL 55 - EL 2500
5	1	Potentiometer spacer.	EL 55 - EL 2500
6	1	Potentiometer	EL 55 - EL 2500
9	3	Print spacer	EL 55 - EL 2500
9	3	Print spacer and screw	EL 100 - EL 1600
16	1	Position transmittercard	EL 55 - EL 2500

## Installation Procedure

1. Remove actuator cover (1).
2. Remove dial (2).



**Fig. 1.**  
**General Arrangement**



**Fig. 2. Position Transmitter Detail**

3. Mount potentiometer (6) on limit switch bracket using nut and spacer (5).
4. Slide potentiometer pinion (4) (small) onto pot. shaft and tighten screw. (Do not overtighten)
5. Slide drive pinion (3) (large) onto indicator shaft.
6. Ensure that end of travel limit switches have been set correctly and actuator is in mid position. Turn potentiometer shaft in mid position and tighten drive pinion screw onto the indicator shaft (do not overtighten).
- 7a. For EL-55.  
Insert three spacers (9) into limit switch bracket and place position transmitter board so that the spacers locate correctly in the three holes in the circuit board. Press firmly into place.
- 7b. For EL-100 through EL-1600.  
Mount position transmitter on limit switch bracket using 3 screws (9) and 3 plastic spacers (the screws engage with 3 nuts welded to top motor plate).
- 7c. For EL-2500.  
Insert three spacers (9) into print bracket and place position transmitter board so that the spacers locate correctly in the three holes in the circuit board. Press firmly into place.

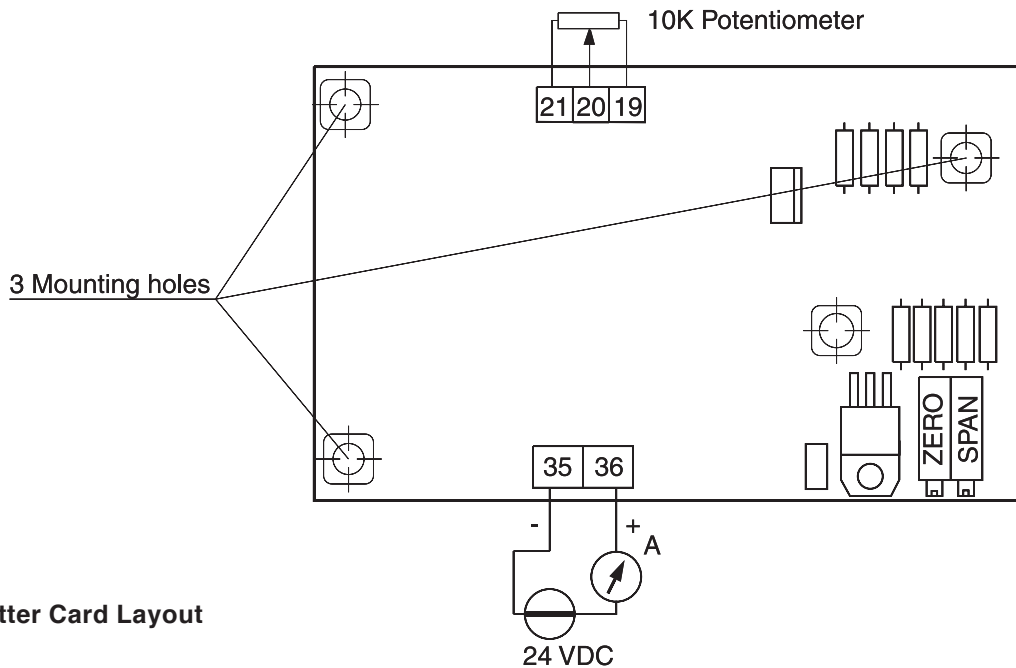


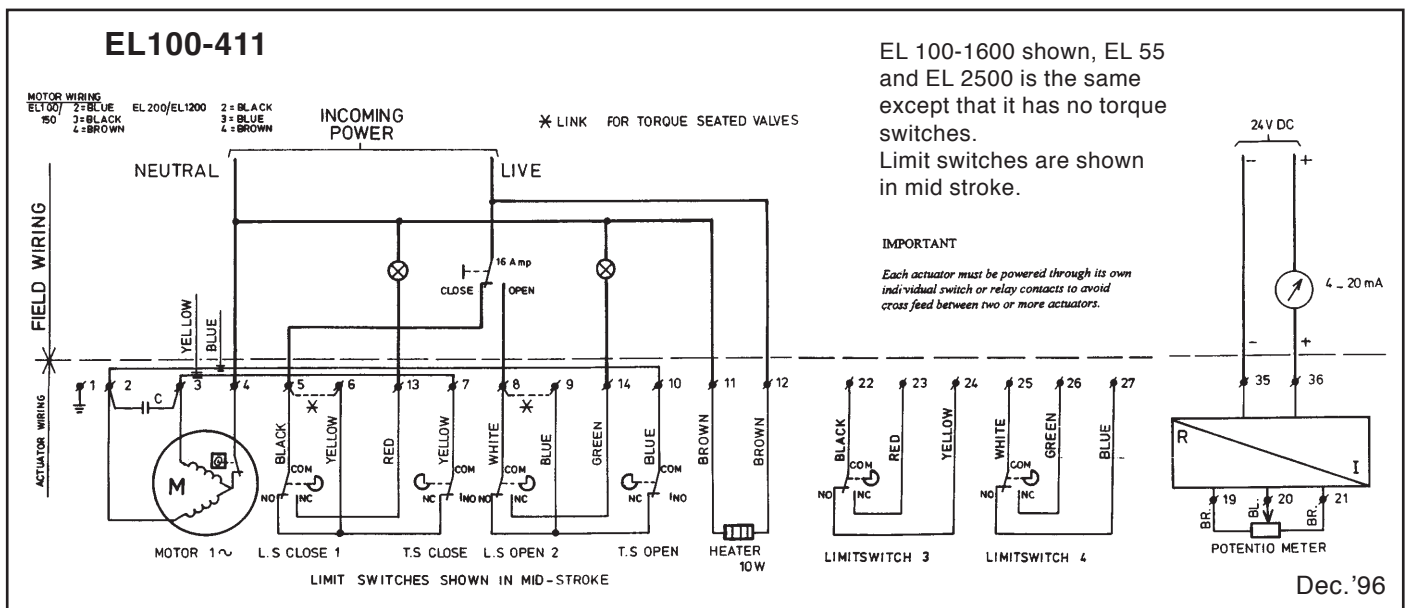
Fig. 3. Position Transmitter Card Layout

Calibration Procedure

8. Connect 24 V DC. power supply to terminals 35 and 36, positive lead to be connected to terminal 36. Connect a 4 - 20 mA meter in series with positive power supply and terminal 36. As shown in the wiring diagram below.
9. Turn actuator to the fully closed position and install 24 V.DC. power supply to position transmitter and check if mA meter indicates approximately 4 mA. If meter indicates approx 20 mA, reverse brown potmeter leads at terminals 19 and 21, meter should now indicate 4 mA.
10. Adjust trimpotmeter marked "ZERO" to achieve 4 mA. then operate actuator to the fully open position and adjust trim potmeter marked "SPAN" to achieve 20 mA. (This step may have to be repeated several times to achieve accurate indication).
11. Replace dial (1) and align in the proper position. Replace actuator cover and fasten bolts securely taking care that the "O" ring is properly located in the "O" ring groove

Note: EL55 does not have torque switches.

Note: A digital mA meter may be connected in series with power supply for a more accurate setting.

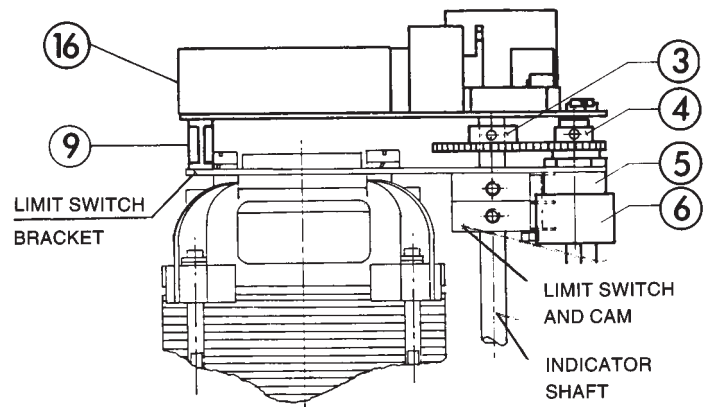


Dec.'96

The position transmitter card is fixed on top of the limit switch bracket with the potentiometer fixed to the bracket itself, the drive for this is by a pair of gears from the indicator shaft.

Before starting check "PT4" kit to ensure that all parts are available.

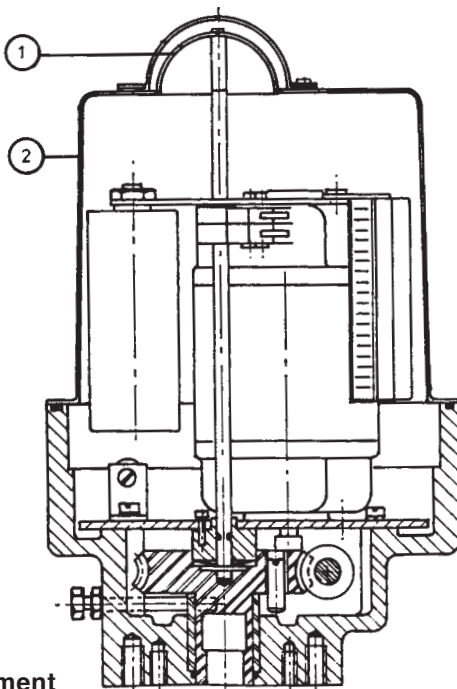
Pc.Nr.	Qty	Description	Used on
3	1	Drive pinion (large).	EL 55 - EL 2500
4	1	Pinion (small).	EL 55 - EL 2500
5	1	Potentiometer spacer.	EL 55 - EL 2500
6	1	Potentiometer	EL 55 - EL 2500
9	3	Print spacer	EL 55 - EL 2500
9	3	Print spacer and screw	EL 100 - EL 1600
16	1	Position transmittercard	EL 55 - EL 2500



**Fig. 2. Position Transmitter Detail**

## Installation Procedure

1. Remove actuator cover (2).
2. Remove dial (1).



**Fig. 1. General Arrangement**

3. Mount potentiometer (6) on limit switch bracket using nut and spacer 5.
4. Slide potentiometer pinion (4) (small) onto pot. shaft and tighten screw.
5. Slide drive pinion (3) (large) onto indicator shaft.
6. Ensure that end of travel limit switches have been set correctly and actuator is in mid position. Turn potentiometer shaft in mid position and tighten drive pinion screw onto the indicator shaft (do not overtighten).
- 7a. For EL-55.  
Insert three spacers (9) into limit switch bracket and place position transmitter board so that the spacers locate correctly in the three holes in the circuit board. Press firmly into place.
- 7b. For EL-100 through 1600.  
Mount position transmitter on limit switch bracket using 3 screws and 3 plastic spacers (the screws engage with 3 nuts welded to limit switch bracket).
- 7c. For EL-2500.  
Insert three spacers (9) into print bracket and place position transmitter board so that the spacers locate correctly in the three holes in the circuit board. Press firmly into place.

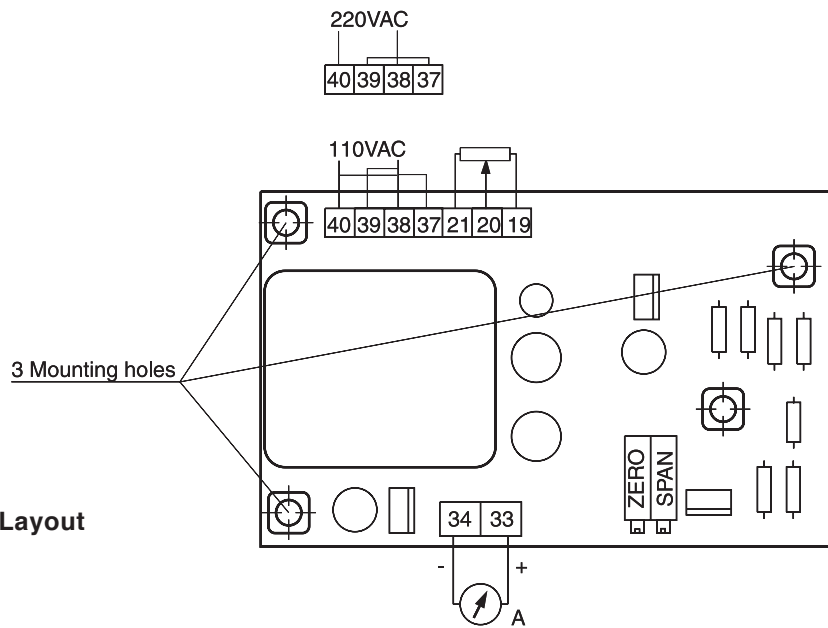


Fig. 3. Position Transmitter Card Layout

Calibration Procedure

8. Important:

**220 Volt:** Connect power supply leads to terminals 38 and 40, and place a link between terminals 37 - 39.

**120 Volt:** Connect power supply leads to terminals 38 and 40, place one link between terminals 37 - 40 and another between terminals 38 - 39.

9. Connect a 4 - 20 mA meter to terminals 33 and 34.

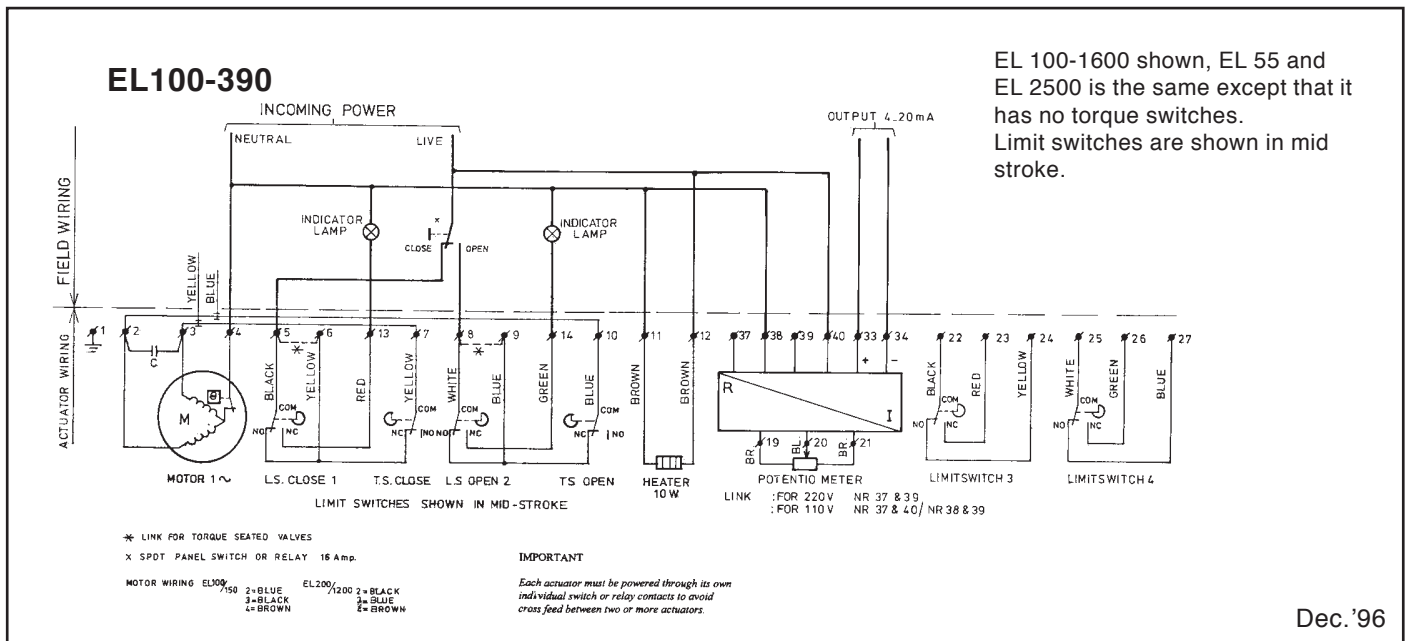
10. Apply power to the actuator and operate to the fully closed position, check if mA meter indicates approximately 4 mA. If meter indicates approx 20 mA, reverse brown potmeter leads at terminals 19 and 21, meter should now indicate 4 mA.

11. Adjust trimpotmeter marked "ZERO" to achieve 4 mA. Then operate actuator to the fully open position and adjust trimpotmeter marked "SPAN" to achieve 20 mA. (This step may have to be repeated several times to achieve accurate indication).

Note: A digital mA meter may be connected in series with a panel meter and one of the terminals 33 or 34, this will not affect final readout on panel meters.

12. Replace dial (1) and align in the proper position. Replace actuator cover and fasten bolts securely taking care that the "O" ring is properly located in the "O" ring groove.

Note: EL55 does not have torque switches.



## THEORY OF OPERATION:

This electric valve actuator option provides continuous proportional position modulation for process control applications. The positioner drives the actuator to an angle of rotation proportional to the level of a 4-20 mA DC process control signal (other input current and voltage ranges are available) applied to its input terminals. Comparator circuits in the positioner compare the control signal with a reference signal generated by a potentiometer coupled to the actuator output shaft. A difference between the control signal and reference signal energizes the drive motor in the appropriate direction to eliminate the difference (achieve a null). The actuator drives at full speed until the difference signal is approximately 5% of span. At that point, a slow-approach-to-setpoint pulsing circuit slows the motor to achieve accurate positioning without overshoot. The slow-approach feature, by eliminating actuator over-shoot and attendant hunting, reduces motor heating and the need for high-duty-cycle motor ratings for positioning applications.

Calibration controls on the circuit board include Zero, Span, Alignment (mid-position linearity) and Deadband. Deadband adjustment is provided to eliminate hunting caused by small, frequent changes in process value.

Opto-isolation provides a high degree of noise immunity, especially important in industrial plants with high levels of power line noise. Triac motor switching eliminates relay contacts and improves long term reliability. Zero-crossing triac drivers further improve reliability while eliminating line noise generation. Limit switches and torque switches control actuator travel through positioner low-level control circuitry, further enhancing long term reliability.

A Re-transmit output signal (of the same current or voltage range as the input signal) is provided for remote position indication, process control feedback or an other process element.

## PHYSICAL DESCRIPTION:

The positioner circuit board is mounted inside the actuator electric compartment cover, becoming an integral part of the actuator. The feedback pot (potentiometer) supplied with the positioner option is of the conductive plastic type, offering stepless resistance feedback. The pot is environmentally sealed for improved durability. The pot is driven through spur gears by the actuator indicator shaft at a reduction ratio (for a 90° actuator) to enhance resolution. The pot is rigidly mounted to the actuator limit switch bracket, which also supports the positioner board. Available in field-retrofit kit form, the circuit board is supplied with pot and connection wires already attached, requiring only physical mounting and wiring to the actuator main terminal strip and field wiring.

## INSTALLATION:

Before Beginning Positioner Installation:

1. Connect the actuator as without positioner and operate to check for normal operation.
2. Set limit switches per instruction elsewhere in this Actuator Installation and Operation Manual.
3. Set actuator to mid position.
4. Leave electrical compartment cover off.
5. Disconnect power.
6. Motor capacitor may be temporarily removed from limit switch bracket to provide more working space.
7. Review the entire installation procedure before beginning.
8. Check kit contents against items in Table 1 (below).

PARTS LIST: MOD INSTALLATION KIT				
Fig #	Qty	Description	Used on EL	
			55	100/1600
3	1	Drive pinion (large)	*	*
4	1	Potentiometer pinion (small)	*	*
5	1	Potentiometer spacer	*	*
6	1	Potentiometer 10K Ohms	*	*
9	3	Standoff	*	*
9	3	Spacer/screw/washer	*	*
16	1	Positioner board	*	*
	1	Set screw, drive pinion	*	*
	2	Pin terminal, blue	*	*
	3	Wire tie	*	*

Table 1

## Mounting:

Refer to Fig. 1 for the following steps (numbers in brackets are figure references):

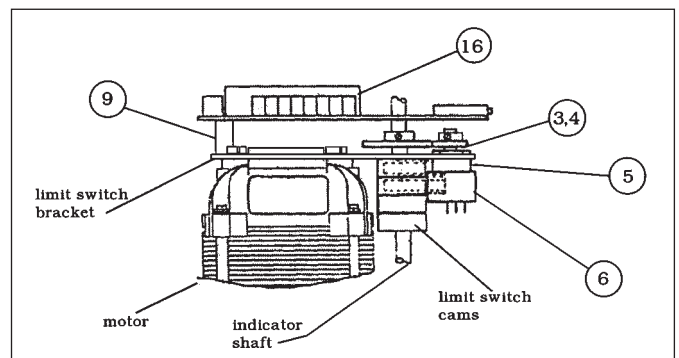


fig. 1. Positioner Mounting.

1. Remove position indicator dial.
2. **EL-55:** snap self-locking plastic spacers into three holes provided in limit switch bracket (position spacers with "wings" toward limit switch bracket).
3. Install setscrew in hub of large gear (potentiometer drive gear).
4. Install drive gear on indicator shaft (leave setscrew loose).

# Electronic Positioner - Installation and Calibration - MOD II

5. **EL-55:** slide positioner circuit board over indicator shaft and position on self-locking spacers but don't press board onto spacers at this time.  
**EL- 100 to 1600:** slide board over indicator shaft and rest on limit switch bracket in proper orientation.
6. Remove nut from pot bushing, leaving plastic spacer (5) in place. Install pot (6) in large hole in limit switch bracket (next to motor capacitor). Re-install nut and tighten.
7. Install pot gear on pot shaft and tighten setscrew (DO NOT OVERTIGHTEN).
8. Rotate pot to mid position.
9. Mesh drive and driven gears (do not rotate pot during this step). Align top surfaces of gears to prevent setscrew interference during rotation. Tighten drive gear setscrew (DO NOT OVERTIGHTEN).
10. **EL-55:** Press circuit board onto spacers so spacers lock into holes. **EL-100 to 1600:** Install circuit board with spacers/screws/flat washers/star washers provided.
11. Re-install motor capacitor if it was removed for access.

1. Connect positioner board terminals 37 and 40 (brown leads) to terminals 11 and 12 on the left side of the actuator's main terminal strip. To do this, remove the heater leads from terminals 11 & 12 and cut off the pin terminals. Using new pin terminals (blue) from the kit, install one heater wire and one positioner wire into each pin terminal and crimp them in place. Replace the pin terminals into the main terminal strip. Observe correct terminal numbering (heater leads may be connected either way).
- 2a. First: remove links from 2-10 and 3-7.
2. Connect remaining positioner leads to the main actuator terminal strip on the right side as follows: 41 to 4, 42 to 2, 43 to 3, 45 to 5, 45 to 8 (there are two terminal 45's), 50 to 7, 51 to 10.
3. Use wire ties to harness leads into neat groups and away from heater and torque switches.
4. Select line voltage with selector switch on positioner board.

## Wiring:

Before beginning wiring connections, remove yellow and blue jumper wires from right side of main terminal strip.

Refer to the wiring diagram (fig. 2) and connection diagram (fig. 3). For 3 phase and DC actuators, or actuators with Local Control, see further in this Installation and Operation manual. If your configuration is not included in the manual, contact EA before attempting to wire positioner.

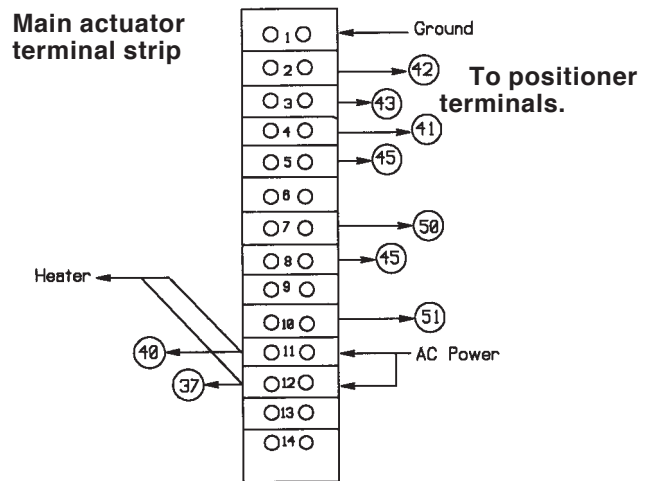


Fig. 3a. Actuator Main Terminal Strip.

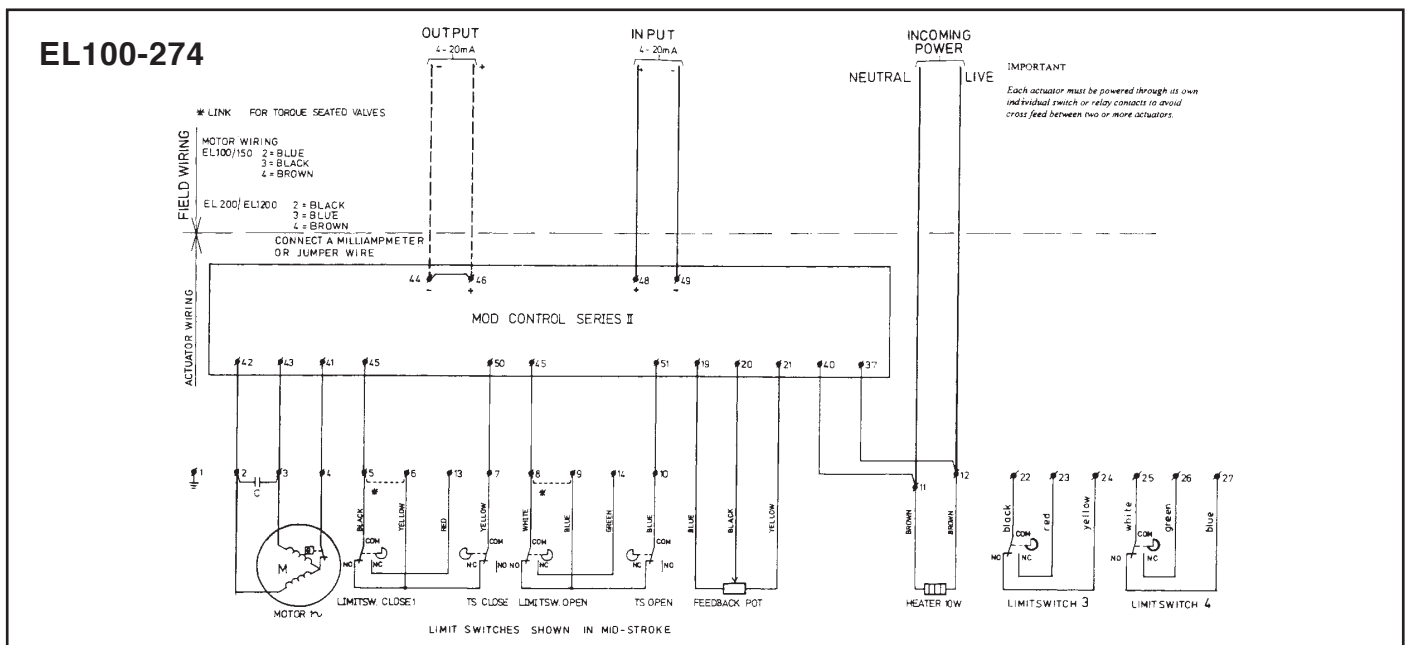


fig. 2. Positioner Wiring.

# Electronic Positioner - Installation and Calibration - MOD II

## Calibration:

### Before You Begin:

1. Actuator limit switches and mechanical stops must be properly set.
2. It is best to adjust the positioner with actuator mounted to the valve on which it is to be used. Since the closed position of the valve is generally more important (for shut-off) than the fully open position, you should provide a method for determining when the valve is closed.
3. Calibration pots are of the twenty turn type (end of rotation can be detected by listening for a click).
4. Re-install position indicator dial before beginning positioner adjustment, as it will provide a useful reference for motion and position during the adjustment process.
5. Pre-set DEADBAND pot to narrowest setting (fully ccw).

### Setting Procedure:

1. Connect a variable milliamp source (signal generator) to terminals 48(+) and 49(-).
2. Connect a milliammeter or jumper wire between terminals 44(-) and 46(+).
3. Apply power to actuator.

4. Set milliamp source to 4 mA. Actuator will run towards closed (cw) position (red LED will light while actuator runs). If reverse operation is desired (close on rising signal) see note 1 below.
5. Turn ZERO pot so that actuator moves toward fully closed position. Advance pot slowly so as not to overshoot the limit switch. The 4 mA point should correspond with the point at which the limit switch just clicks.

**Note: The actuator will not run past the limit switches. If valve travel is inadequate, re-adjust the limit switches.**

6. Set milliamp source to 20 mA. Actuator will run towards open (ccw) position. Green LED will light while actuator runs.
7. Turn SPAN pot in the same manner as in step 4 for fully open valve position.
8. Repeat steps 4 through 7 until both open and closed positions are satisfactory.
9. Set milliamp source to 12 ma.
10. Adjust "ALIGNMENT" pot so that actuator moves to 45° (for a 90° actuator). Your ammeter, if connected to the output terminals, will indicate approximately 12 mA. Adjust this setting until 12 mA is indicated.
11. Re-check ZERO and SPAN for output indication. Steps 4 through 10 may be repeated to obtain the highest degree of accuracy, however output indication cannot be set independently of position. Accuracy of output is +/- 0.15 mA of command signal (i.e., for a command signal of 4.00 mA, an output indication of 3.85 to 4.15 mA or better should be attainable).

### Notes:

1. For "reverse acting" (i.e., 20 mA to close) reverse pot leads on terminals 19 and 21, motor leads on terminals 42 and 43, and limit switch leads on terminals 50 and 51.
2. The positioner board, as supplied, is configured for "fail in place" on loss of control signal. This may be changed to "fail closed" by removing configuring plugs (next to terminal 46) from pins 2 and 3 and replacing them on pins 1 and 4.
3. Deadband and slow-approach: You will observe, during positioner adjustment, that as the actuator nears the set point, the appropriate LED will pulse several times before the actuator stops. If the pulsing seems prolonged or excessive, increase the dead-band (rotate cw). Note that this will affect the zero and span settings so these points should be re-adjusted if the deadband is widened after they have been initially set.
4. All signal wires are to be free of electrical noise and interference. It is recommended that all signal wires be shielded or run in separate grounded metal conduit.
5. Actuator must be properly grounded for MOD to operate correctly.

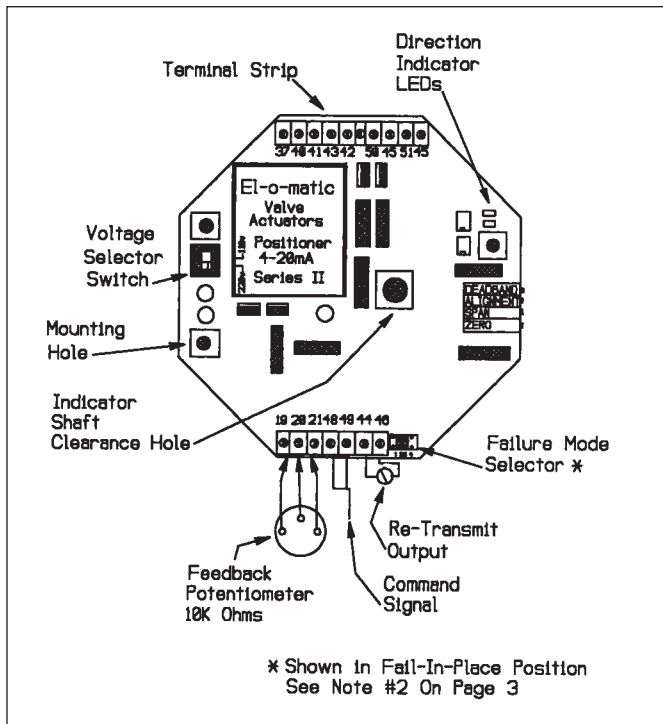


fig. 3b. Positioner Board Layout.

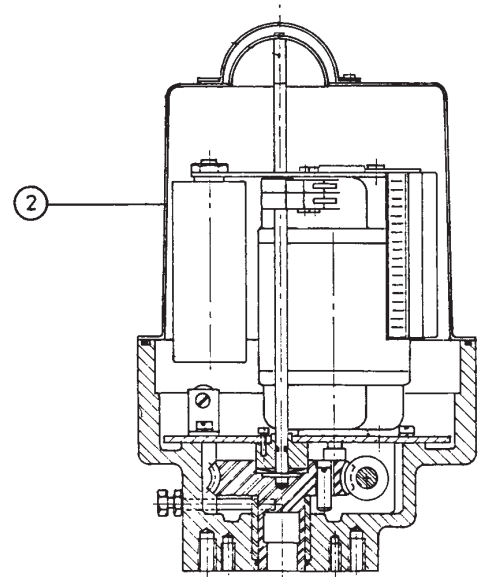
# Plug and socket - Installation Instructions

- PL

The plug and socket assembly is fixed to the actuator housing on one of the two ancillary mounting pads. The small pad is for the 6 pole socket and the large pad is for the 16 pole version.

**Before starting check "PL" kit to ensure that all parts are available.**

Pc.Nr.	Qty	Description
1	1	Rubber gasket, 6 pole.
2	4	Screw and lock washer.
3	1	Socket connector, 6 pole.
4	1	Plug connector, 6 pole.
5	1	Rubber gasket, 16 pole.
6	1	Socket connector, 16 pole.
7	1	Plug connector, 16 pole.



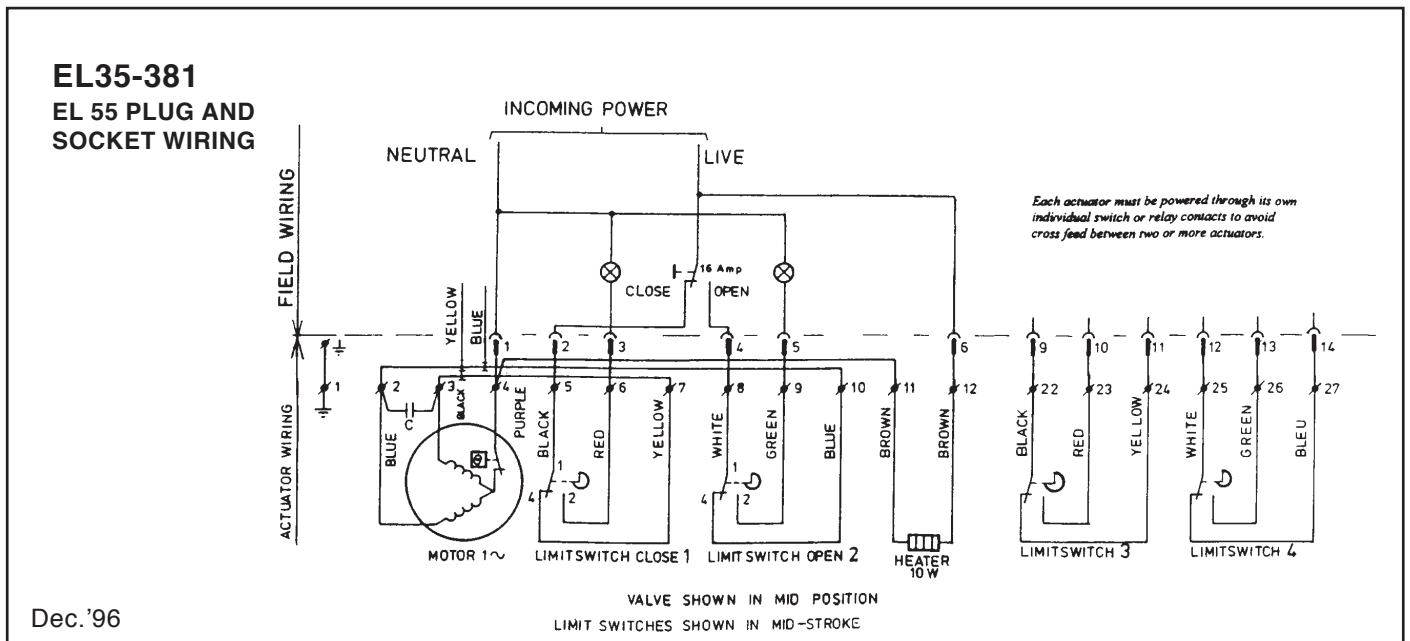
**Fig. 1.**  
**General Arrangement**

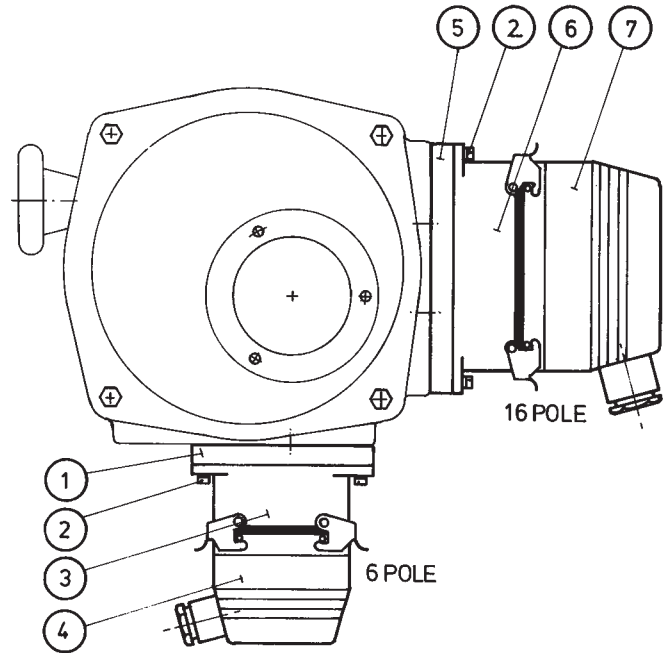
## Installation Procedure

1. Remove actuator cover (2).
2. Remove one blindplug from actuator conduit entry.
3. Bolt connector socket (male pins) (3) to actuator housing after feeding 7 electrical leads through actuator conduit entry into motor compartment.
4. Ensure that rubber gasket (1) is placed between Connector Socket and actuator housing.

5. Connect wiring from connector socket to actuator terminal strip as follows:-

From Socket Connector	Term. No.	
	EL-55	EL-100/2500.
Yellow/Green	- 1	1
Purple	- 4	4
Black	- 5	5
Red	- 6	13
White	- 8	8
Green	- 9	14
Brown	- 12	12





**Fig. 2.**  
**Plug and Socket Layout**

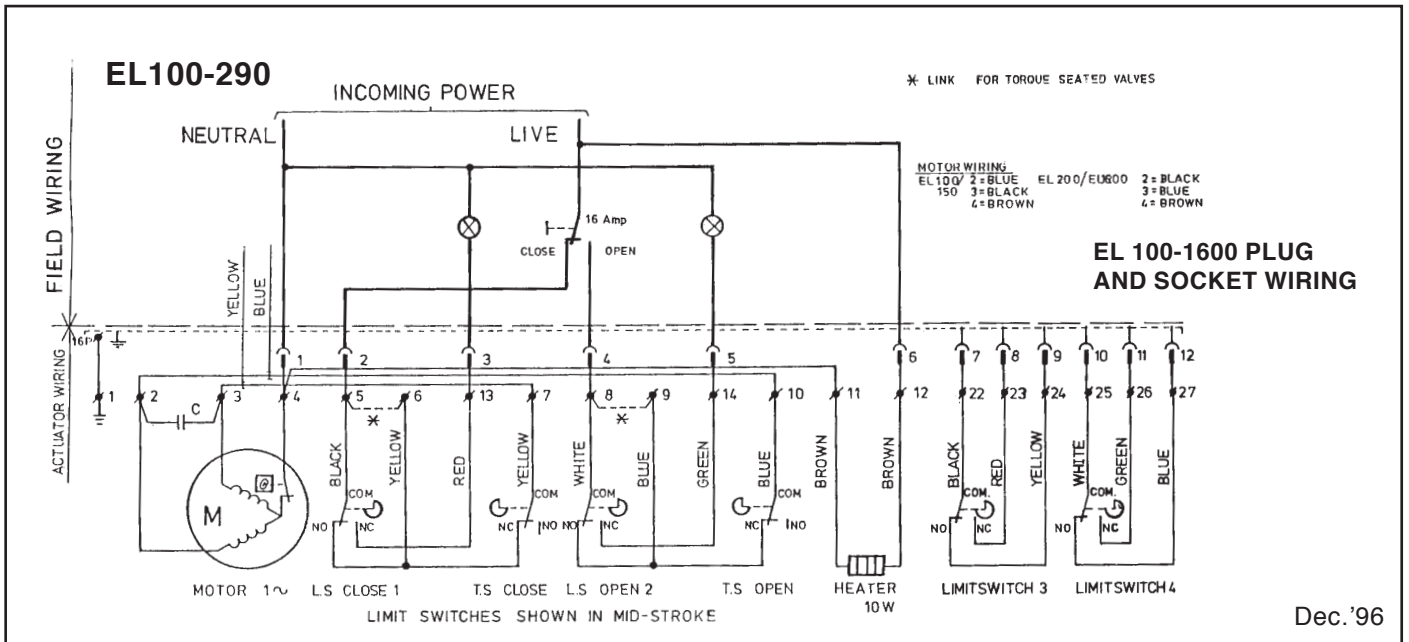
6. Replace actuator cover and fasten bolts securely taking care that the "O" ring is properly located in the "O" ring groove.
7. Connect connector plug (female pins) as follows:-

Cable.	Plug connector terminal. No.
Earth	- Plug chassis.
Neutral	- 1
Close command	- 2
Close signal	- 3
Open command	- 4
Open signal	- 5
Heater Phase	- 6

Please note:

The above is the method of wiring for the 6 pole plug and socket. Should you require to connect more cores to your unit we suggest that you use a 16 pole plug and socket connector. The wiring diagram for this will be available through EA.

The wiring shown here is for a single phase supply. If you are working with a different supply please be sure to obtain a proper diagram.

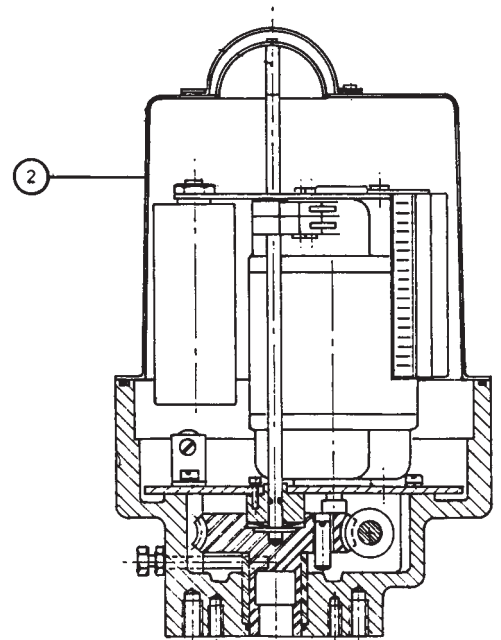


Dec.'96

The local controller assembly is fixed to the actuator housing located on the smaller of the two ancillary mounting pads.

**Before starting check "LC" kit to ensure that all parts are available.**

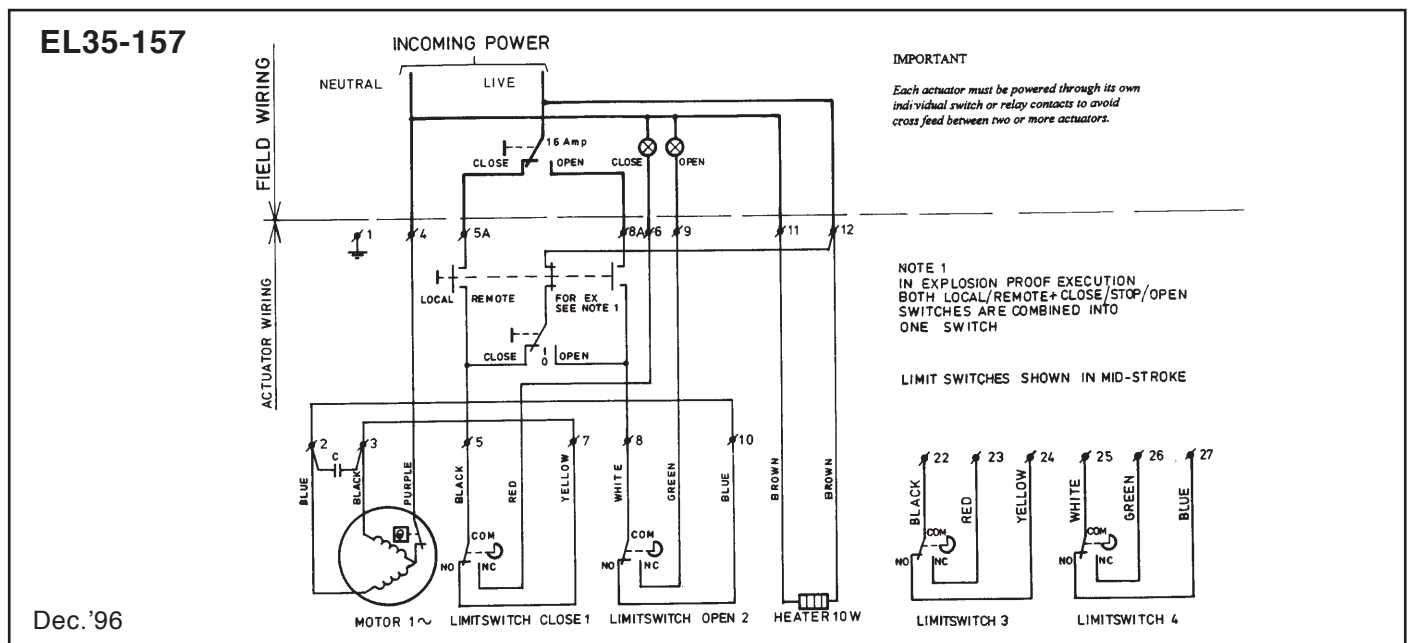
Pc.Nr.	Qty	Description
1	1	Rubber gasket.
2	4	Screw and lock washer.
3	1	Local control station.

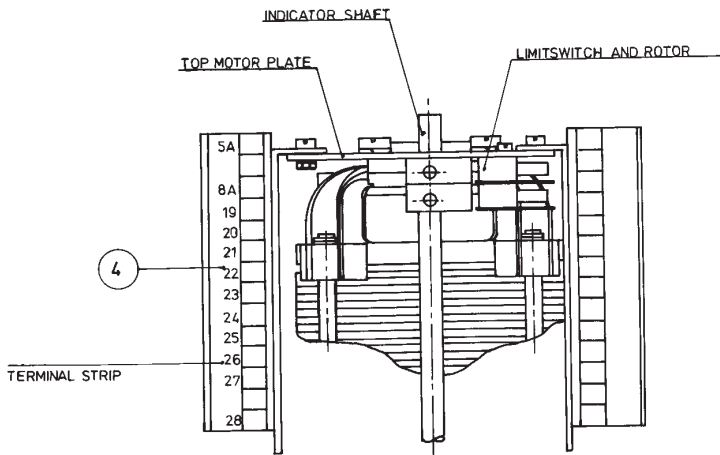


**Fig. 1.**  
**General Arrangement**

### Installation Procedure

1. Remove actuator cover (2).
2. Bolt Local Control Station to actuator housing after feeding the Five electrical leads through the conduit entry into the motor compartment.
3. Ensure that rubber gasket (1) is placed between Local Control Station and actuator housing.
4. Remove one blind plug from actuator conduit entry (always mount the Local Control Station on the face with one conduit entry, leaving both the other entries available for cabling).



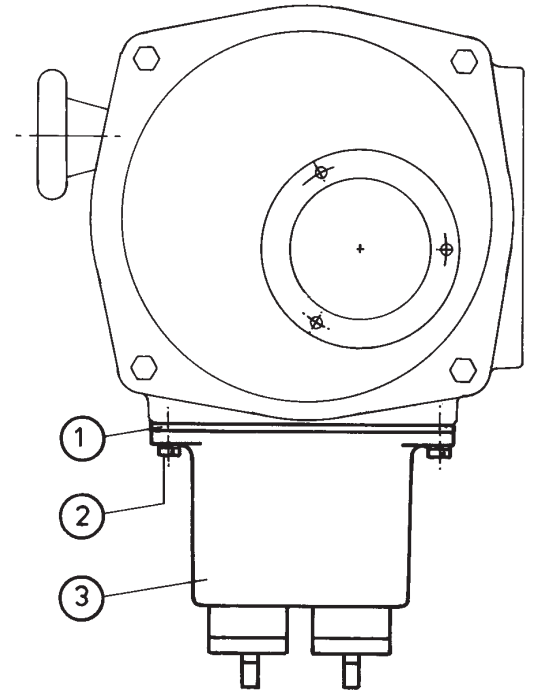


**Fig. 2.**  
**Location of Terminal Strip**

5. Connect wiring from Local Control Station to terminal strips as follows:-

Cable from Control Station	Term No.
Black 5A	5A (aux. term. strip)
Black 5	5 (main term. strip)
Brown 12	12 (main term. strip)
White 8A	8A (aux. term. strip)
White 8	8 (main term. strip)

6. Replace actuator cover and fasten bolts securely taking care that the "O" ring is properly located in the "O" ring groove.

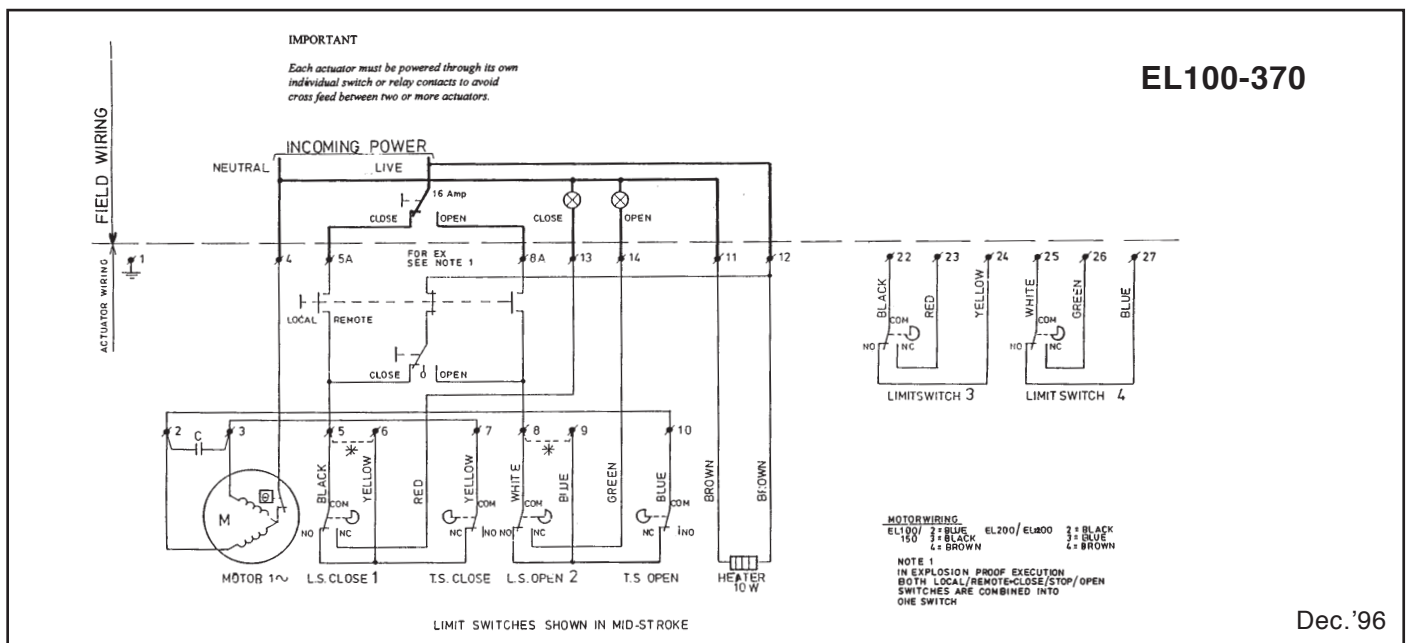


**Fig. 3.**  
**Local Controller Layout.**

Please note:

The above procedure may be used for either the standard LC, or the alternative version with the key lock.

The wiring shown here is for a single phase supply. If you are working with a different supply, or MOD option, please be sure to obtain a proper diagram.



# Disassembly procedure

---

## Caution:

- Do not attempt to work on your actuator until all power to the unit has been shut off.
- Always disconnect all incoming power leads from the actuator terminal strips.
- Never disassemble or reset torqueswitches
- For bracket drawing reference numbers refer to the applicable parts drawing.

## EL-20.

1. Remove cover (6).
2. Remove motor support plate (11) by removing five screws (25).
3. Lift motor support plate, motor and switch assembly from the unit housing, taking care not to bend the indicator shaft. The indicator shaft comes out, it must be removed with the motor support plate.
4. Remove setscrew (41) and pins (37) and slide the wormshaft (34) from the unit housing.
5. All gearing can now be removed from the housing.

## EL-35/55.

1. Remove cover (3).
2. Remove the indicator dial (26).
3. Remove motor support plate (15) by removing seven screws (16).
4. Fix indicatorshaft (with cams) to prevent sliding down.
5. Lift motor support plate, motor and switch assembly from the unit housing, taking care not to bend the indicator shaft. The indicator shaft comes out, it must be removed with the motor support plate.
6. Remove setscrew (45), pins (39) and (42) and draw the wormshaft from the unit housing by pulling handwheel (56).
7. All gearing can now be removed from the housing.

## EL-100/150.

1. Remove cover (38).
2. Remove motor support plate (4) by removing seven screws (5).
3. Important: Be sure that unit is not torqued against the stop screws. If it is, relieve by turning hand wheel
4. Fix indicatorshaft (with cams) to prevent sliding down.
5. Lift motor support plate, motor and switch assembly from the unit housing, taking care not to bend the indicator shaft. The indicator shaft comes out, it must be removed with the motor support plate.
6. Remove four screws (71) and remove wormcap (73).
7. Slide thrust bearing (65) and torque springs (70) from the worm shaft (72). The worm (68) and four torque springs (70) can now be removed from the wormshaft.
8. Remove key (69) and retaining ring (67).
9. Slide worm gear (66) over worm shaft and remove key and remove wormshaft (72) by pulling handwheel (56).

## EL-200/350.

1. Remove cover (36).
2. Remove motor support plate (4) by removing six screws.

3. Important: Be sure that unit is not torqued against the stop screws. If it is, relieve by turning hand wheel
4. Fix indicatorshaft (with cams) to prevent sliding down.
5. Lift motor support plate, motor and switch assembly from the unit housing, taking care not to bend the indicator shaft. The indicator shaft comes out, it must be removed with the motor support plate.
6. Remove spur gear (81), worm (84), Wormshaft (85) and two thrust bearings (86) by lifting spur gear (81) upwards out of the gear case.
7. Remove four screws (99) and remove wormcap (72).
8. Slide thrust bearing (63) and eight torque springs (67) from the wormshaft (69).
9. Slide worm gear (64) and eight torque springs from the wormshaft.
10. Remove Key (66) and (71) and screws (65) and draw the wormshaft (69) from the unit by pulling handwheel (54).

## EL-500/800.

1. Remove cover (77).
2. Remove motor support plate (61) by removing 7 screws (62).
3. Important: Be sure that unit is not torqued against the stop screws. If it is, relieve by turning hand wheel.
4. Fix indicatorshaft (with cams) to prevent sliding down.
5. Lift motor support plate, motor and switch assembly from the unit housing, taking care not to bend the indicator shaft. The indicator shaft comes out, it must be removed with the motor support plate.
6. Remove spur gear (13), worm (11), Wormshaft (21) and two thrust bearings (10) by lifting spur gear (13) upwards out of the gear case.
7. Remove four screws (34) and remove wormcap (31).
8. Slide thrust bearing (24) and torque springs (27) from the wormshaft (96).
9. Remove key (29) and screw (104) and slide worm gear (26) and eight torque springs from the wormshaft.
10. Remove key (26) and (29) and screw (104) and draw the wormshaft (96) from the unit by pulling handwheel (3).

## REASSEMBLY

Assembly in reverse order of above

---

## Trouble Shooting

Although we would not expect you to experience any problems with your valve actuator we have listed some checkpoints should your actuator not function as desired.

### Rotation

If limit switch fails to stop valve travel, check the following:

- Direction of rotation of output shaft
- Control wiring
- Limit switch setting

Actuators with torque switches. If limit switch fails to stop valve travel:

- Check if link has been placed, for torque seated valve application. If not required - remove it.

### Motor Not Running

If unable to operate your motor:

- Check both motor power and control circuits for supply and continuity.
- Compare supply voltage with motor nameplate, if OK, then check motor amperage load.
- If stalled motor is indicated and torque switches have not tripped or valve is moveable by the hand wheel, consult your supplier.

### Overload

Excessive handwheel effort, motor overheating and/or high motor amperage load can indicate the following:

- Excessive valve load.
- Valve packing gland too tight.
- Improperly lubricated valve.
- Incorrect Motor capacitor.
- Ambient temperature too high.
- Valve cycling too often.
- Incorrect voltage.
- Incorrect wiring.

### Motor Stops

If torque switch trips before reaching end of valve travel:

- Incorrect setting of mechanical end stops.
- Obstacle in valve.
- Valve required torque higher than actuator rated torque.

### No Valve Movement - Motor Runs

- Drive sheared or not connected.

### No Valve Movement - Motor won't Run

- Valve plug/disk jammed or obstructed.
- Valve requires torque higher than actuator rated torque.
- Valve packing gland too tight.

### Stroking

It is not possible to stroke valve the full 90°:

- Check mechanical end stops.
- Check valve and actuator position.
- Actuator in open position = Valve in open position.

### Condensation

Moisture inside electrical compartment:

- Check if compartment heater has been connected.
- Check if compartment heater has been connected to the correct supply voltage.
- Check if compartment heater is continuously under power - not only when motor is energized.
- Check heater resistance:

120 V	-	1K $\Omega$
230 V	-	4700 $\Omega$
380-480 V	-	15K $\Omega$
24V	-	47 $\Omega$
- Check compartment cover seal.
- Check indicator window seal
- Check cable glands.
- Check pipe plugs in unused conduit entries.

# Wiring diagrams - Electric actuator

---

Following is a short list of wiring diagrams. If you need wiring for an actuator not listed please contact your nearest Elomatic facility or representative.

## Basic Actuators

Actuator model	Function			Drawing No.	Page
EL35/55	ON/OFF	1 Phase ~	Standard	EL35-101	36
EL35/55	ON/OFF	3 Phase ~	Standard	EL35-103	36
EL35/55	ON/OFF	DC	Current limiter	EL35-106	36
EL100/1600	ON/OFF	1 Phase ~	Standard	EL100-093 *	37
EL100/2500	ON/OFF	3 Phase ~	Standard	EL100-087	37
EL100/800	ON/OFF	DC	Standard	EL100-090	37
EL1200/2500	ON/OFF	1 Phase ~	Standard	EL2500-017 **	40

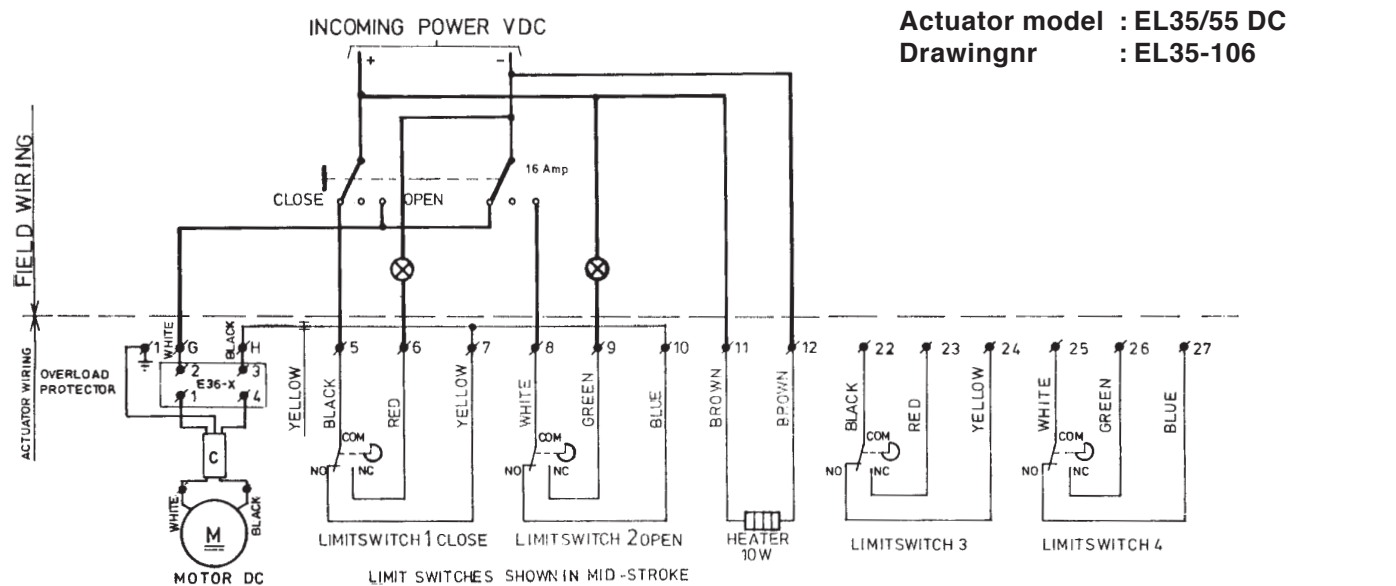
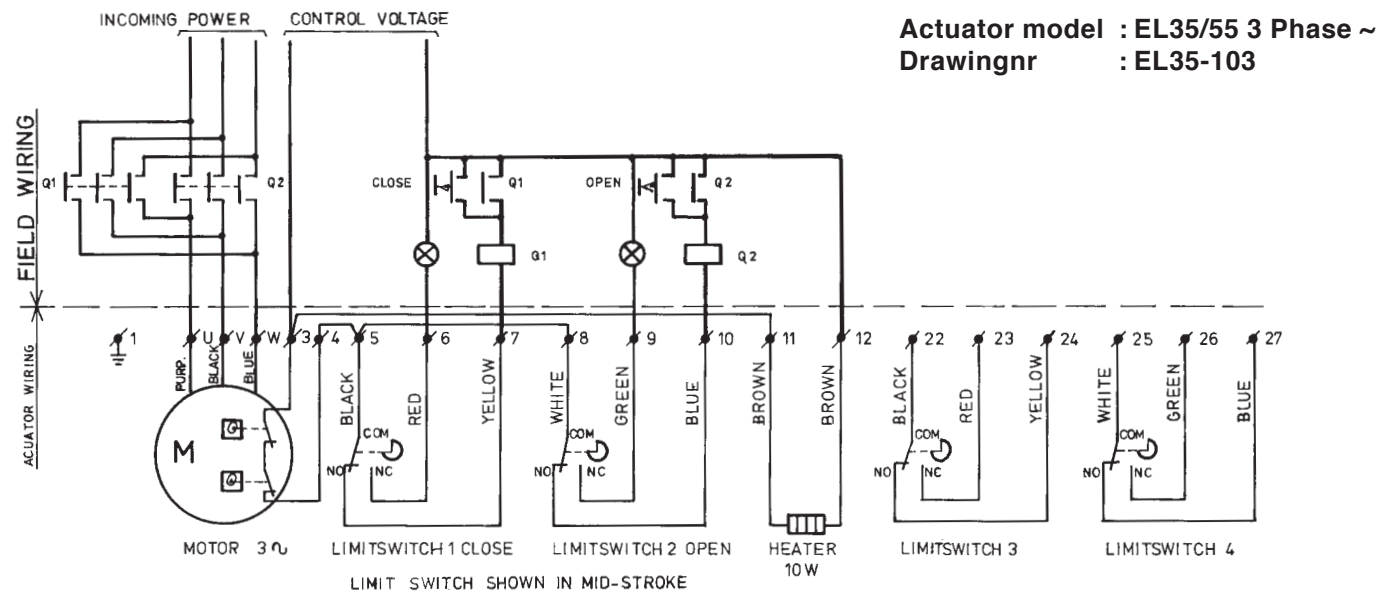
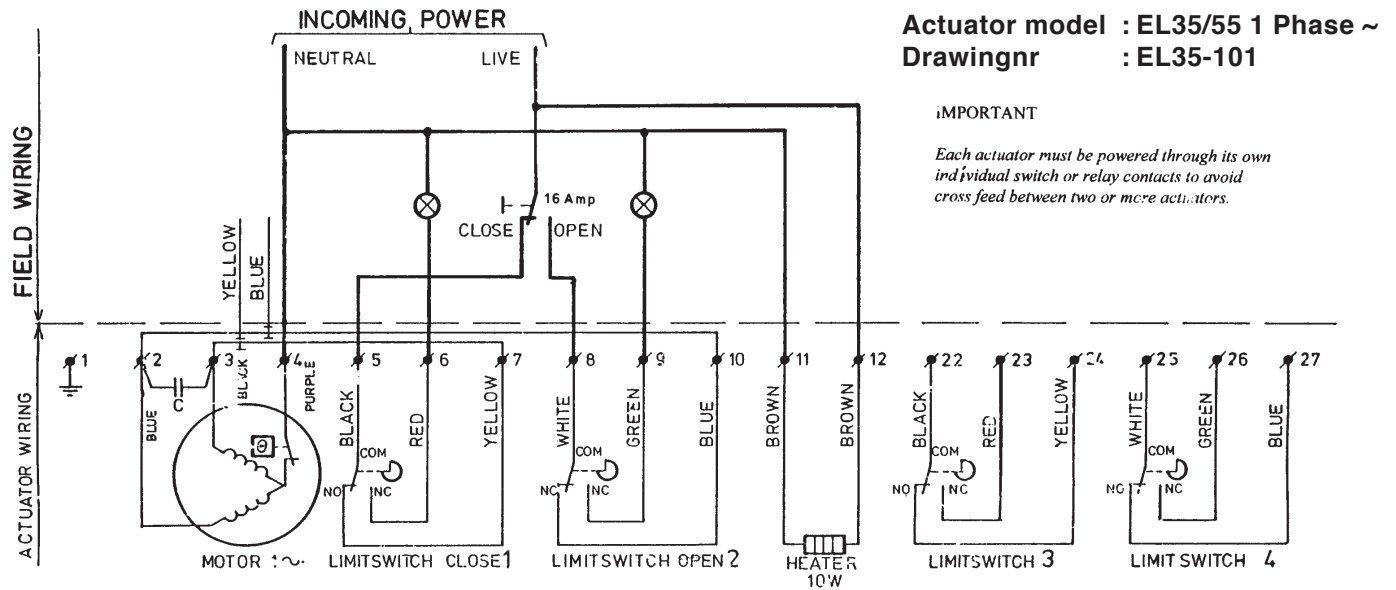
## Kit Options

Option	Actuator model	Function		Drawing No.	Page
Speed control	EL35/55	ON/OFF	1 Phase ~	EL35-239	38
Speed control	EL100/1600	ON/OFF	1 Phase ~	EL100-218 *	21
Potentiometer	EL35/55	ON/OFF	1 Phase ~	EL35-287	38
Potentiometer	EL100/1600	ON/OFF	1 Phase ~	EL100-114 *	20
Position transmitter 2 wire	EL35/55	ON/OFF	1 Phase ~	EL35-351	38
Position transmitter 2 wire	EL100/1600	ON/OFF	1 Phase ~	EL100-411	23
Position transmitter 4 wire	EL35/55	ON/OFF	1 Phase ~	EL35-337	39
Position transmitter 4 wire	EL100/1600	ON/OFF	1 Phase ~	EL100-390 *	25
Plug and socket	EL35/55	ON/OFF	1 Phase ~	EL35-381	29
Plug and socket	EL100/1600	ON/OFF	1 Phase ~	EL100-290 *	30
Local control station	EL35/55	ON/OFF	1 Phase ~	EL35-157	31
Local control station	EL100/1600	ON/OFF	1 Phase ~	EL100-370 *	22
Local control station	EL100/2500	ON/OFF	3 Phase ~	EL100-395	41
Integral contactors & local control station	EL100/2500	ON/OFF	3 Phase ~	EL100-268	41
3 Position control	EL35/55	ON/OFF	1 Phase ~	EL35-161	39
3 Position control	EL100/1600	ON/OFF	1 Phase ~	EL100-118 *	39
MOD Positioner	EL35/55	ON/OFF	1 Phase ~	EL35-288	40
MOD Positioner	EL100/1600	ON/OFF	1 Phase ~	EL100-274 *	27

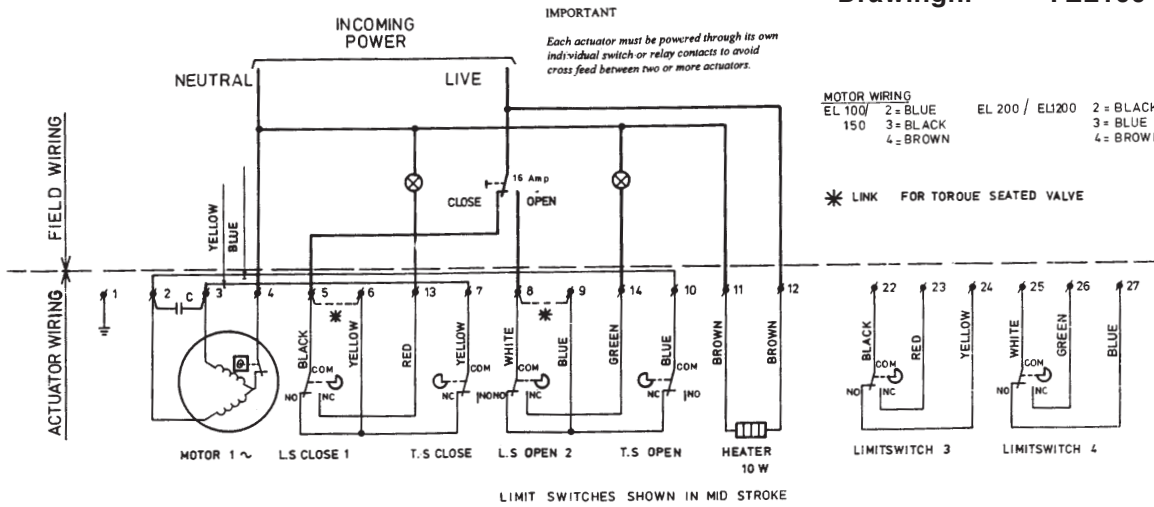
## Remark;

\* For EL1200/1600 only 220V

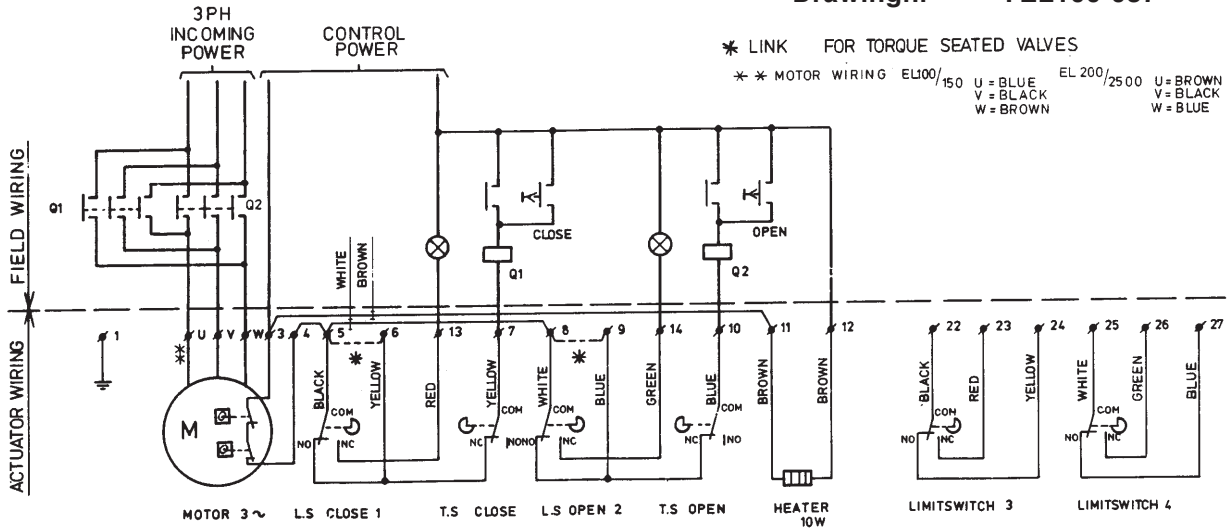
\*\* For EL1200/1600 only 120V



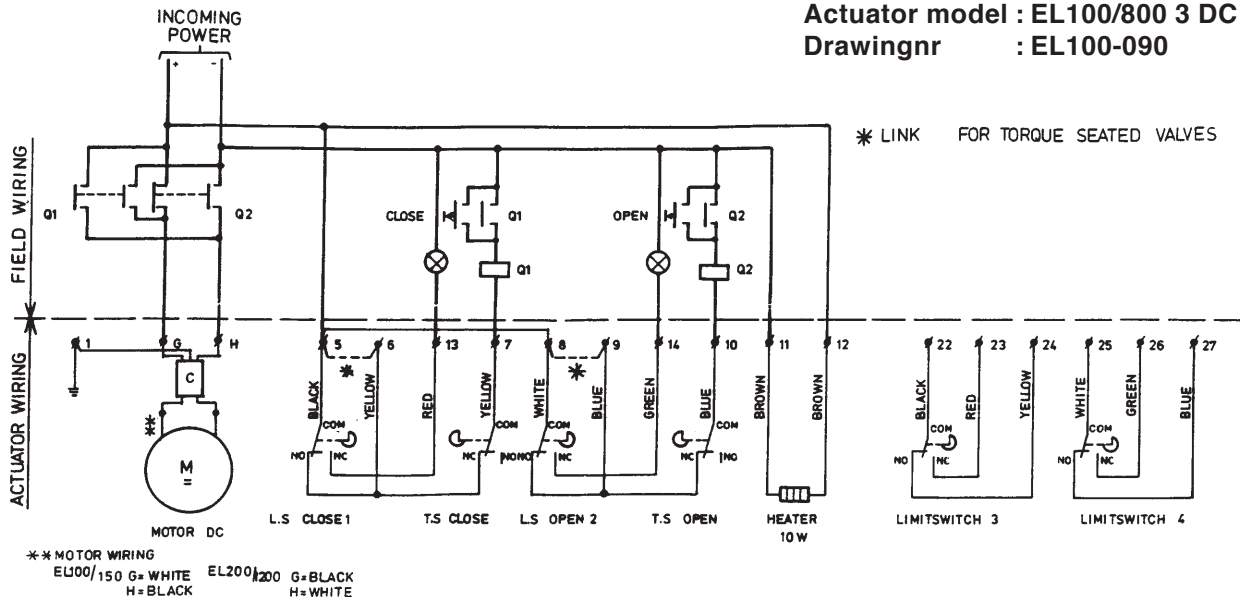
Actuator model : EL100/1200 1 Phase ~  
Drawingnr : EL100-093



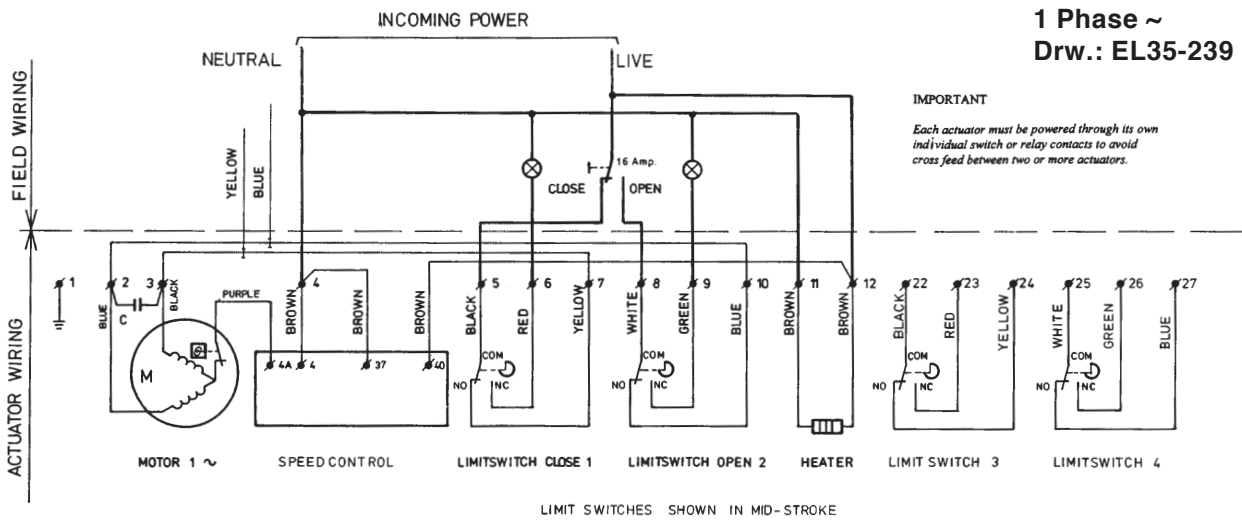
Actuator model : EL100/2500 3 Phase ~  
Drawingnr : EL100-087



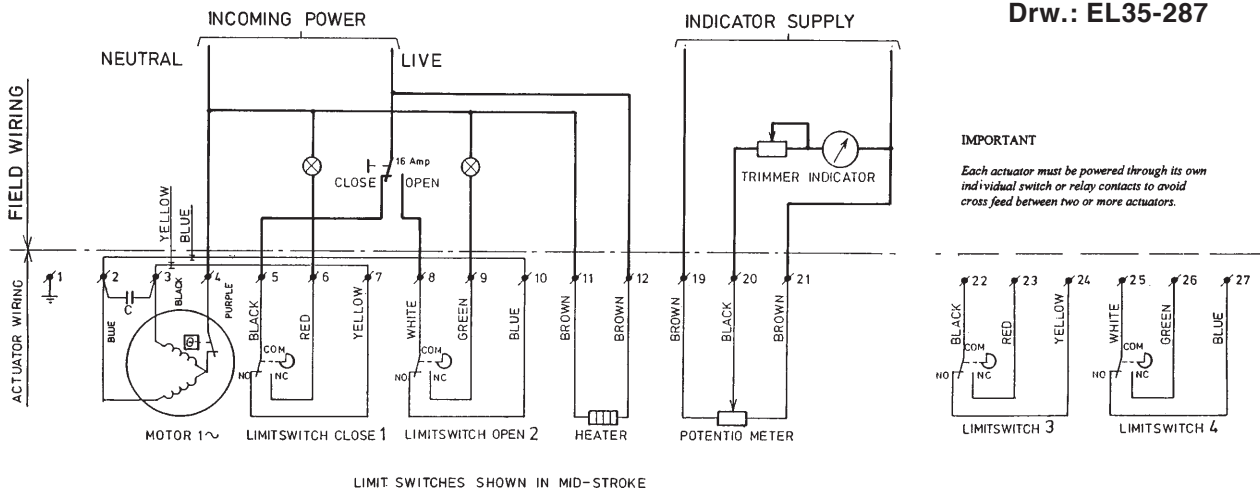
Actuator model : EL100/800 3 DC  
Drawingnr : EL100-090



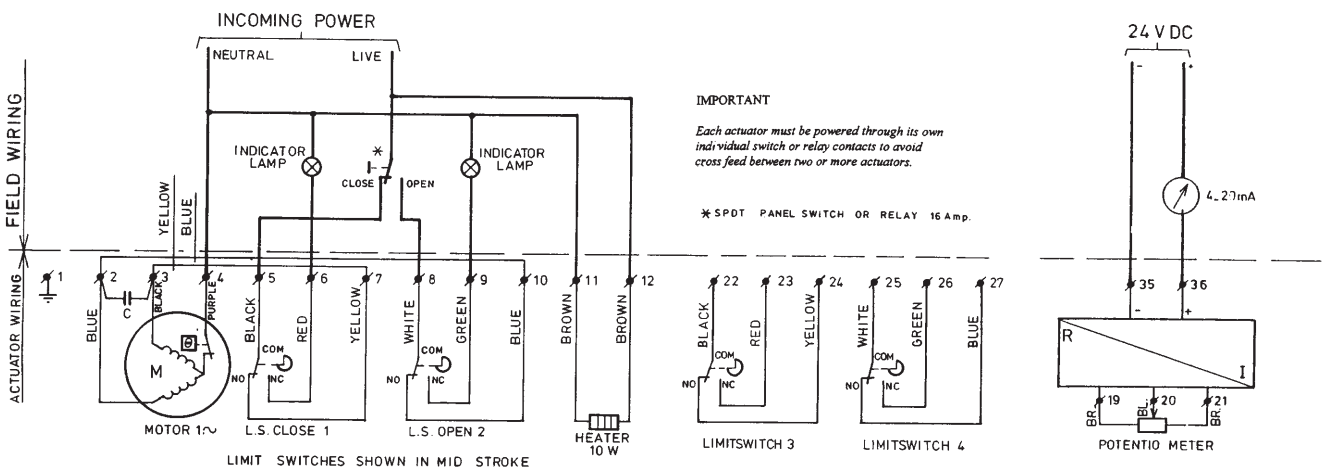
### SPEED CONTROL (SC) 1 Phase ~ Drw.: EL35-239



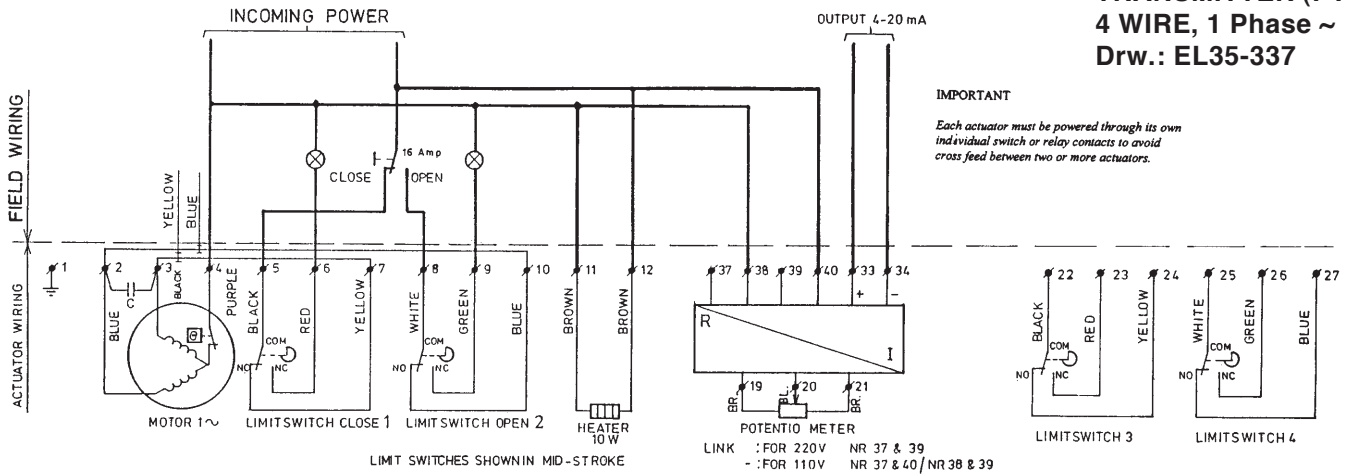
### POTENTIOMETER (POT) 1 Phase ~ Drw.: EL35-287



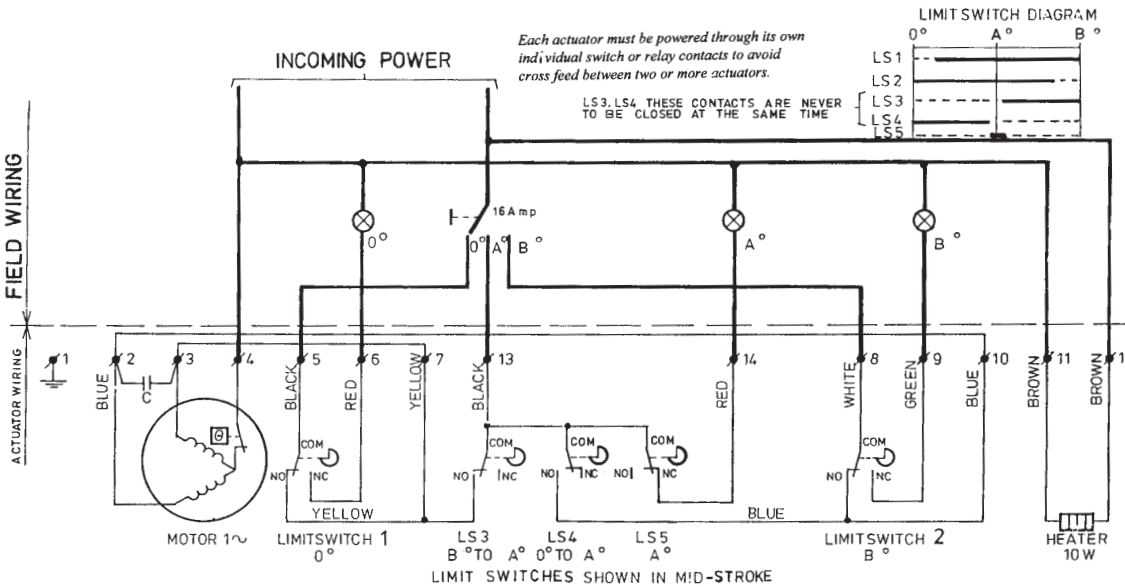
### POSITION TRANSMITTER (PT2) 2 WIRE, 1 Phase ~ Drw.: EL35-351



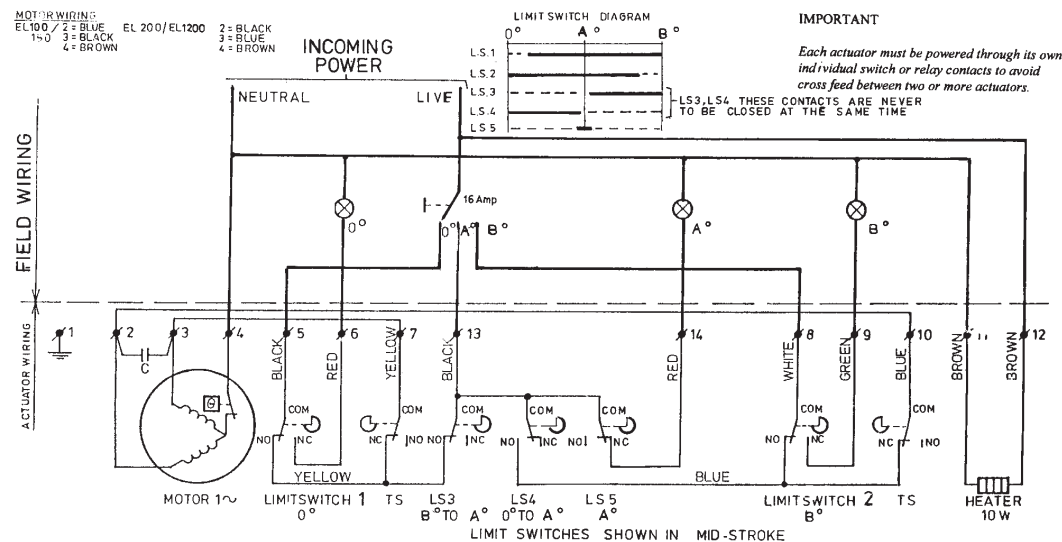
### POSITION TRANSMITTER (PT4) 4 WIRE, 1 Phase ~ Drw.: EL35-337



### 3 POSITION CONTROL (3 POS) 1 Phase ~ Drw.: EL35-161

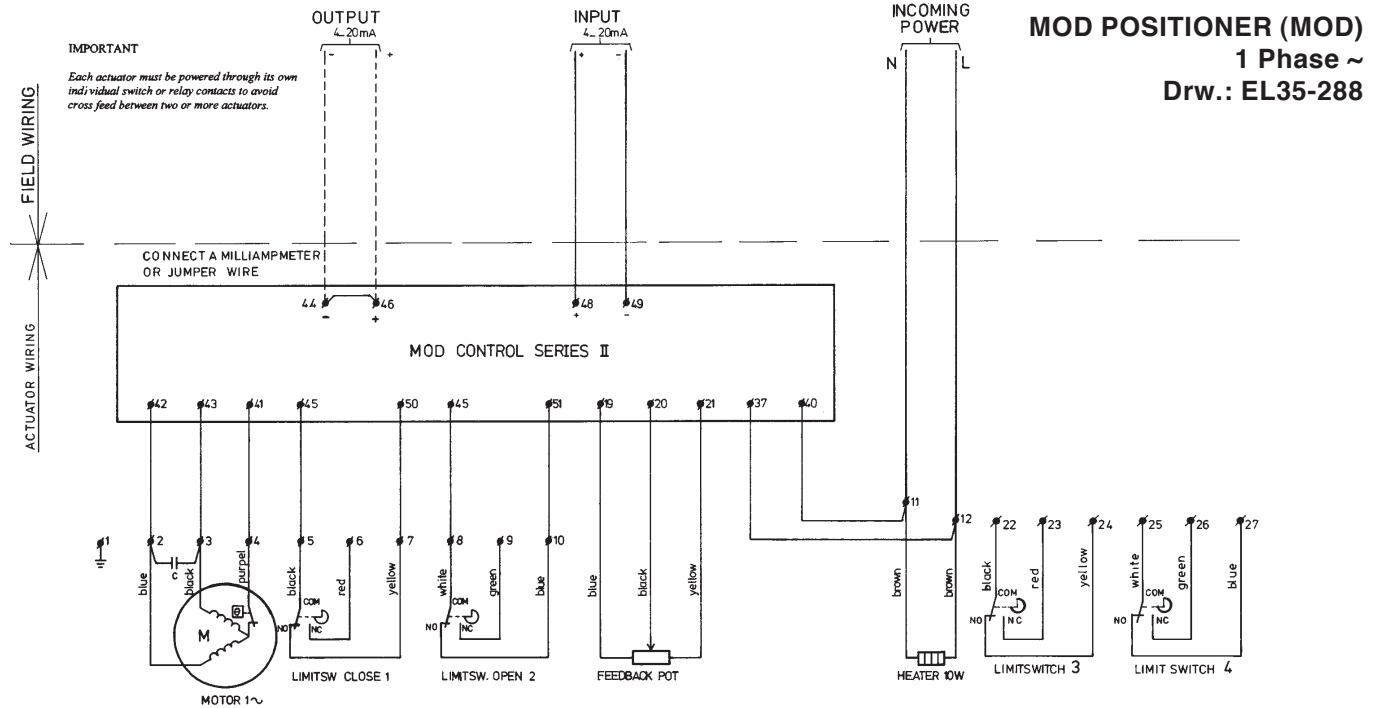


### 3 POSITION CONTROL (3 POS) 1 Phase ~ Drw.: EL100-118



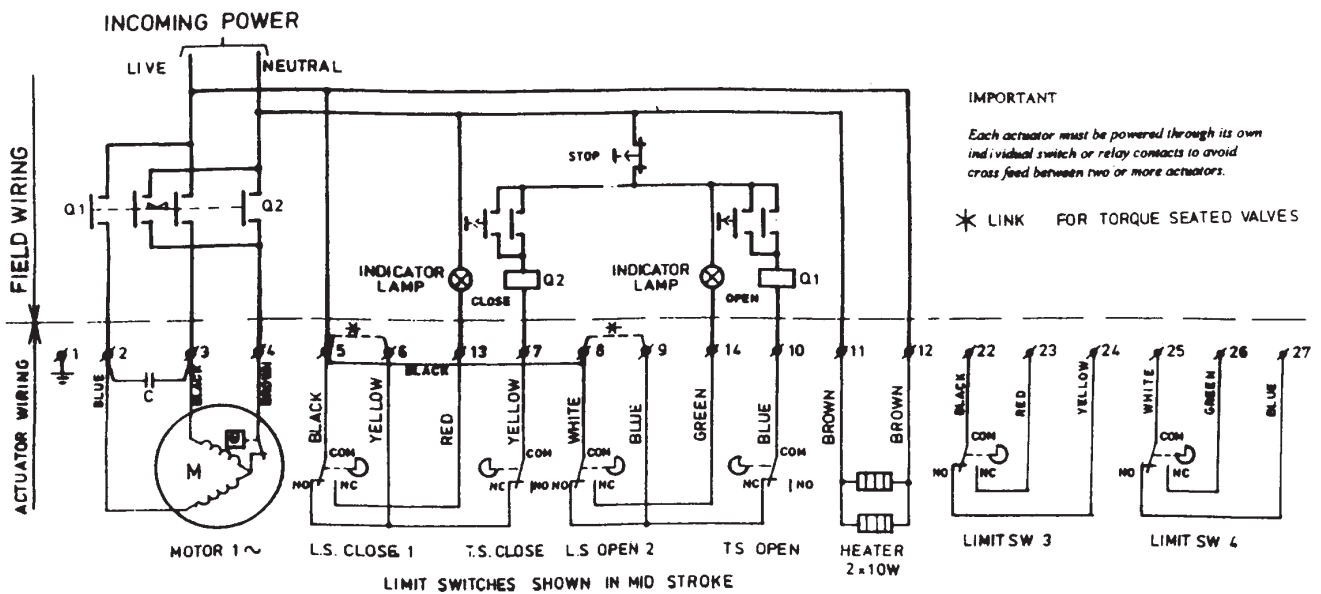
# Wiring Diagrams

KIT OPTIONS



## BASIC ACTUATORS

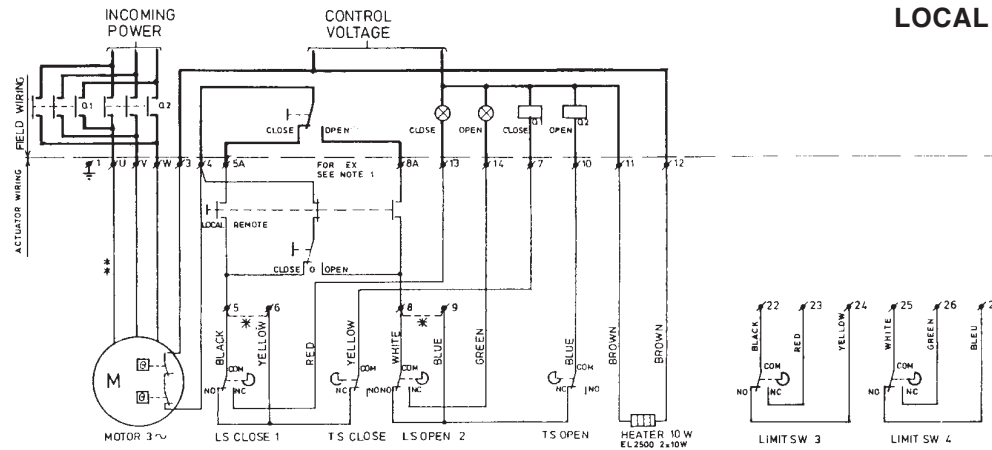
Actuator model : EL1200/2500 1 Phase ~  
Drawingnr : EL2500-017



# Wiring Diagrams

## KIT OPTIONS

### LOCAL CONTROL STATION (LC) 3 Phase ~ Drw.: EL100-395



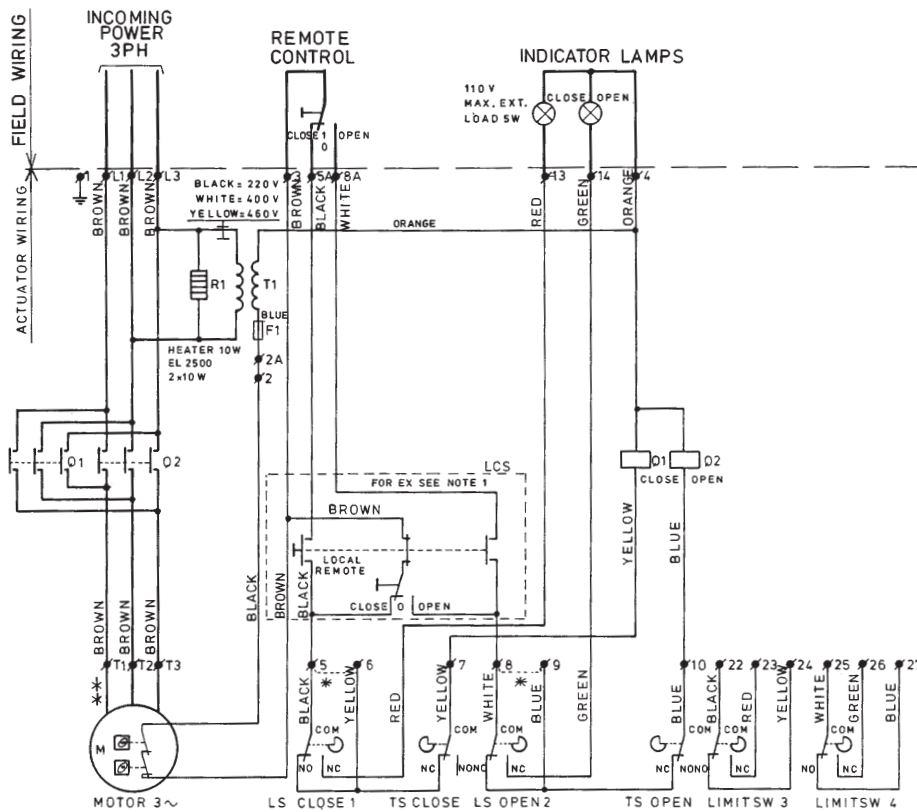
LIMIT SWITCHES SHOWN IN MID-STROKE

\* LINK FOR TORQUE SEATED VALVES

NOTE 1  
IN EXPLOSION PROOF EXECUTION  
BOTH LOCAL/REMOTE + CLOSE/STOP/OPEN  
SWITCHES ARE COMBINED INTO  
ONE SWITCH

\*\* MOTOR WIRING  
EL100/150 U=BLUE  
V=BLACK  
W=BROWN  
EL200/2500 U=BROWN  
V=BLACK  
W=BLUE

### INTEGRAL CONTACTORS & LOCAL CONTROL STATION 3 Phase ~ Drw.: EL100-268



NOTE 1  
IN EXPLOSION PROOF EXECUTION  
BOTH LOCAL/REMOTE + CLOSE/STOP/OPEN  
SWITCHES ARE COMBINED INTO  
ONE SWITCH

\* LINK FOR TORQUE SEATED VALVES

LIMIT SWITCHES SHOWN IN MID-STROKE

\*\* MOTOR WIRING

EL100/150 T1=BLUE  
T2=BLACK  
T3=BROWN  
EL200/2500 T1=BROWN  
T2=BLACK  
T3=BLUE